

DXA studio
27 E 4th Street
Feb. 11, 2026

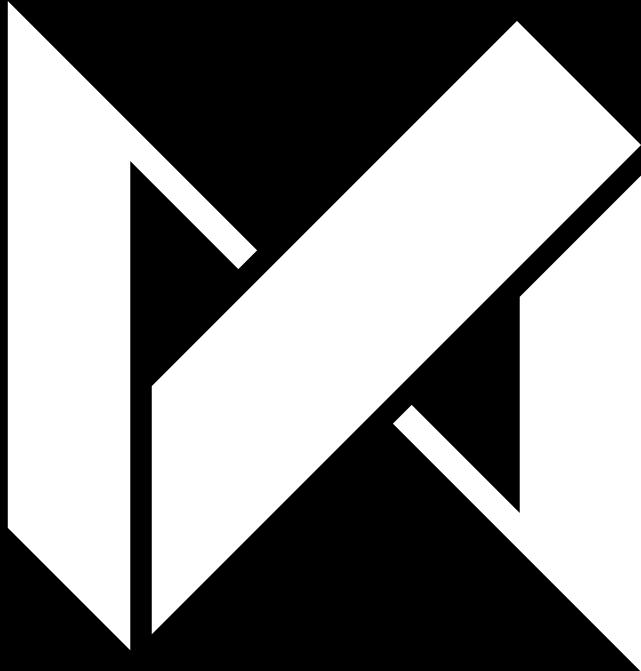

CONTENTS

- I. SITE ANALYSIS AND CONTEXT
- II. PROPOSED DESIGN
- III. STRUCTURAL DESIGN
- IV. APPENDIX



SITE ANALYSIS AND CONTEXT

27 EAST 4TH STREET NOHO HISTORIC DISTRICT EXTENSION

LANDMARKS PRESERVATION COMMISSION

DOCKET #: LPC-26-06702

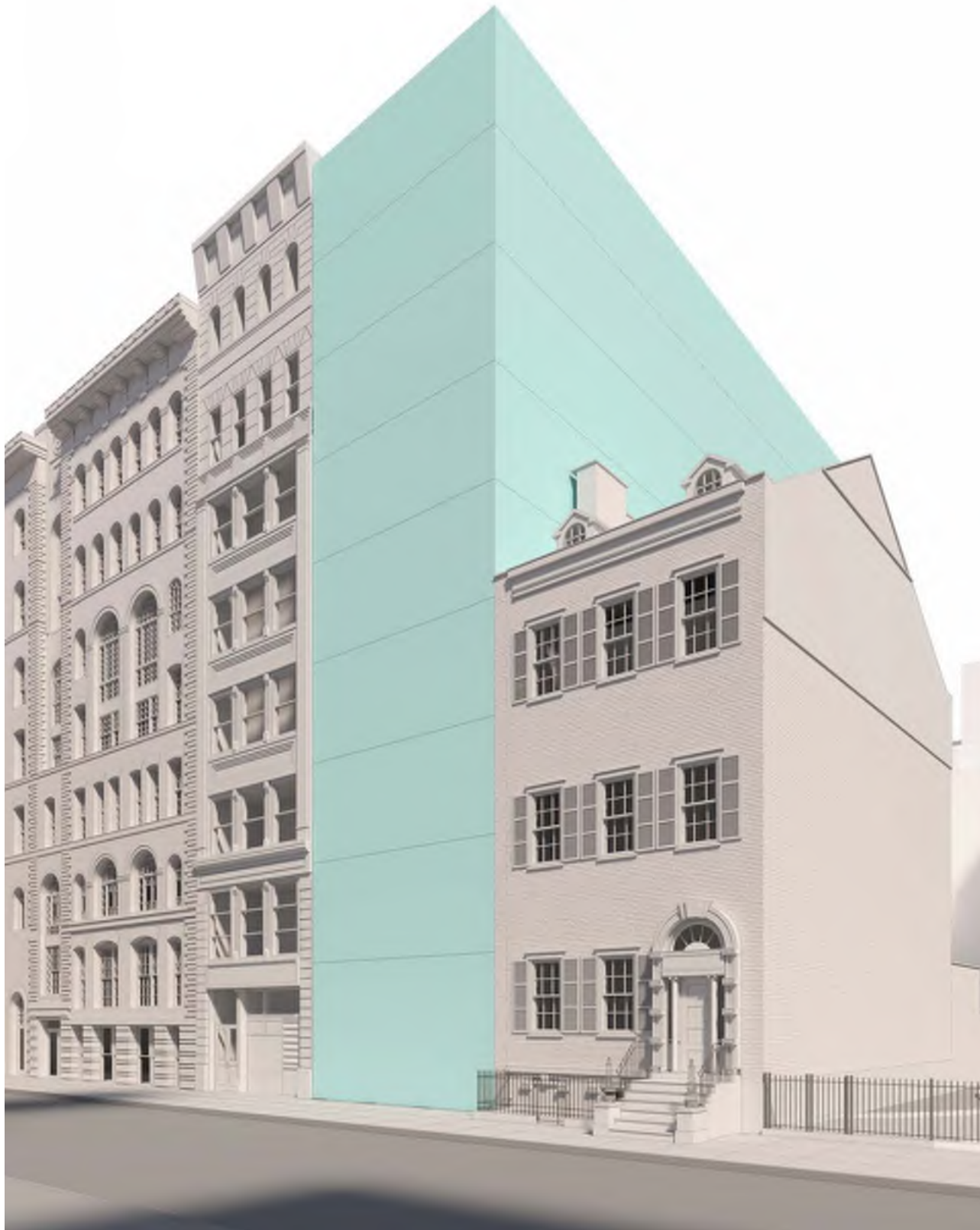

PROPOSED BUILDING

LEGEND

- 27 E. 4TH ST.
- MERCHANT'S HOUSE (INDIVIDUAL LANDMARK)

STABLE COURT
PRIVATELY OWNED
ALLEY

NOHO HISTORIC
DISTRICT

NOHO HISTORIC
DISTRICT EXTENSION

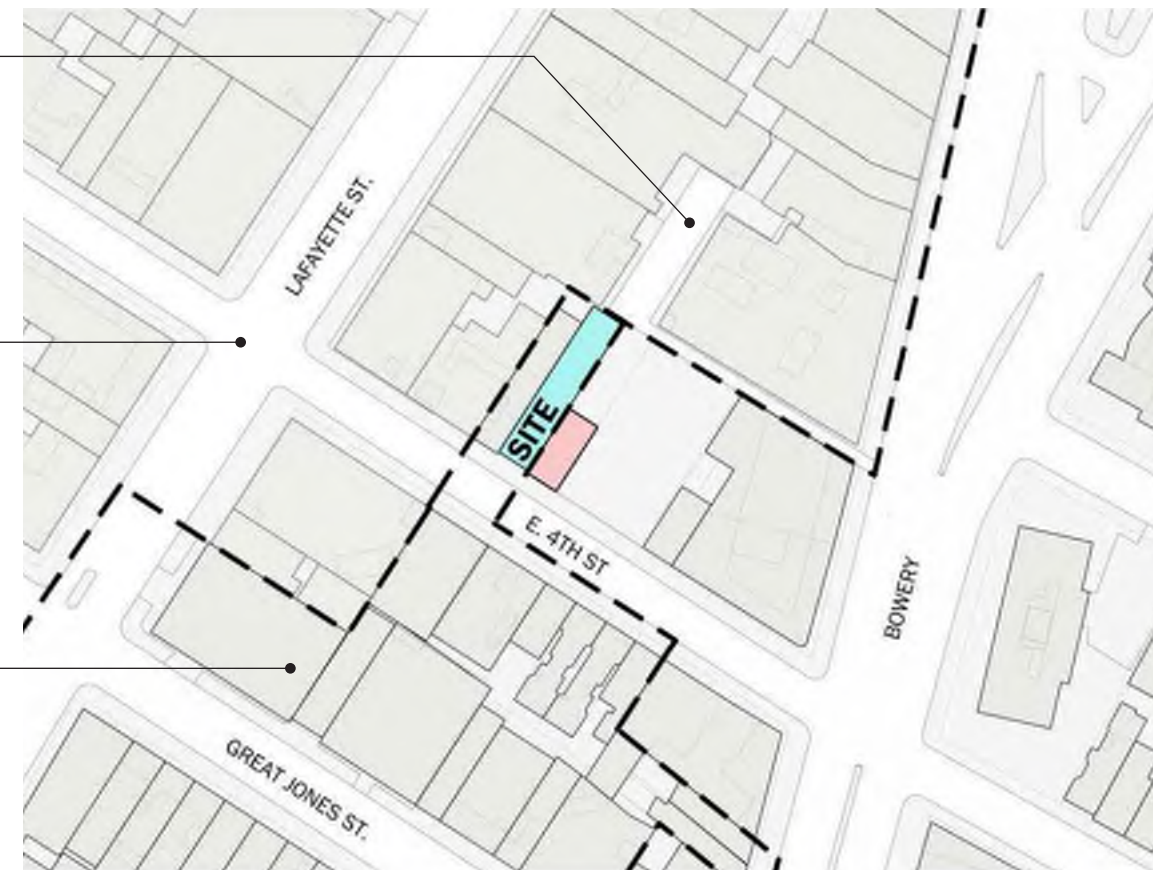

NOHO DISTRICT MAP

27 EAST 4TH STREET - OVERVIEW

SCALE N/A
CLIENT N/A
PROJECT NUMBER 25.29
DATE FEB 11, 2026



DXA studio
© DXA studio
dxastudio.com

894 6th Avenue
5th Floor
NYC 10001
T 212 874 0567



GILSANZ MURRAY STEFICEK
Structural Engineers and Building Envelope Consultants



Historic District Designation Map (NYC LPC)

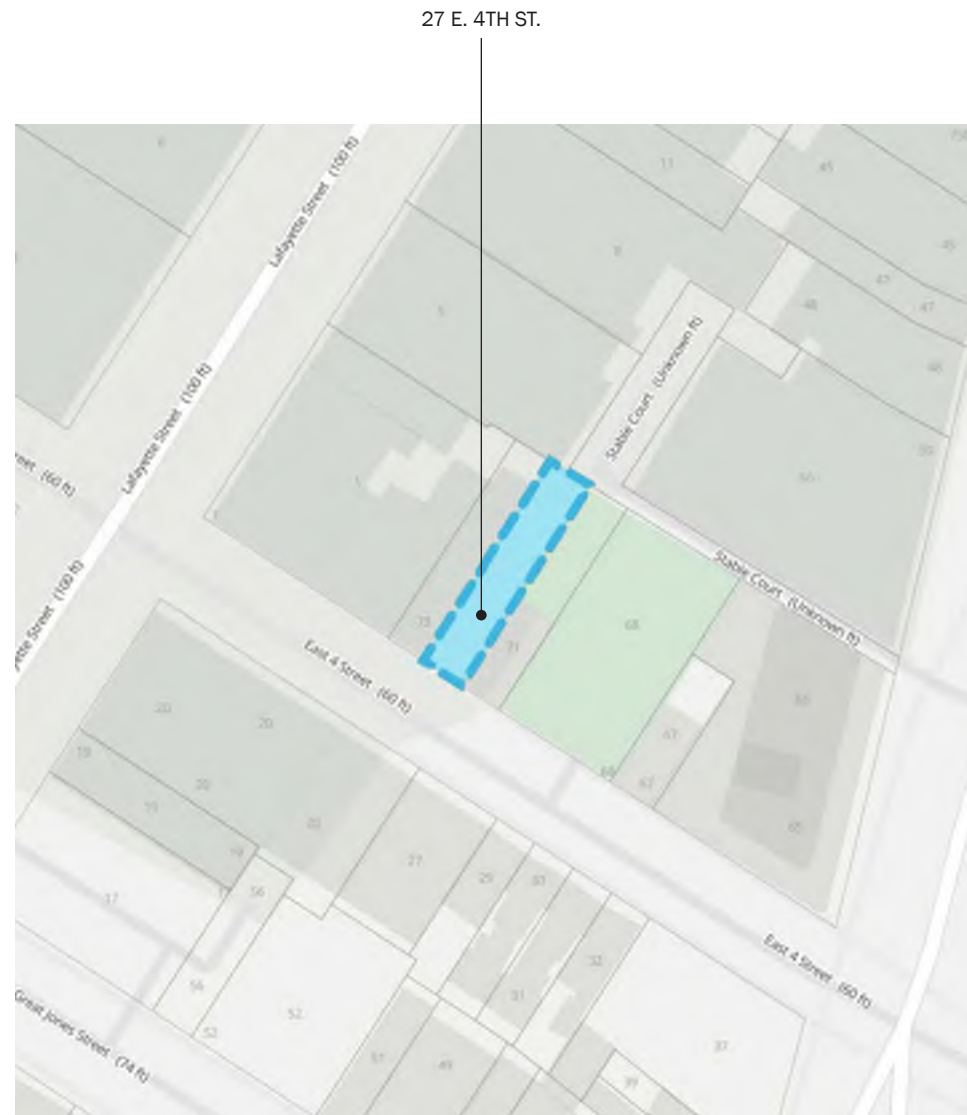

Block Map (via Zola)

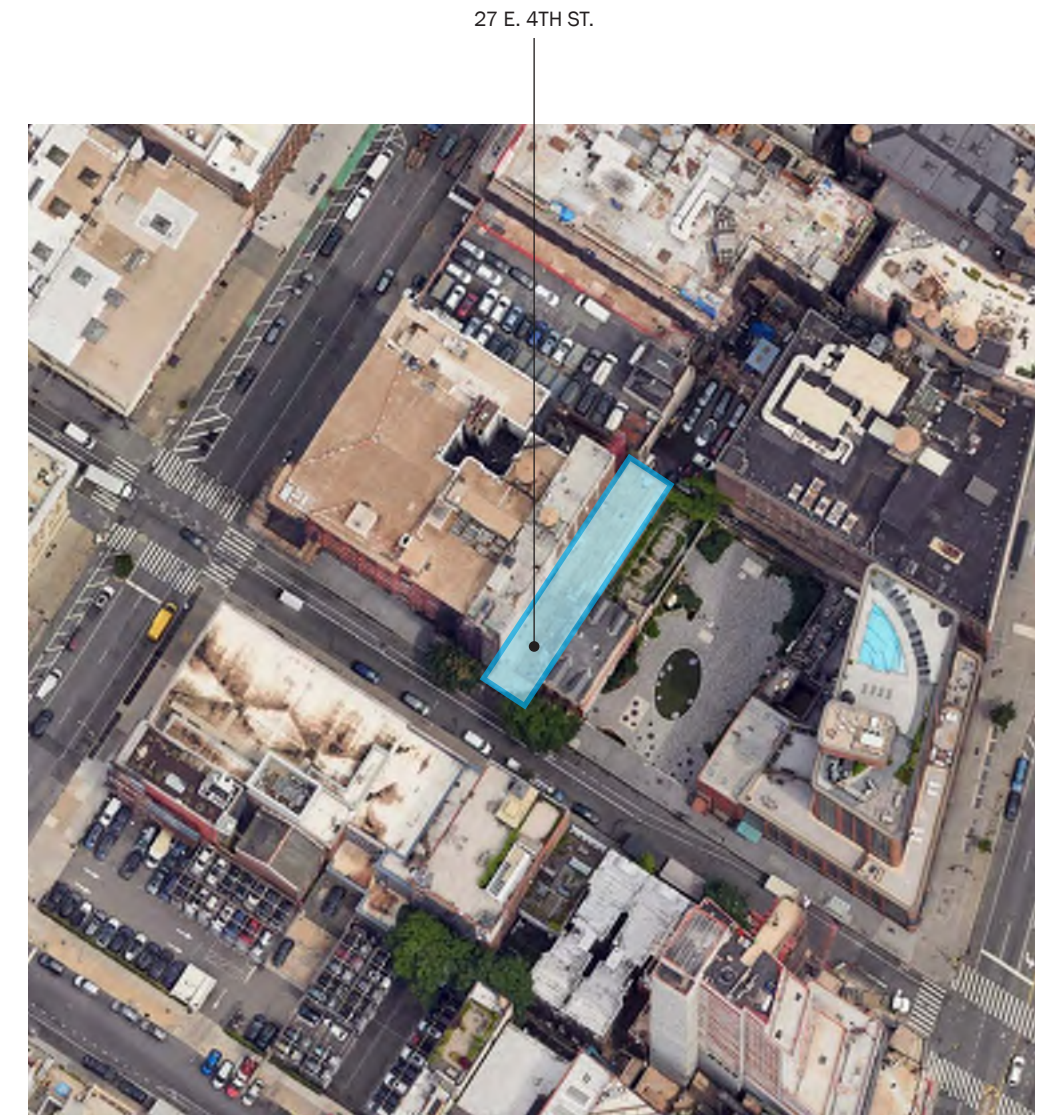

Aerial View (via Google Earth)

27 EAST 4TH STREET — LOCATION



DXA studio

© DXA studio
dxastudio.com

894 6th Avenue
5th Floor
NYC 10001
T 212 874 0567



GILSANZ MURRAY STEFICEK
Structural Engineers and Building Envelope Consultants

SCALE N/A
CLIENT
PROJECT NUMBER 25.29
DATE FEB 11, 2026

05

History (from Historic Designation Report)

“This one-story structure designed by architect Herman Kron was built for Paramount Filing Stations, Inc. c.1945 for use as a garage and repair shop. The building, which is currently used as storage for food carts, has a simple brick facade and large vehicle entrance.”

*LPC Certificate of Appropriateness
(Issued 04/06/18)*

“With regard to this proposal, the Commission found that the one-story garage building is not one of the buildings for which the historic district is designated, and therefore its demolition will not diminish the special architectural and historic character of the NoHo historic district extension.”



EXISTING GARAGE AND REPAIR SHOP, CONSTRUCTED 1946

DEMOLITION OF SINGLE STORY GARAGE - **APPROVED**

27 EAST 4TH STREET — **EXISTING SINGLE STORY GARAGE**



DXA studio
© DXA studio
dxastudio.com

894 6th Avenue
5th Floor
NYC 10001
T 212 874 0567



GILSANZ MURRAY STEFICEK
Structural Engineers and Building Envelope Consultants

SCALE N/A
CLIENT
PROJECT NUMBER 25.29
DATE FEB 11, 2026

06



27 E. 4TH ST.

27 EAST 4TH STREET — EXISTING CONDITIONS

SCALE	N/A
CLIENT	
PROJECT NUMBER	25.29
DATE	FEB 11, 2026



DXA studio
© DXA studio
dxastudio.com

894 6th Avenue
5th Floor
NYC 10001
T 212 874 0567



GMS **GILSANZ MURRAY STEFICEK**
Structural Engineers and Building Envelope Consultants

SCALE	N/A
CLIENT	
PROJECT NUMBER	25.29
DATE	FEB 11, 2026



A - EAST STREET VIEW - FROM E 4TH ST & BOWERY



C - EXISTING CONDITIONS - STABLE COURT, FACING REAR OF LOT 72

LEGEND

27 E. 4TH ST.

MERCHANT'S HOUSE I (INDIVIDUAL LANDMARK)



B - WEST STREET VIEW - FROM E 4TH ST & LAFAYETTE



D - EXISTING CONDITIONS - STABLE COURT, ALLEY ACCESS TO BOWERY

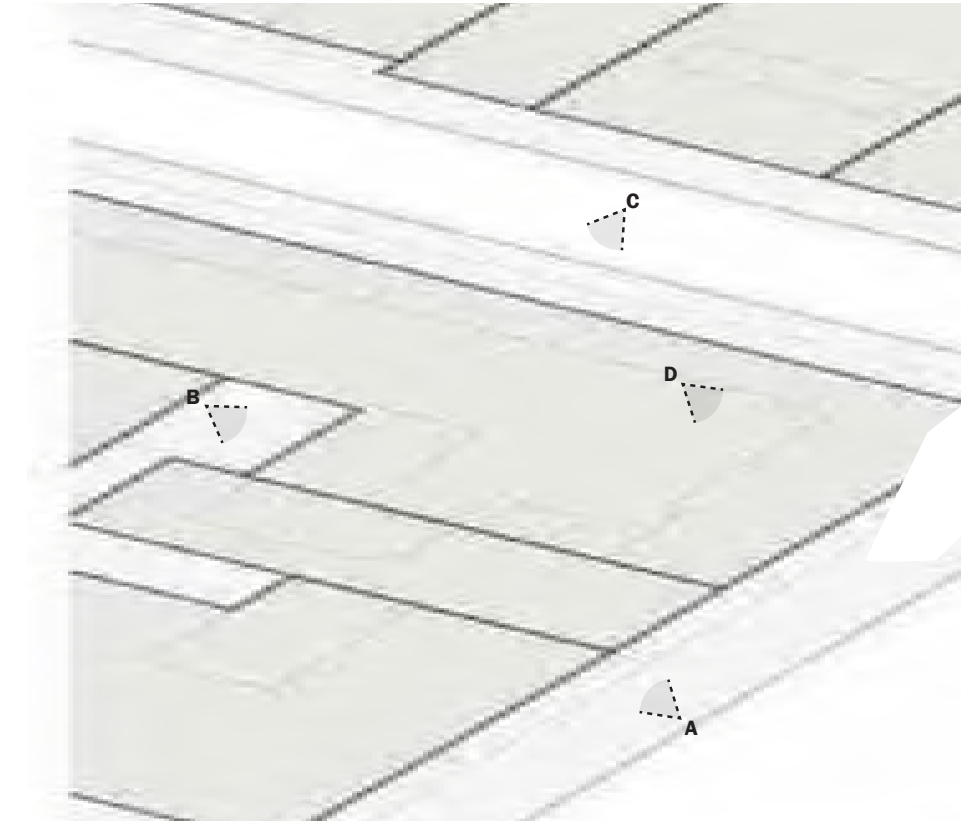

KEY PLAN

27 EAST 4TH STREET — EXISTING CONTEXT

SCALE N/A
 CLIENT
 PROJECT NUMBER 25.29
 DATE FEB 11, 2026



DXA studio

© DXA studio
 dxastudio.com

894 6th Avenue
 5th Floor
 NYC 10001
 T 212 874 0567



GILSANZ MURRAY STEFICEK
 Structural Engineers and Building Envelope Consultants

PREVIOUS PROPOSED DESIGN (2018)



PERSPECTIVE ELEVATION

TIMELINE (2018 DESIGN)

LPC Public Hearing:	9/4/11
Parks Dept. Approval:	1/17/14
Final LPC Public Meeting:	4/8/14
LPC Status Update Letter:	4/8/14
Certificate of Appropriateness:	4/6/18
Planning Commission Approval:	2018
City Council Denial:	2018

PREVIOUS APPROVED PROPOSED DESIGN (2021)



PERSPECTIVE ELEVATION

TIMELINE (2021 DESIGN)

LPC Public Hearing:	1/12/21
Final LPC Public Meeting:	12/12/23
LPC Status Update Letter:	2/29/24

27 EAST 4TH STREET — PROJECT HISTORY



DXA studio

© DXA studio
dxastudio.com

894 6th Avenue
5th Floor
NYC 10001
T 212 874 0567



GILSANZ MURRAY STEFICEK
Structural Engineers and Building Envelope Consultants

SCALE	N/A
CLIENT	
PROJECT NUMBER	25.29
DATE	FEB 11, 2026

CONDITIONS OF 2024 LPC STATUS UPDATE LETTER

EXTENSIVE MONITORING AND REMEDIATION PROGRAM TO BE IN PLACE FOR MERCHANT'S HOUSE MUSEUM PRIOR TO PERMIT:

- 1) CONFIRMATION OF VIBRATION TOLERANCE STANDARD.
- 2) SURVEY OF EXISTING PLASTER CONDITIONS.
- 3) STABILIZATION PLAN.
- 4) REMEDIAL PLAN AND FUND TO ADDRESS ANY PHYSICAL DAMAGE INCURRED BY THE PROPOSED WORK, INCLUDING PLASTER REPAIR.
- 5) WEEKLY PROJECT STATUS REPORTS UNTIL COMPLETION OF EXTERIOR WORK.
- 6) SITE VISITS DURING FOUNDATION WORK.



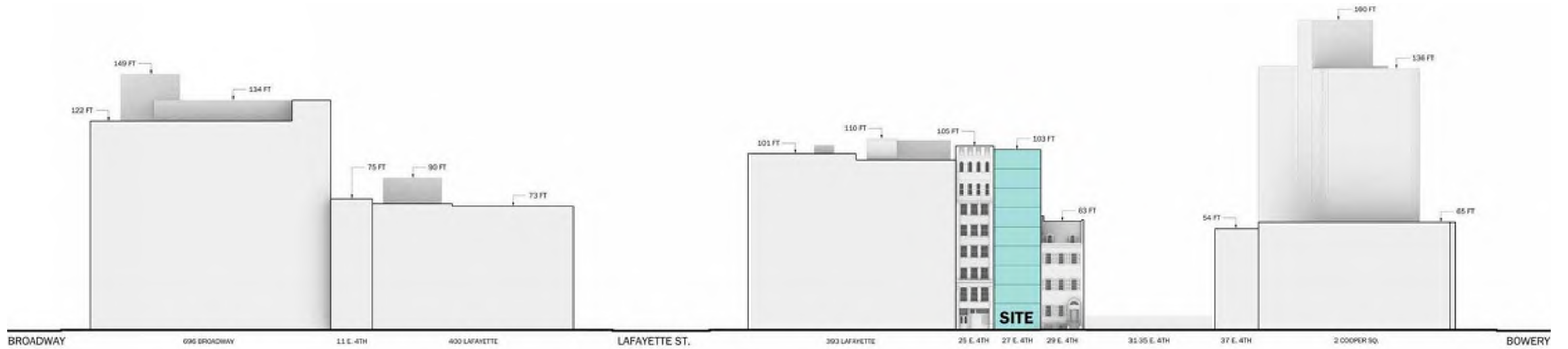

E. 4th STREET NORTH ELEVATION



400 LAFAYETTE, 1890
COMMERCIAL



393 LAFAYETTE, 1885
COMMERCIAL



25 EAST 4TH ST., 1900
RESIDENTIAL



29 EAST 4TH ST., 1832
INSTITUTIONAL



31 - 35 EAST 4TH ST., 1900
PARK



37 EAST 4TH ST., 1900
RESIDENTIAL

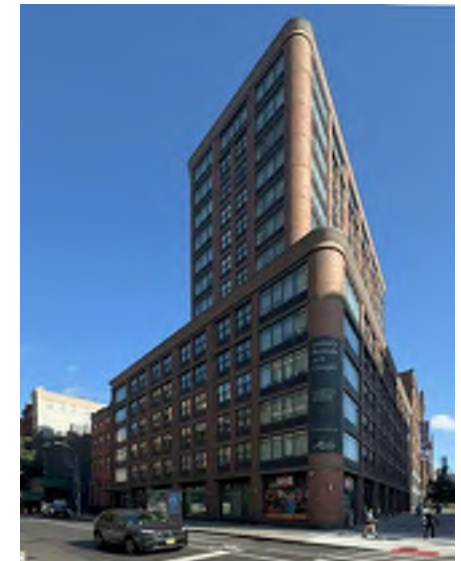

2 COOPER SQ., 2009
RESIDENTIAL

27 EAST 4TH STREET — SCALE OF STREET

SCALE N/A
CLIENT N/A
PROJECT NUMBER 25.29
DATE FEB 11, 2026



DXA studio
© DXA studio
dxastudio.com

894 6th Avenue
5th Floor
NYC 10001
T 212 874 0567



GILSANZ MURRAY STEFICEK
Structural Engineers and Building Envelope Consultants

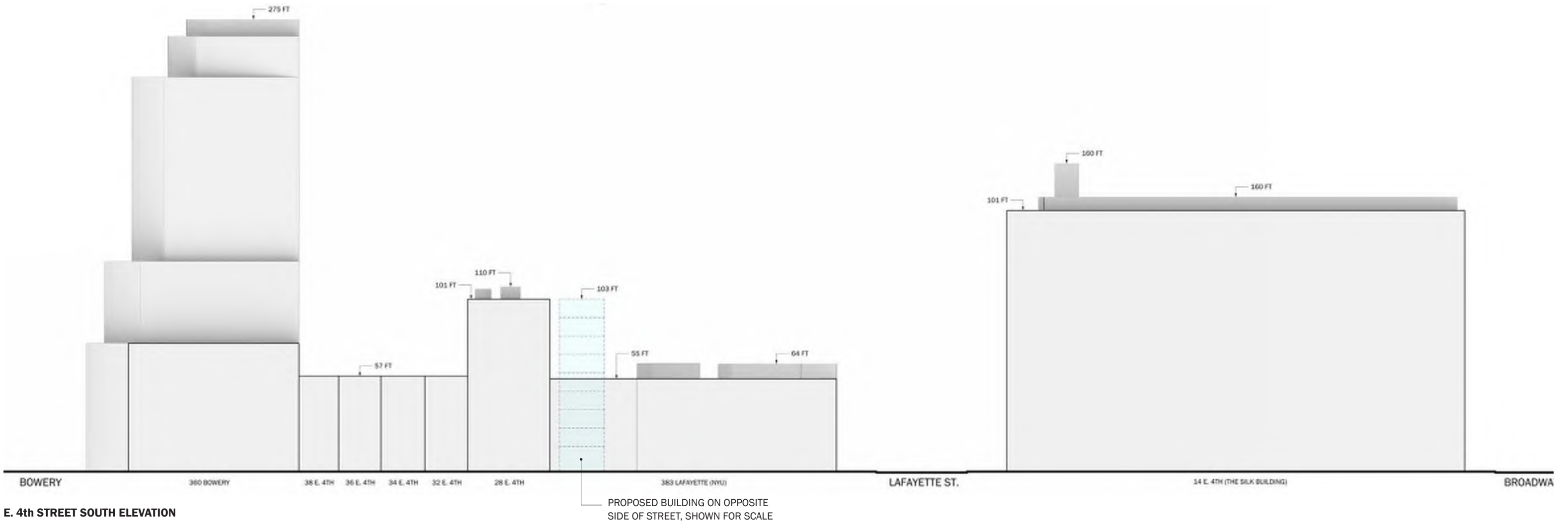

358 BOWERY, 1915
COMMERCIAL



38 EAST 4TH ST., 1910
RESIDENTIAL



34-36 EAST 4TH ST., 1910
RESIDENTIAL



32 EAST 4TH ST., 1900
RESIDENTIAL



28 EAST 4TH ST., 1900
RESIDENTIAL



383 LAFAYETTE, 1900
COMMERCIAL + OFFICE

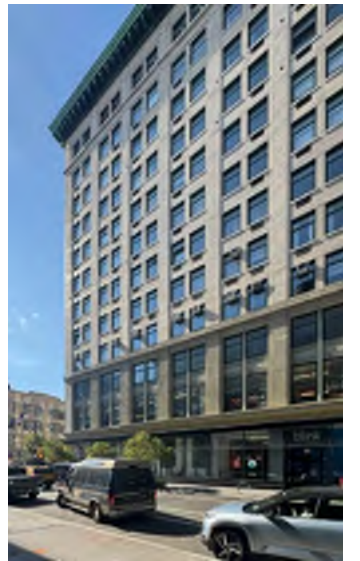

14 E.4th ST., 1912
COMMERCIAL + RESIDENTIAL

27 EAST 4TH STREET — SCALE OF STREET



DXA studio
© DXA studio
dxastudio.com
894 6th Avenue
5th Floor
NYC 10001
T 212 874 0567



GMS GILSANZ MURRAY STEFICEK
Structural Engineers and Building Envelope Consultants

SCALE N/A
CLIENT N/A
PROJECT NUMBER 25.29
DATE FEB 11, 2026

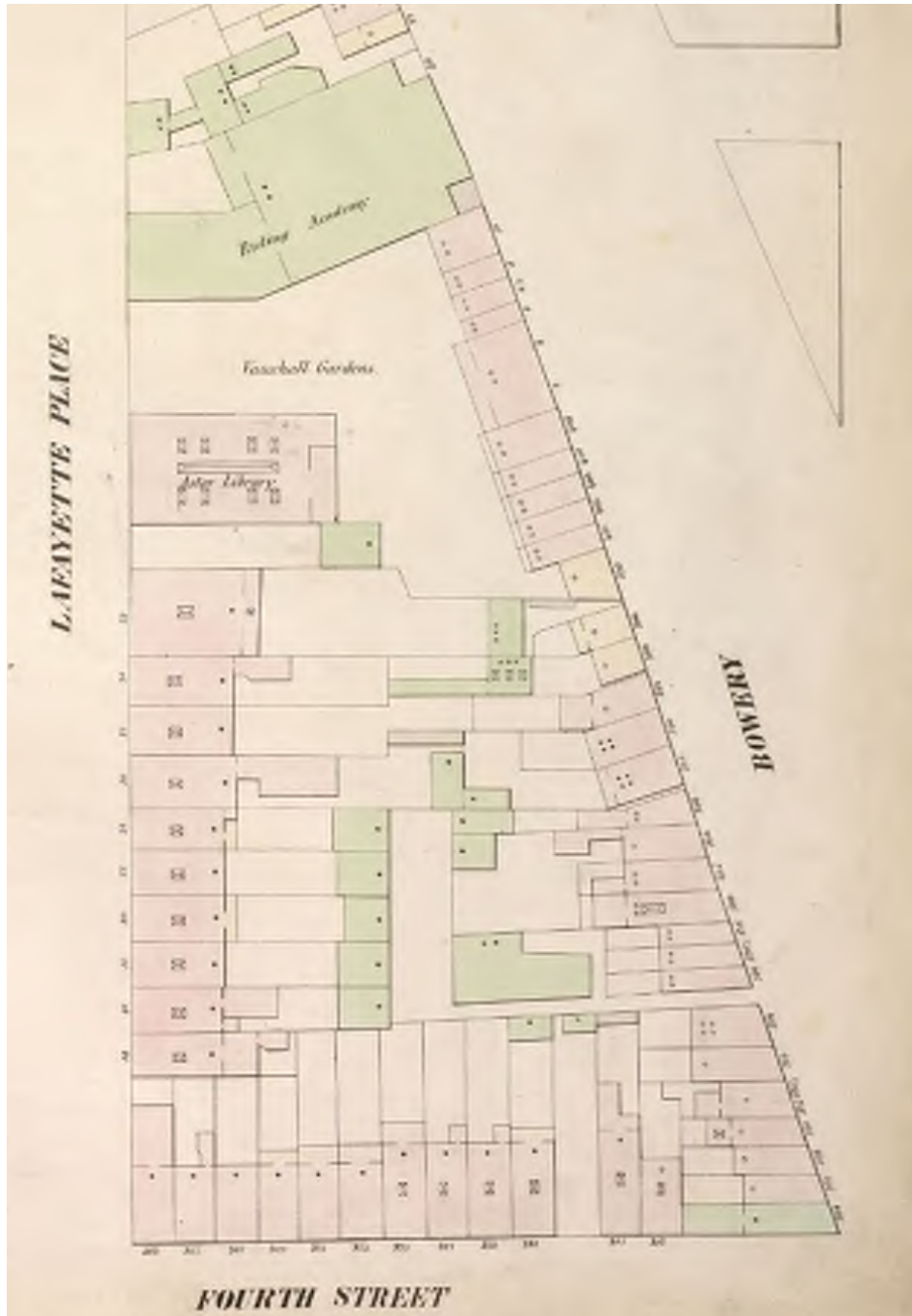

1854 Perris Map. (NYPL)

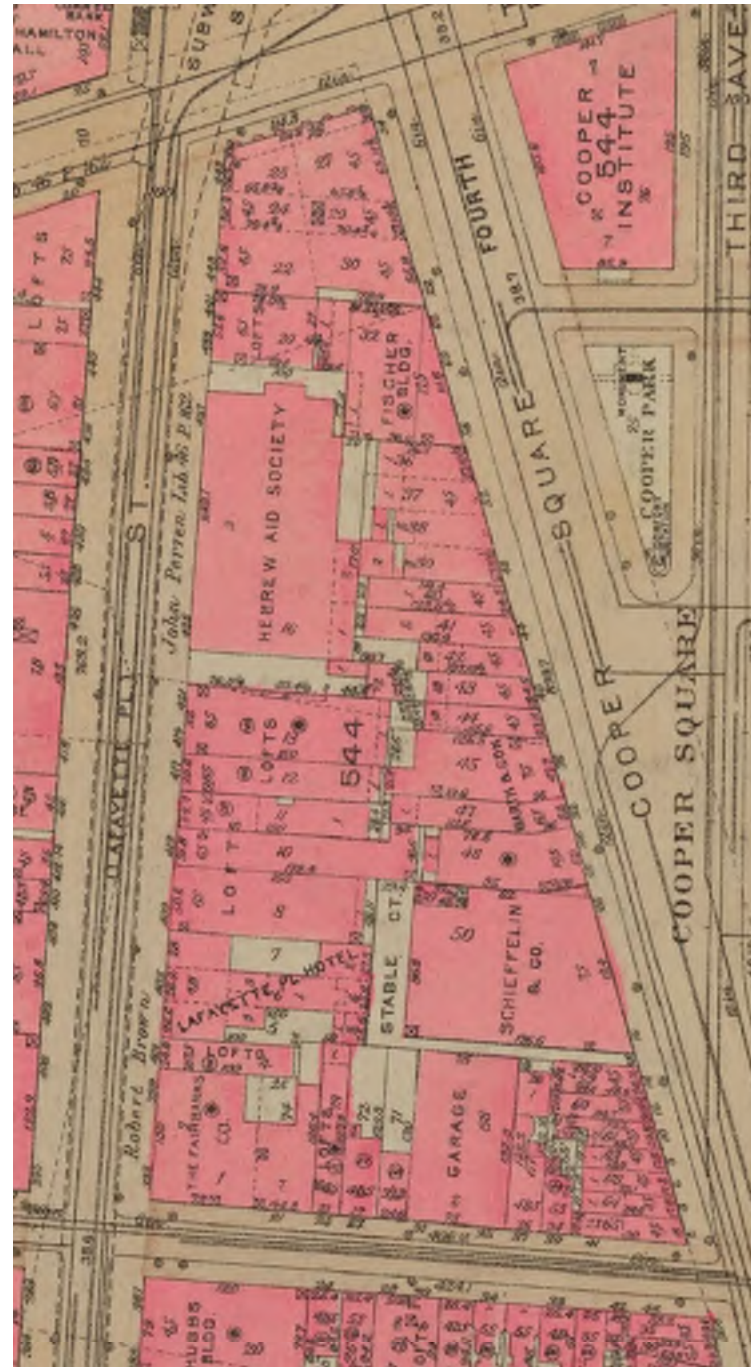

1930 Bromley Map. (NYPL)

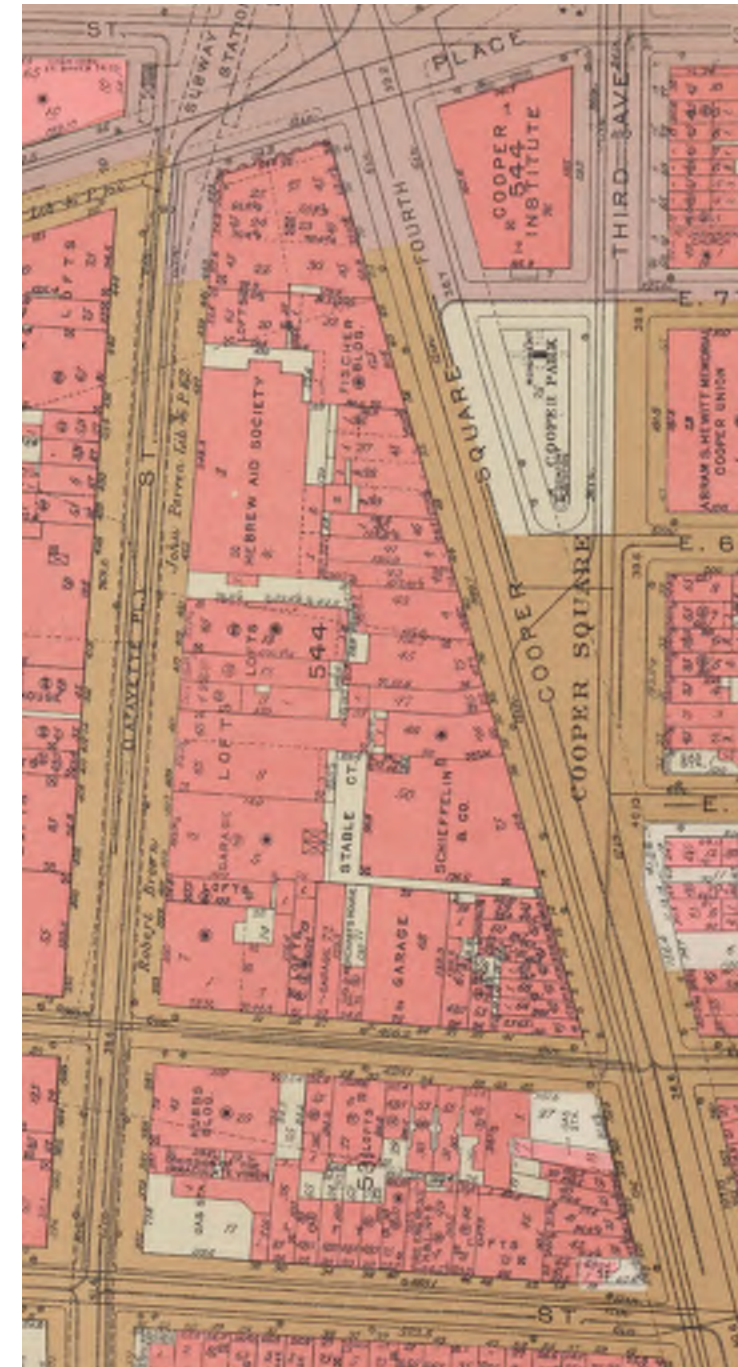

1955 Bromley Map. (NYPL)

27 EAST 4TH STREET – SITE EVOLUTION



DXA studio

© DXA studio
dxastudio.com

894 6th Avenue
5th Floor
NYC 10001
T 212 874 0567



GILSANZ MURRAY STEFICEK
Structural Engineers and Building Envelope Consultants

SCALE N/A
CLIENT
PROJECT NUMBER 25.29
DATE FEB 11, 2026

27 E. 4TH ST.



1923: 27 East 4th Street (G. Chinn, NYPL)

27 E. 4TH ST.



1940's tax photo, 27 East 4th Street (NYC Municipal Archive)

27 E. 4TH ST.



1980's tax photo, 27 East 4th Street (NYC Municipal Archive)

“The majority of loft construction in the NoHo Historic District Extension occurred between 1890- – 1900, with nineteen of the area’s twenty-five store and loft buildings completed within this ten-year period.” – NoHo Historic District Extension Designation Report, page 13.

27 EAST 4TH STREET – HISTORIC PHOTOS



DXA studio

© DXA studio
dxastudio.com

894 6th Avenue
5th Floor
NYC 10001
T 212 874 0567



GILSANZ MURRAY STEFICEK
Structural Engineers and Building Envelope Consultants

SCALE N/A
CLIENT
PROJECT NUMBER 25.29
DATE FEB 11, 2026



21 Bond St.
Renaissance Revival Style (Buchman & Deisler, 1893)



30 Bond St.
Renaissance Revival Style (Cleverdon & Putzel, 1892)



43 Great Jones St.
Romanesque Revival Style (Graul Frohne, 1893)



25 E. 4th St.
Romanesque Revival Style (Graul Frohne, 1893)

“By the latter part of the nineteenth century, the NoHo Historic District Extension was becoming a full-fledged commercial and manufacturing center. Twenty-five store-and-loft buildings were constructed in the district extension between 1868-70 and 1912.” - NoHo Historic District Extension Designation Report, page 12 – 13.

27 EAST 4TH STREET – DISTRICT PRECEDENTS: STORE & LOFT BUILDINGS



DXA studio
© DXA studio
dxastudio.com
894 6th Avenue
5th Floor
NYC 10001
T 212 874 0567



SCALE N/A
CLIENT
PROJECT NUMBER 25.29
DATE FEB 11, 2026



30-36 Great Jones St.,
1940's tax photo (NYC Municipal Archive)

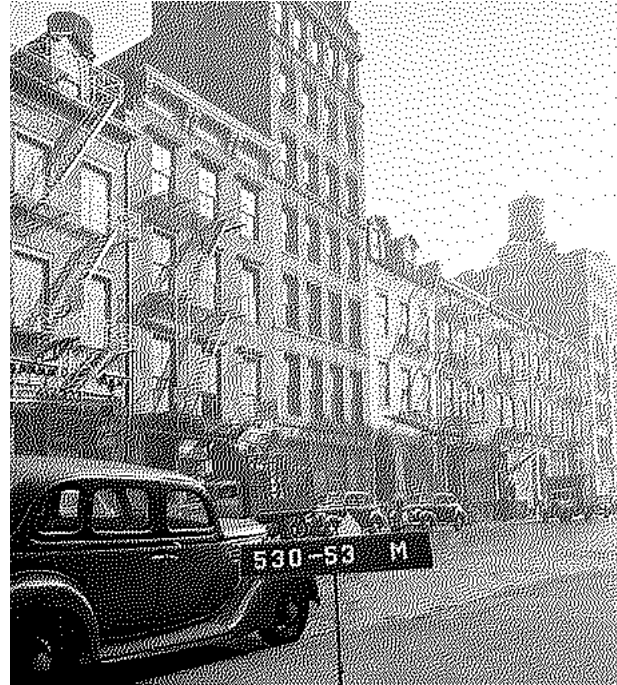

30 Bond St.,
1940's tax photo (NYC Municipal Archive)



20-24 Bond St.,
(via Google)



57-51 Great Jones St.
(via Google)

“These lofts, which were designed by many of the leading architects of the day in a variety of then-fashionable revival styles, towered over the residential buildings with which they intermingled. At five to eight stories in height and one to three lots in width, their arrival profoundly changed the scale of the neighborhood and heralded the appearance of the modern-day NoHo Historic District Extension.” – NoHo Historic District Extension Designation Report, page 12 – 13.

27 EAST 4TH STREET – DISTRICT CONTEXT : MIXING BUILDING TYPE & SCALE



DXA studio
© DXA studio
dxastudio.com
894 6th Avenue
5th Floor
NYC 10001
T 212 874 0567



SCALE N/A
CLIENT
PROJECT NUMBER 25.29
DATE FEB 11, 2026



11 Great Jones St.
(Morris Adjimi Architects, 2016)



41 Bond St.
(DDG Partners, 2011)



25 Great Jones St.
(BKSK Architects)



363 Lafayette St.
(Morris Adjimi Architects, 2018)

45 Great Jones St.
(Beyer Blinder Belle)

27 EAST 4TH STREET – LPC APPROVALS WITHIN THE DISTRICT



DXA studio
© DXA studio
dxastudio.com

894 6th Avenue
5th Floor
NYC 10001
T 212 874 0567



GILSANZ MURRAY STEFICEK
Structural Engineers and Building Envelope Consultants

SCALE N/A
CLIENT
PROJECT NUMBER 25.29
DATE FEB 11, 2026

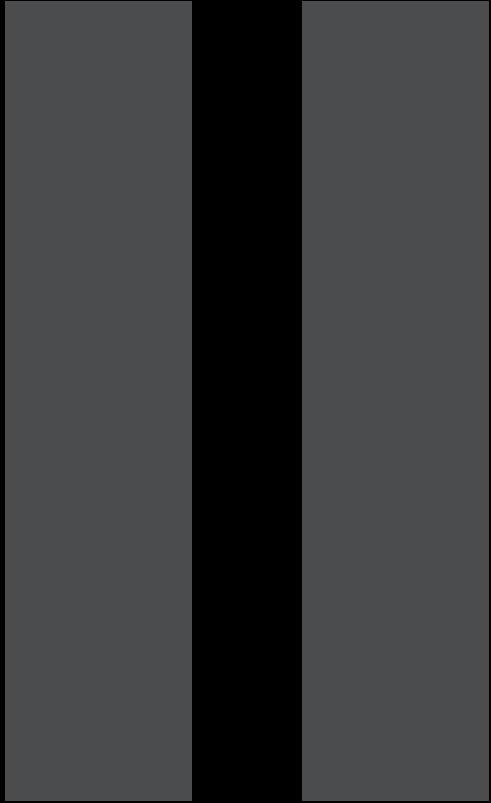

PROPOSED DESIGN

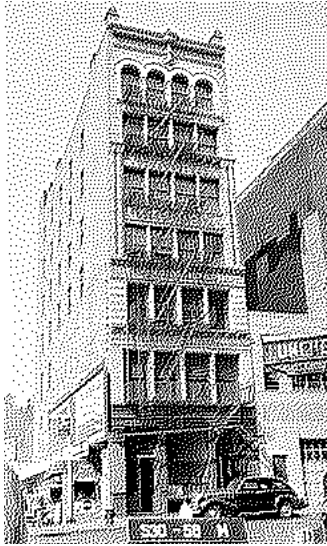

20 Bond St.
Chuck Close's Studio



24 Bond St.
Robert Maplethorpe's Residence

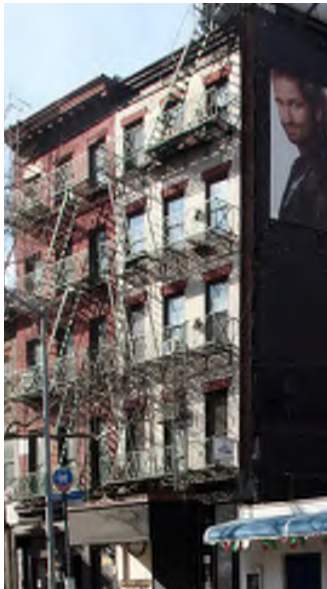

356 Bowery
Cy Twombly Studio



57 Great Jones St.
Jean-Michel Basquiat's Residence

Robert Rauschenberg,
381 Lafayette St.

Chuck Close,
20 Bond St.

Jonathan Borofsky,
22 Bond St.

Robert Maplethorpe,
24 Bond St.

Cy Twombly,
356 Bowery

Jean-Michel Basquiat,
57 Great Jones St.

Lawrence Weiner,
13 Bleecker St.



NOHO Historic Extension District Map
Artist Residences / Studios

27 EAST 4TH STREET – NOHO'S LEGACY OF ART & CREATIVITY



DXA studio
© DXA studio
dxastudio.com

894 6th Avenue
5th Floor
NYC 10001
T 212 874 0567



GILSANZ MURRAY STEFICEK
Structural Engineers and Building Envelope Consultants

SCALE N/A
CLIENT
PROJECT NUMBER 25.29
DATE FEB 11, 2026



Jean-Michel Basquiat in his NY studio & apartment at 57 Great Jones St, 1985.

Credit: The estate of Jean-Michel Basquiat / ADAG, Paris, London 2019
Photoby Tseng Kwong Chi. Muna Tseng Dance Projects, Inc Via Sotheby's Website.



Chuck Close on the corner outside his studio at Bond & Lafayette St. In 2006. His studio was just to the right of the vacant lot.

(Photo by Jefferson Siegel)



Cy Twombly in front of 356 Bowery in the 1960's.

(Photo by Eliot Elisofan via Artica.Edu)



Jonathan Borofsky

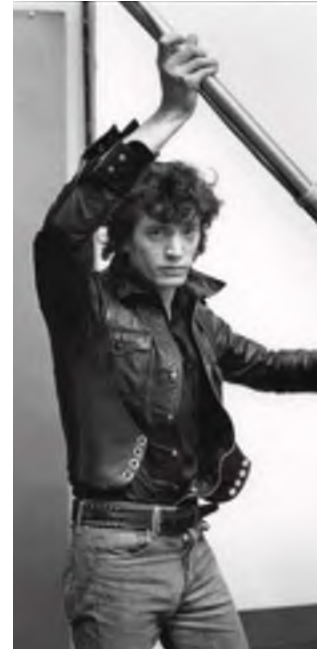

Robert Mapplethorpe in his studio & home at 24 Bond St., 1979.

(Photo by Fred W. McDarrah / MUUS Collection, Via nycigbtsites.org)



Robert Rauschenberg at his studio.



Lawrence Weiner



Sol Lewitt at his studio.



57 Great Jones St.
Jean-Michel Basquiat

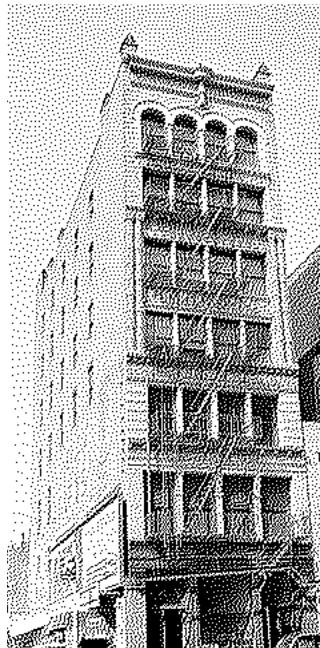

20 Bond St.
Chuck Close



356 Bowery
Cy Twombly



22 Bond St.
Jonathan Borofsky



24 Bond St.
Robert Mapplethorpe



381 Lafayette St.
Robert Rauschenberg

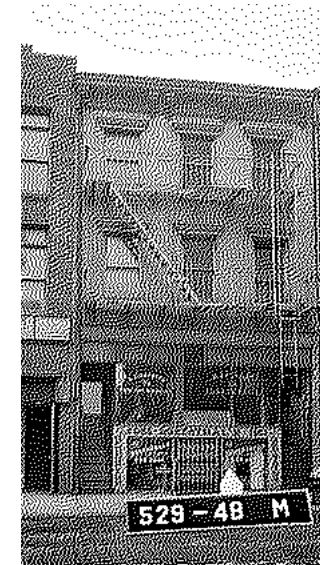

13 Bleecker St.
Lawrence Weiner



Sol Lewitt

27 EAST 4TH STREET – DESIGN INSPIRATION - NOHO ARTISTS



DXA studio

© DXA studio
dxastudio.com

894 6th Avenue
5th Floor
NYC 10001
T 212 874 0567



GILSANZ MURRAY STEFICEK
Structural Engineers and Building Envelope Consultants

SCALE N/A
CLIENT
PROJECT NUMBER 25.29
DATE FEB 11, 2026

20

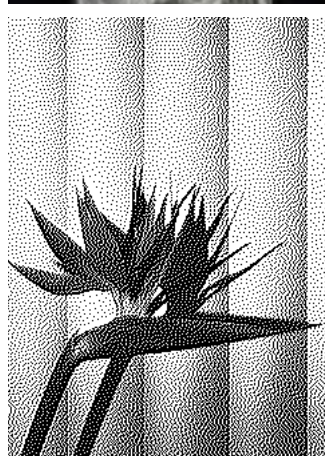
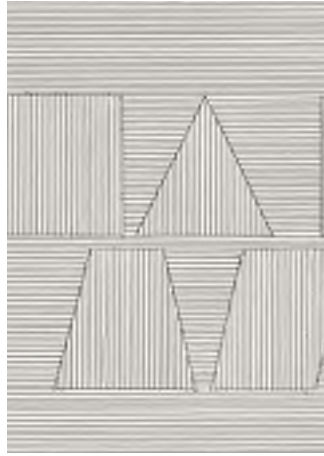

Jean-Michel Basquiat

Chuck Close

Cy Twombly

Jonathan Borofsky

Robert Maplethorpe

Robert Rauschenberg

Lawrence Weiner

Sol Lewitt

27 EAST 4TH STREET — DESIGN INSPIRATION - NOHO ARTISTS



DXA studio
© DXA studio
dxastudio.com

894 6th Avenue
5th Floor
NYC 10001
T 212 874 0567



GILSANZ MURRAY STEFICEK
Structural Engineers and Building Envelope Consultants

SCALE N/A
CLIENT
PROJECT NUMBER 25.29
DATE FEB 11, 2026

21

SCULPTURAL ELEMENTS



24 Bond St.

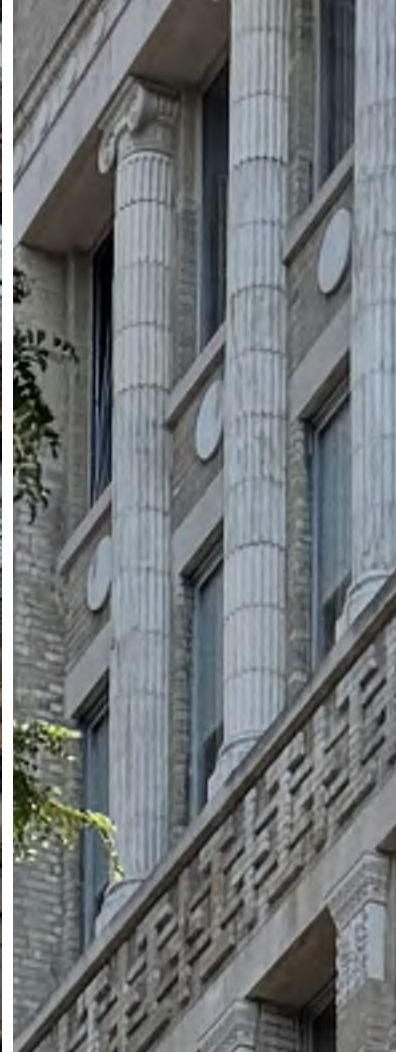

50 Bond St.

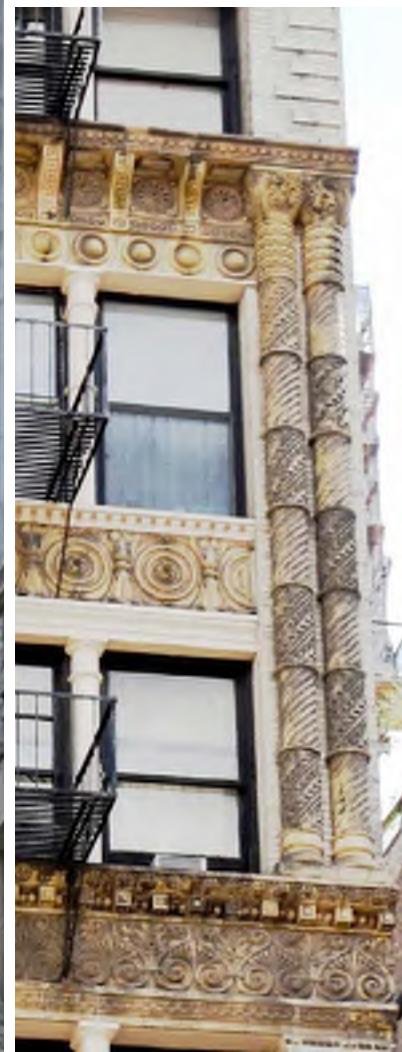

20 Bond St



330 Bowery

DECORATIVE SPANDRELS



34-36 East 4th St.



47 Great Jones St..



47 Great Jones St..

27 EAST 4TH STREET — DESIGN INSPIRATION - DISTRICT ORNAMENT



DXA studio

© DXA studio
dxastudio.com

894 6th Avenue
5th Floor
NYC 10001
T 212 874 0567



GILSANZ MURRAY STEFICEK
Structural Engineers and Building Envelope Consultants

SCALE N/A
CLIENT
PROJECT NUMBER 25.29
DATE FEB 11, 2026

22

ELABORATE CORNICICES



34-36 East 4th St.

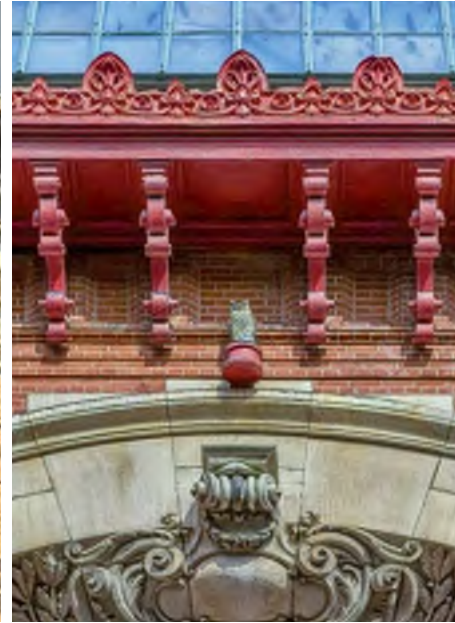

42-44 Great Jones St.



17-19 Bond St.



393-399 Lafayette St.

ORGANIC MOTIFS

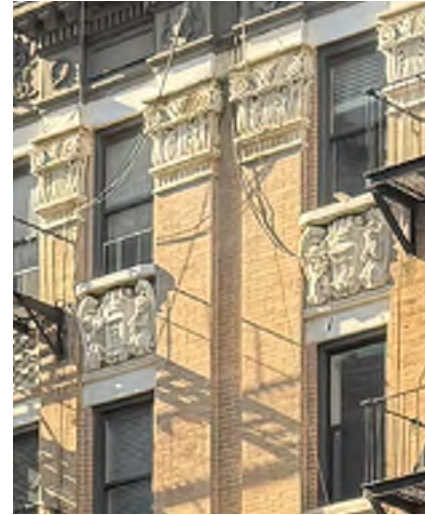

34-36 East 4th St.



42-44 Great Jones St.



24 Bond St.

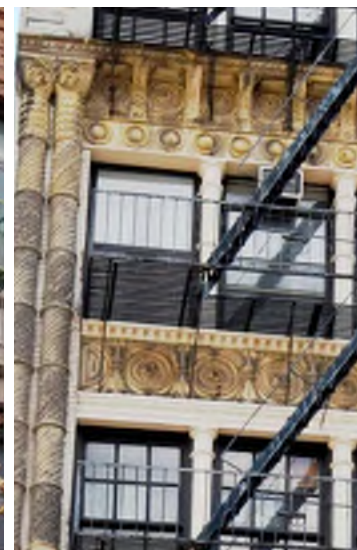

20 Bond St.

ARTICULATED MASONRY



17-19 Bond St.



393-399 De Vinne Press Building

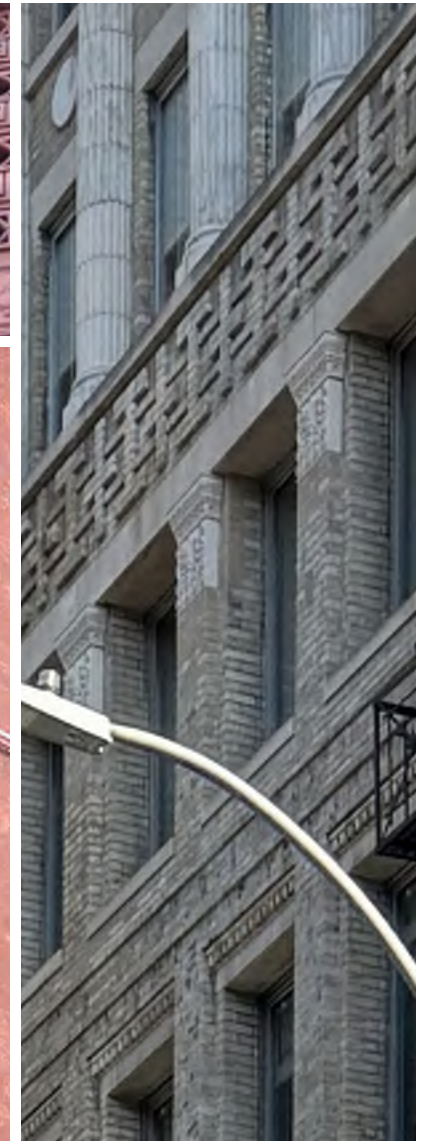

50 Bond St.

27 EAST 4TH STREET — DESIGN INSPIRATION - DISTRICT ORNAMENT



DXA studio

© DXA studio
dxastudio.com

894 6th Avenue
5th Floor
NYC 10001
T 212 874 0567



GILSANZ MURRAY STEFICEK
Structural Engineers and Building Envelope Consultants

SCALE N/A
CLIENT
PROJECT NUMBER 25.29
DATE FEB 11, 2026

23



27 EAST 4TH STREET — FACADE DESIGN - VISUALIZATION - STREET VIEW FROM EAST



DXA studio
© DXA studio
dxastudio.com

894 6th Avenue
5th Floor
NYC 10001
T 212 874 0567



GILSANZ MURRAY STEFICEK
Structural Engineers and Building Envelope Consultants

SCALE	N/A
CLIENT	
PROJECT NUMBER	25.29
DATE	FEB 11, 2026



27 EAST 4TH STREET — FACADE DESIGN - VISUALIZATION - STREET VIEW FROM SOUTH



DXA studio

© DXA studio
dxastudio.com

894 6th Avenue
5th Floor
NYC 10001
T 212 874 0567



GILSANZ MURRAY STEFICEK
Structural Engineers and Building Envelope Consultants

SCALE N/A
CLIENT
PROJECT NUMBER 25.29
DATE FEB 11, 2026



27 EAST 4TH STREET — FACADE DESIGN - VISUALIZATION - BASE VIEWS



DXA studio

© DXA studio
dxastudio.com

894 6th Avenue
5th Floor
NYC 10001
T 212 874 0567



GILSANZ MURRAY STEFICEK
Structural Engineers and Building Envelope Consultants

SCALE	N/A
CLIENT	
PROJECT NUMBER	25.29
DATE	FEB 11, 2026



27 EAST 4TH STREET — FACADE DESIGN - VISUALIZATION - BASE VIEWS



DXA studio

© DXA studio
dxastudio.com

894 6th Avenue
5th Floor
NYC 10001
T 212 874 0567



GILSANZ MURRAY STEFICEK
Structural Engineers and Building Envelope Consultants

SCALE	N/A
CLIENT	
PROJECT NUMBER	25.29
DATE	FEB 11, 2026

27



27 EAST 4TH STREET — FACADE DESIGN - VISUALIZATION - LIGHTING APPROACH



DXA studio

© DXA studio
dxastudio.com

894 6th Avenue
5th Floor
NYC 10001
T 212 874 0567



GILSANZ MURRAY STEFICEK
Structural Engineers and Building Envelope Consultants

SCALE	N/A
CLIENT	
PROJECT NUMBER	25.29
DATE	FEB 11, 2026

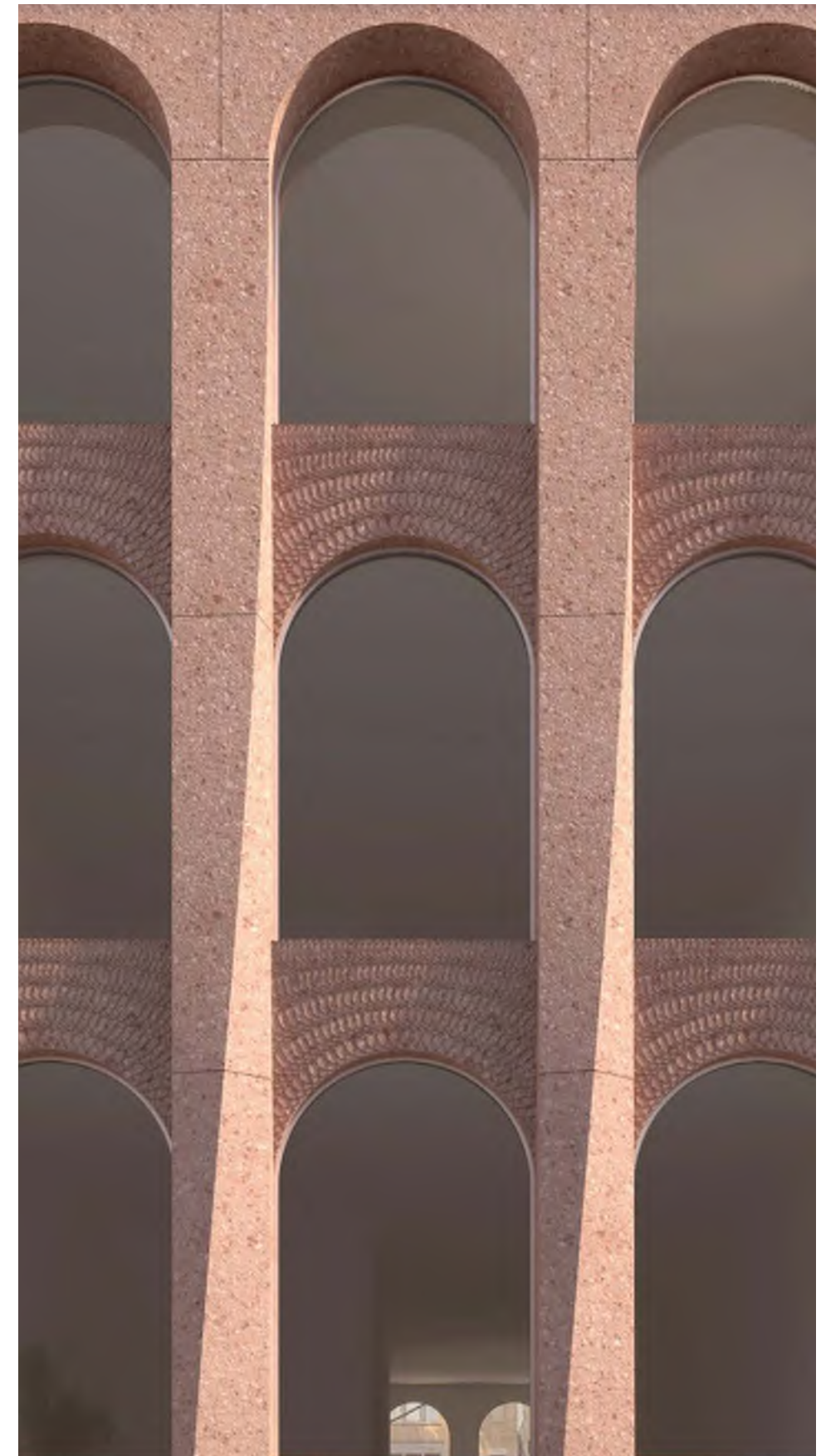

27 EAST 4TH STREET — FACADE DESIGN - VISUALIZATION - TYPICAL BAY & SPANDREL DETAIL



DXA studio

© DXA studio
dxastudio.com

894 6th Avenue
5th Floor
NYC 10001
T 212 874 0567



GILSANZ MURRAY STEFICEK
Structural Engineers and Building Envelope Consultants

SCALE	N/A
CLIENT	
PROJECT NUMBER	25.29
DATE	FEB 11, 2026



27 EAST 4TH STREET — **FACADE DESIGN - VISUALIZATION - CROWN & DETAIL**



DXA studio

© DXA studio
dxastudio.com

894 6th Avenue
5th Floor
NYC 10001
T 212 874 0567



GILSANZ MURRAY STEFICEK
Structural Engineers and Building Envelope Consultants

SCALE	N/A
CLIENT	
PROJECT NUMBER	25.29
DATE	FEB 11, 2026



27 EAST 4TH STREET — FACADE DESIGN - VISUALIZATION - CORNER CONDITION



DXA studio
© DXA studio
dxastudio.com

894 6th Avenue
5th Floor
NYC 10001
T 212 874 0567



GILSANZ MURRAY STEFICEK
Structural Engineers and Building Envelope Consultants

SCALE	N/A
CLIENT	
PROJECT NUMBER	25.29
DATE	FEB 11, 2026

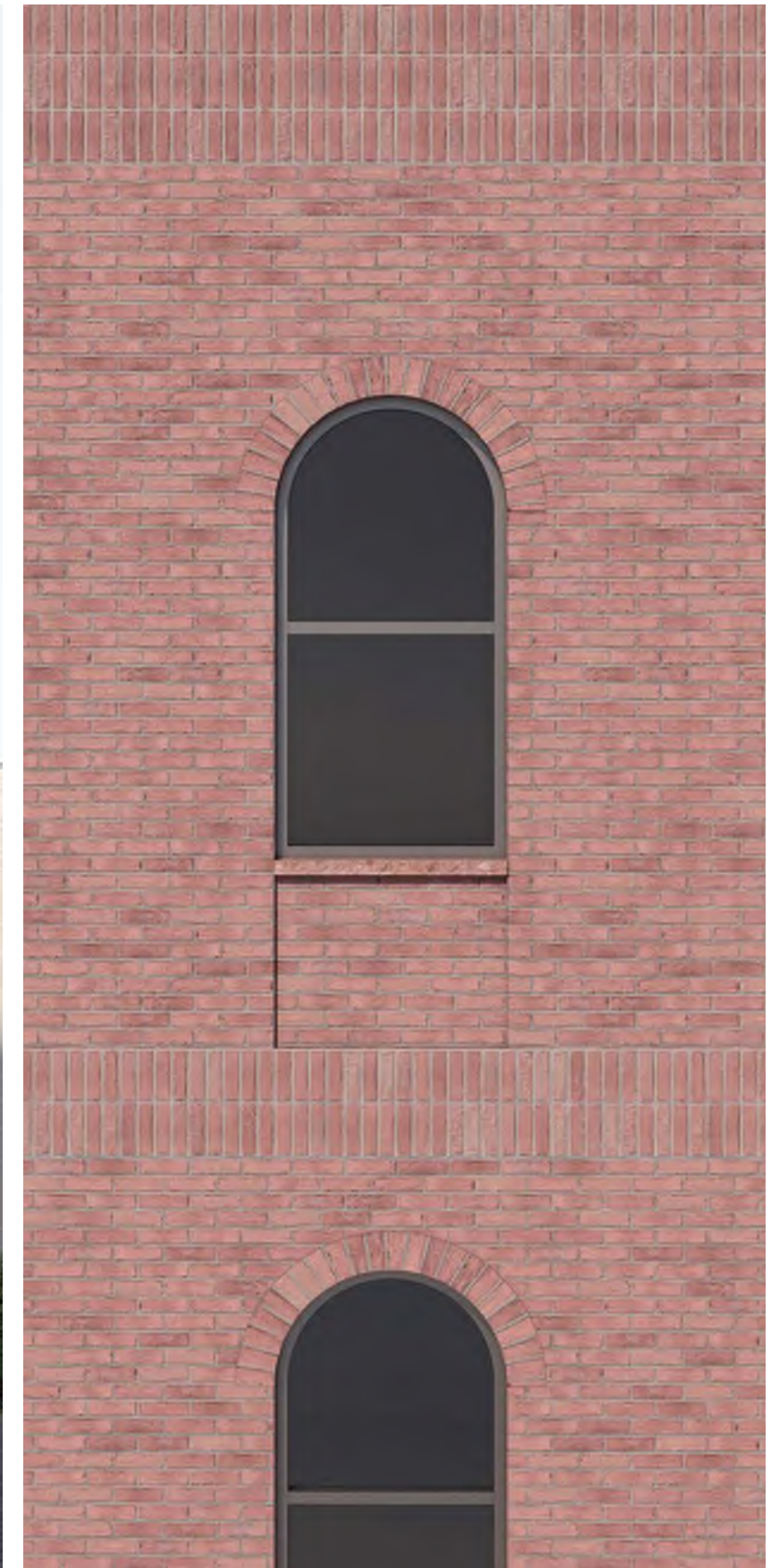

27 EAST 4TH STREET — FACADE DESIGN - VISUALIZATION - EAST FACADE STREET VIEW & DETAIL



DXA studio

© DXA studio
dxastudio.com

894 6th Avenue
5th Floor
NYC 10001
T 212 874 0567



GILSANZ MURRAY STEFICEK
Structural Engineers and Building Envelope Consultants

SCALE	N/A
CLIENT	
PROJECT NUMBER	25.29
DATE	FEB 11, 2026



27 E. 4th Rear Facade



B. View looking North from 27 E. 4th Rear Facade.

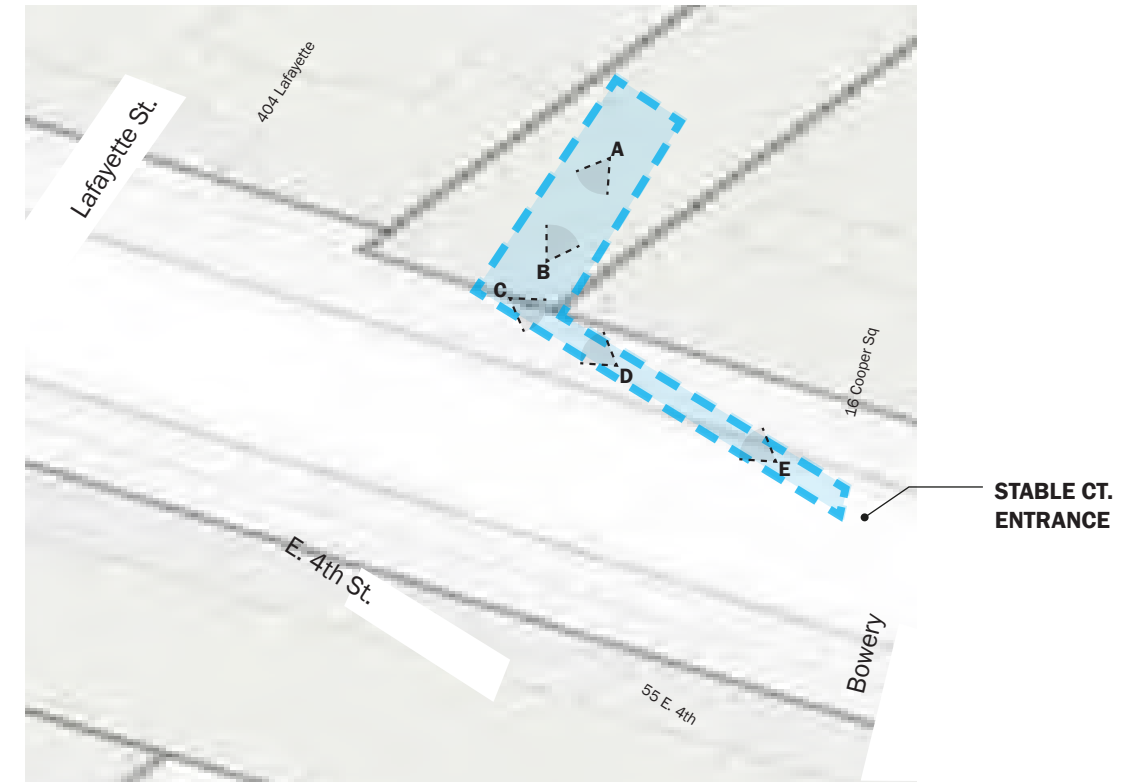

STABLE COURT EXISTING CONDITIONS
KEY PLAN

- LEGEND
- 27 E. 4TH ST.
 - MERCHANT'S HOUSE (INDIVIDUAL LANDMARK)
 - STABLE COURT



C. View Looking Towards Entrance and Bowery

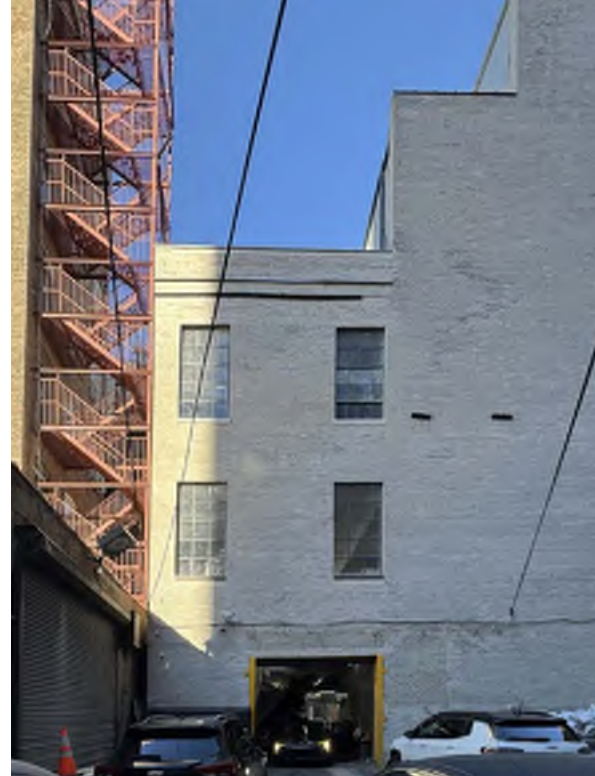

D. View of 404 Lafayette St.



E. View From Bowery

27 EAST 4TH STREET – STABLE COURT EXISTING CONDITIONS & KEY PLAN



DXA studio
894 6th Avenue
5th Floor
NYC 10001
T 212 874 0567
© DXA studio
dxastudio.com



GMS GILSANZ MURRAY STEFICEK
Structural Engineers and Building Envelope Consultants

SCALE N/A
CLIENT
PROJECT NUMBER 25.29
DATE FEB 11, 2026



STABLE COURT
KEY PLAN



27 EAST 4TH STREET – STABLE COURT PROPOSED REAR ALLEY LANDSCAPE PLAN



DXA studio

© DXA studio
dxastudio.com

894 6th Avenue
5th Floor
NYC 10001
T 212 874 0567



GILSANZ MURRAY STEFICEK
Structural Engineers and Building Envelope Consultants

SCALE N/A
CLIENT
PROJECT NUMBER 25.29
DATE FEB 11, 2026



27 EAST 4TH STREET — FACADE DESIGN - VISUALIZATION - REAR VIEW



DXA studio

© DXA studio
dxastudio.com

894 6th Avenue
5th Floor
NYC 10001
T 212 874 0567



GILSANZ MURRAY STEFICEK
Structural Engineers and Building Envelope Consultants

SCALE N/A
CLIENT
PROJECT NUMBER 25.29
DATE FEB 11, 2026

35



27 EAST 4TH STREET — FACADE DESIGN - VISUALIZATION - REAR VIEW



DXA studio

© DXA studio
dxastudio.com

894 6th Avenue
5th Floor
NYC 10001
T 212 874 0567



GILSANZ MURRAY STEFICEK
Structural Engineers and Building Envelope Consultants

SCALE	N/A
CLIENT	
PROJECT NUMBER	25.29
DATE	FEB 11, 2026

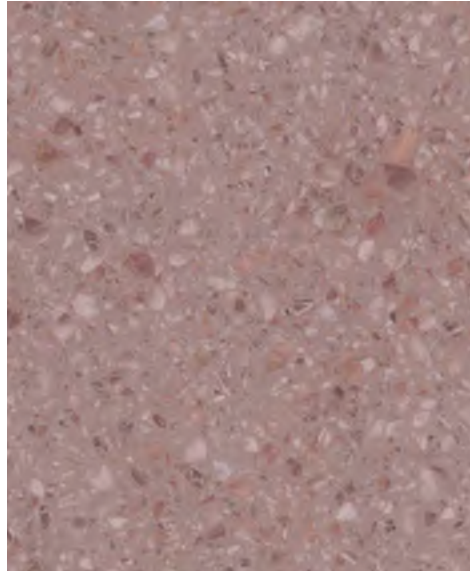

Cementitious Cast Panel Vertical, Cornice, & Spandrel Panels Treated For Terrazzo Like Appearance



Stone Base Water Course



Thermally Broken Steel Storefront System & Aluminum Window Units in Dark Bronze Finish



Beldin Belcrest 330 Brick at East and North Facade

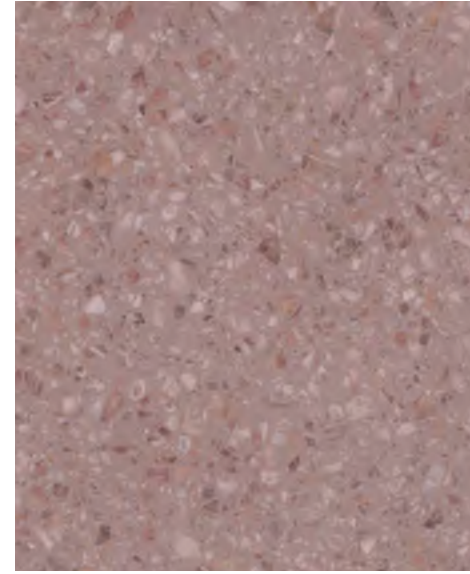

Precast Window Sills at East Facade



Corrugated Aluminum Bulkhead Siding Painted to Match Facade



Belgian Block Pavers at Rear Alley

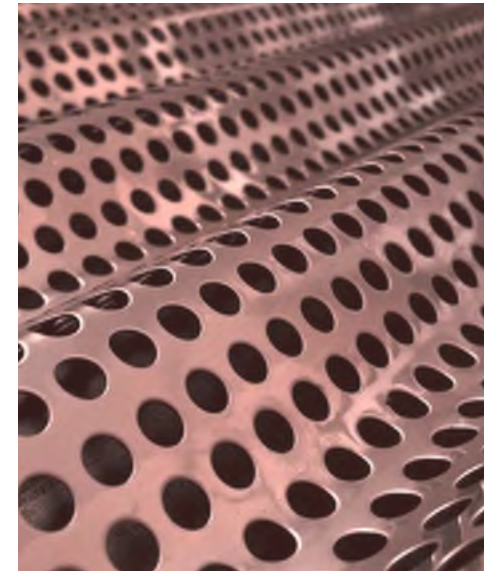

Corrugated Aluminum Perforated Mechanical Screen Enclosure Painted to Match Facade

27 EAST 4TH STREET – MATERIALS



DXA studio

© DXA studio
dxastudio.com

894 6th Avenue
5th Floor
NYC 10001
T 212 874 0567



GILSANZ MURRAY STEFICEK
Structural Engineers and Building Envelope Consultants

SCALE N/A
CLIENT
PROJECT NUMBER 25.29
DATE FEB 11, 2026



LINEAR UPLIGHT GRAZER RECESSED IN CORNICE X4

RECESSED SOFFIT MOUNTED LED DOWN LIGHT X 3. FINISH TO MATCH STORE FRONT

LINEAR UPLIGHT GRAZER RECESSED IN PAVEMENT X4

27 EAST 4TH STREET — **BASE DETAILS - LIGHTING & SIGNAGE**



DXA studio

© DXA studio
dxastudio.com

894 6th Avenue
5th Floor
NYC 10001
T 212 874 0567



GILSANZ MURRAY STEFICEK
Structural Engineers and Building Envelope Consultants

SCALE N/A
CLIENT
PROJECT NUMBER 25.29
DATE FEB 11, 2026

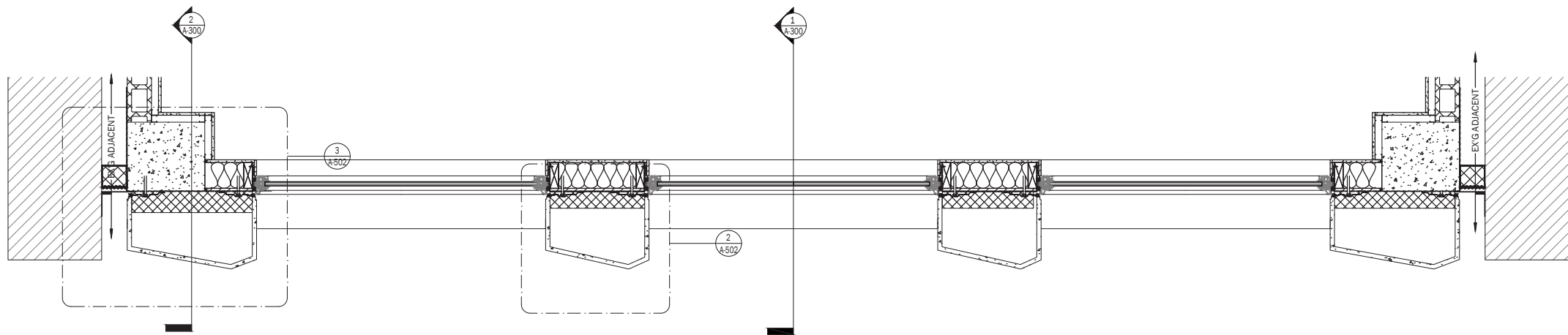

1 PLAN SECTION DTL - PANEL + WINDOW 3/4" = 1'-0"

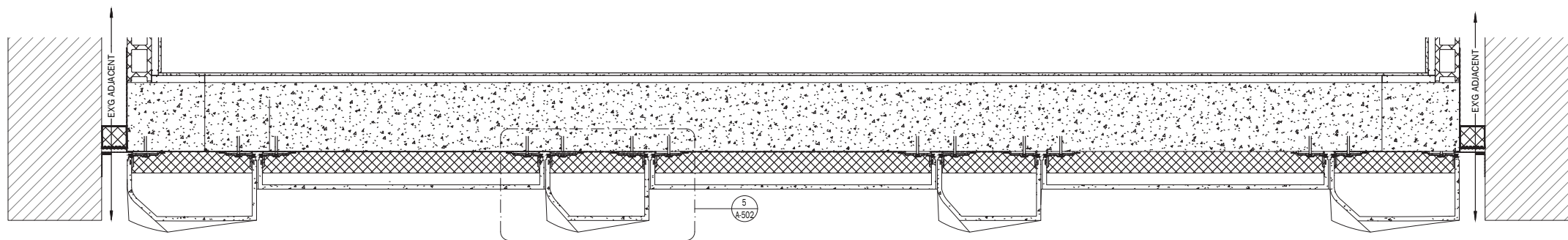

4 PLAN SECTION DTL - PANEL 3/4" = 1'-0"

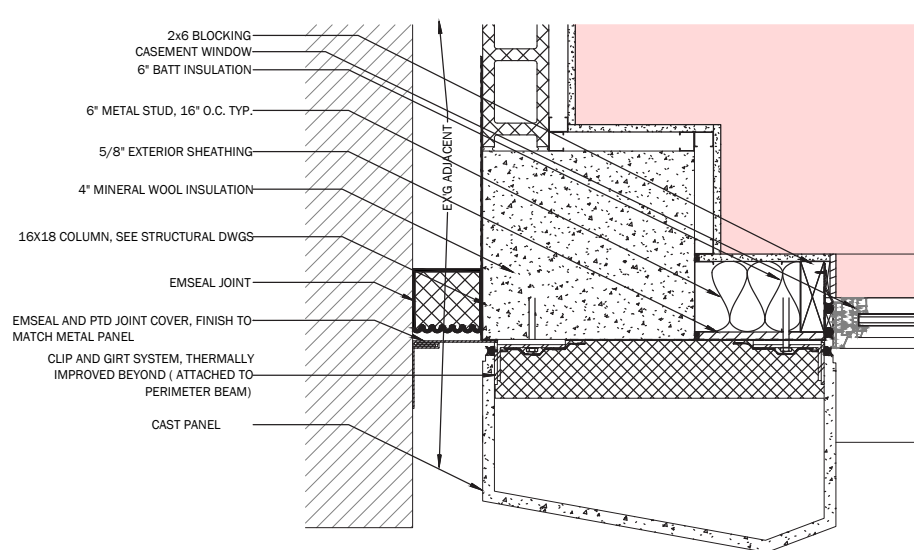

3 PLAN SECTION DTL - PANEL TO LOTLINE 1 1/2" = 1'-0"

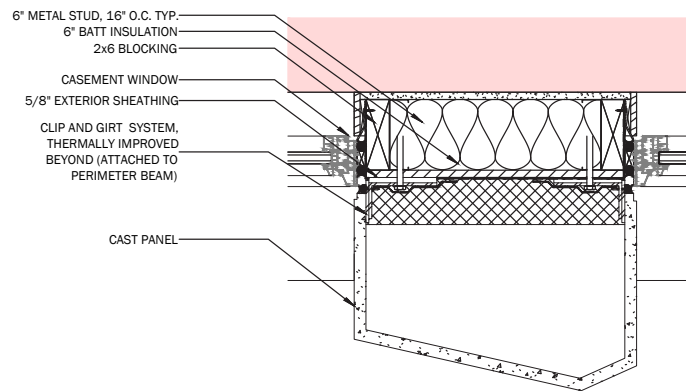

2 PLAN SECTION DETAIL - PANEL TO GLASS 1 1/2" = 1'-0"

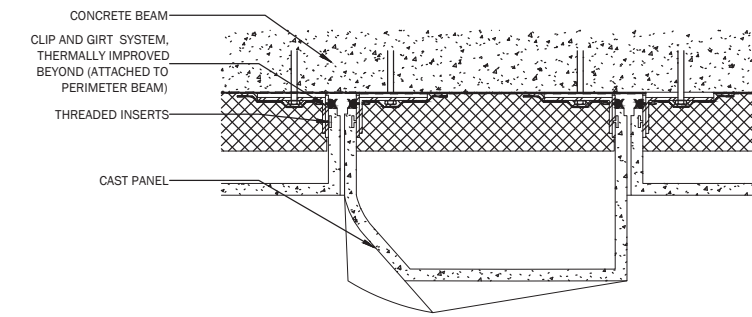

5 PLAN SECTION DETAIL - PANEL TO PANEL 1 1/2" = 1'-0"

27 EAST 4TH STREET — PLAN DETAILS



DXA studio
 © DXA studio
 dxastudio.com
 894 6th Avenue
 5th Floor
 NYC 10001
 T 212 874 0567



GMS GILSANZ MURRAY STEFICEK
 Structural Engineers and Building Envelope Consultants

SCALE N/A
 CLIENT
 PROJECT NUMBER 25.29
 DATE FEB 11, 2026

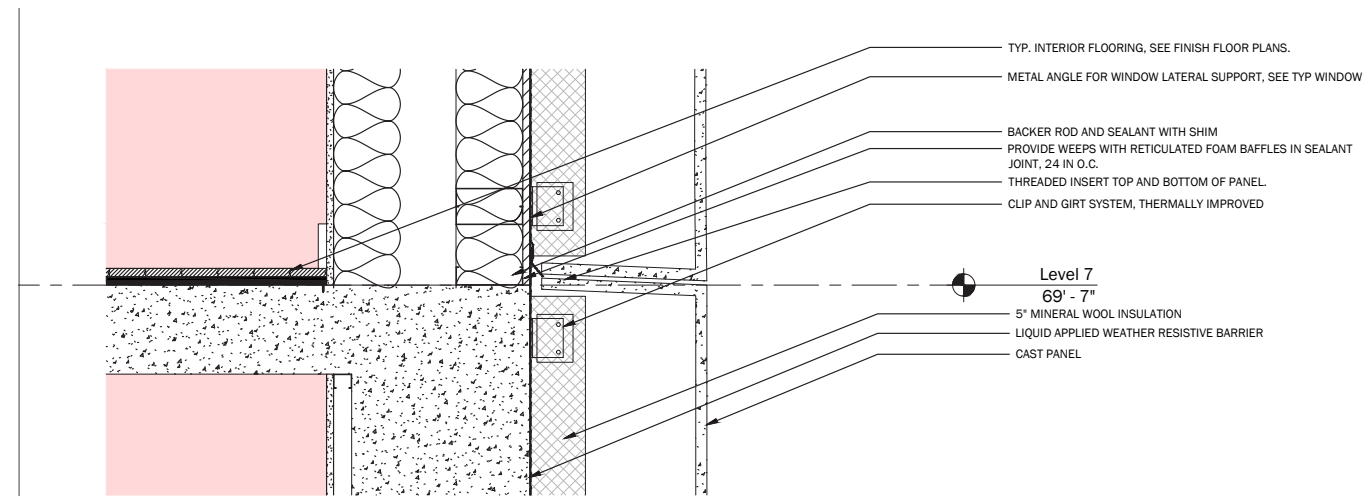

3 SECTION DTL - TYP. GFRC PANEL TO PANEL 1 1/2" = 1'-0"

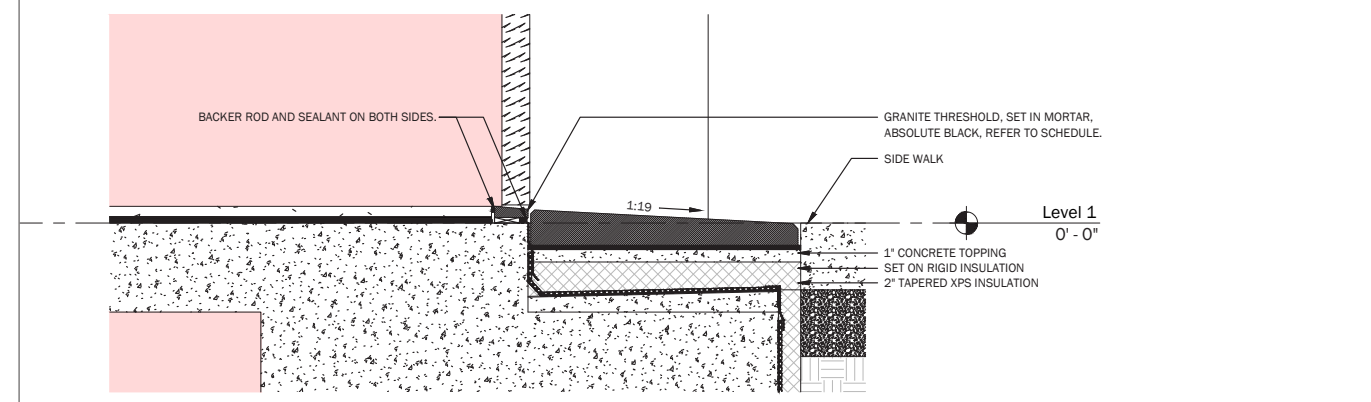
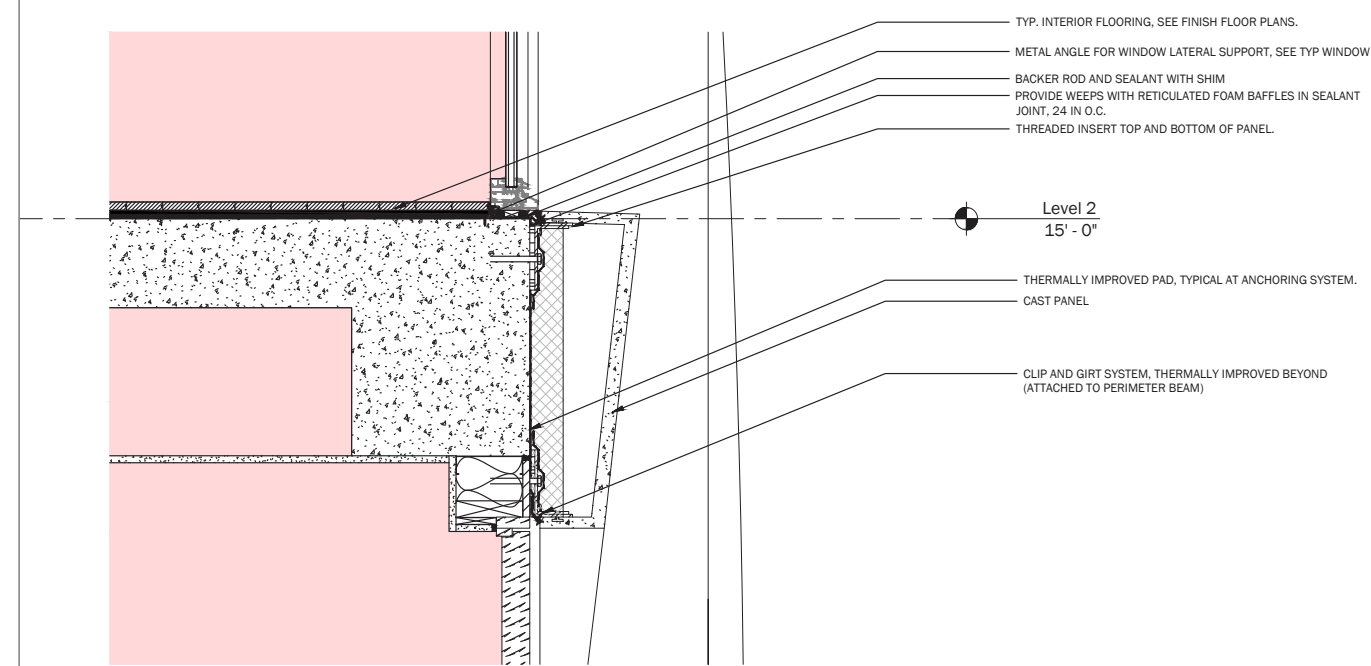

1 1 1/2" = 1'-0"

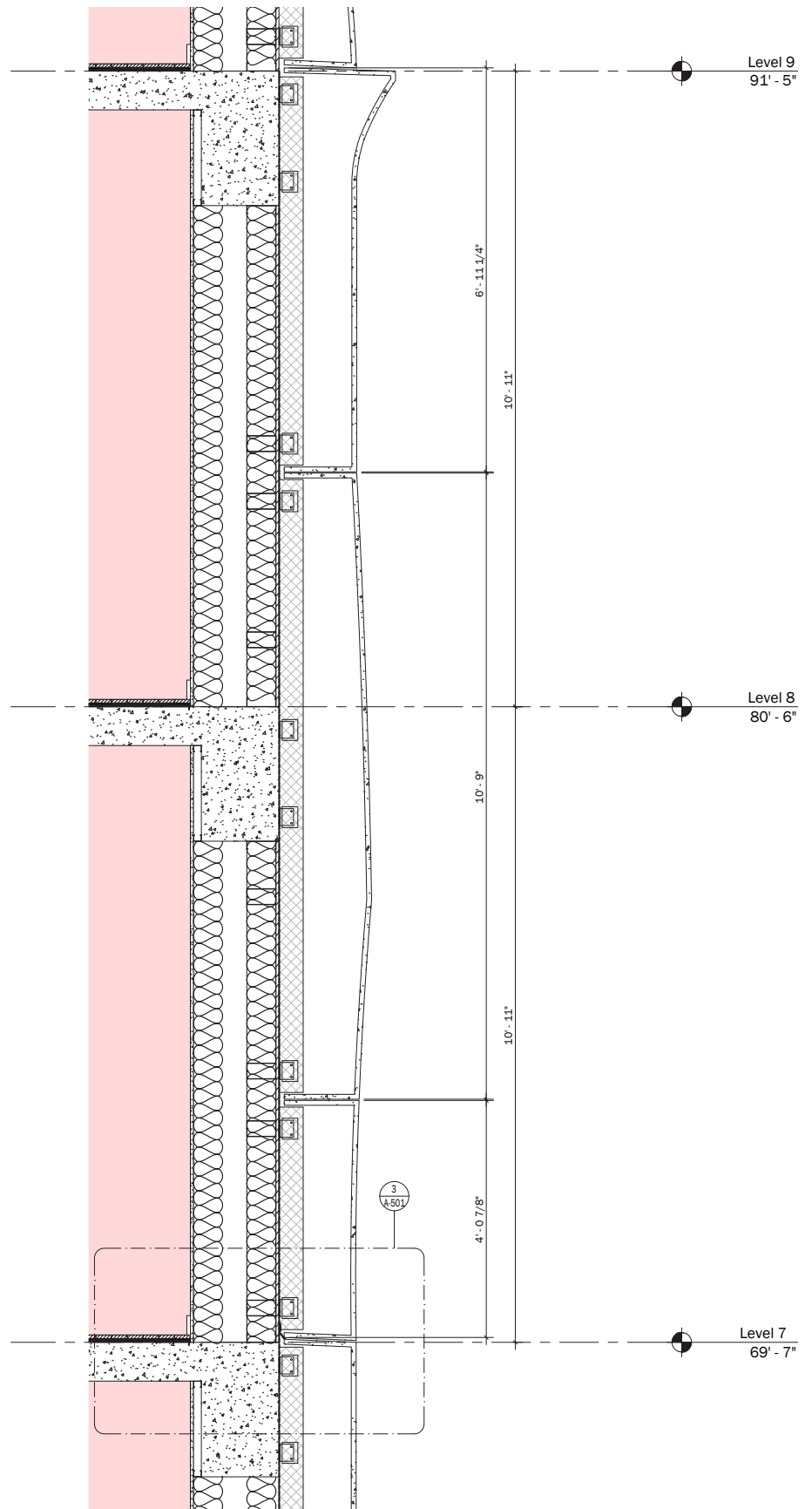

2 SECTION DTL. TYP. FULL PANEL FLR. TO FLR. 3/4" = 1'-0"

27 EAST 4TH STREET — WALL SECTIONS



DXA studio
 © DXA studio
 dxastudio.com
 894 6th Avenue
 5th Floor
 NYC 10001
 T 212 874 0567



SCALE N/A
 CLIENT N/A
 PROJECT NUMBER 25.29
 DATE FEB 11, 2026

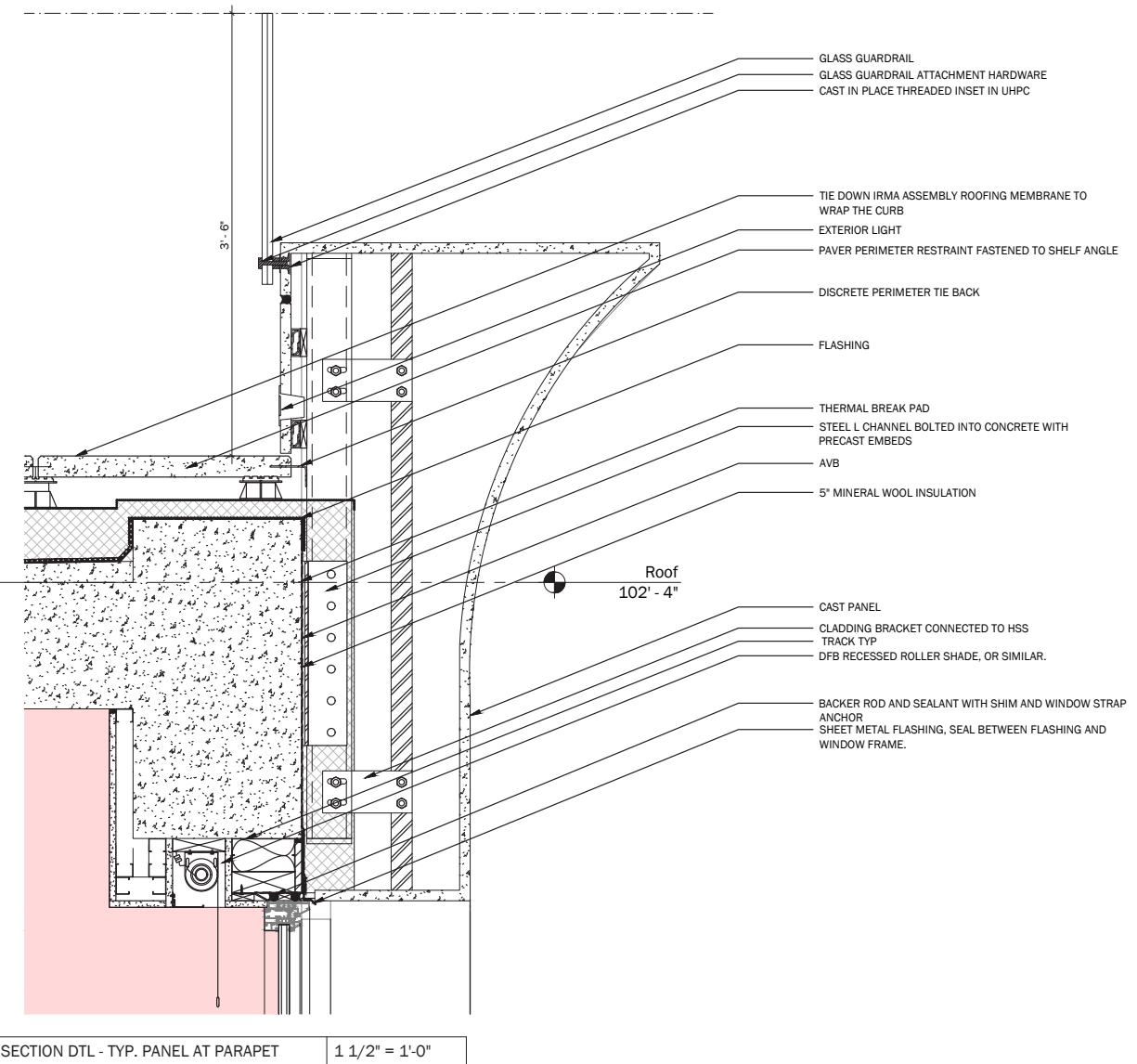
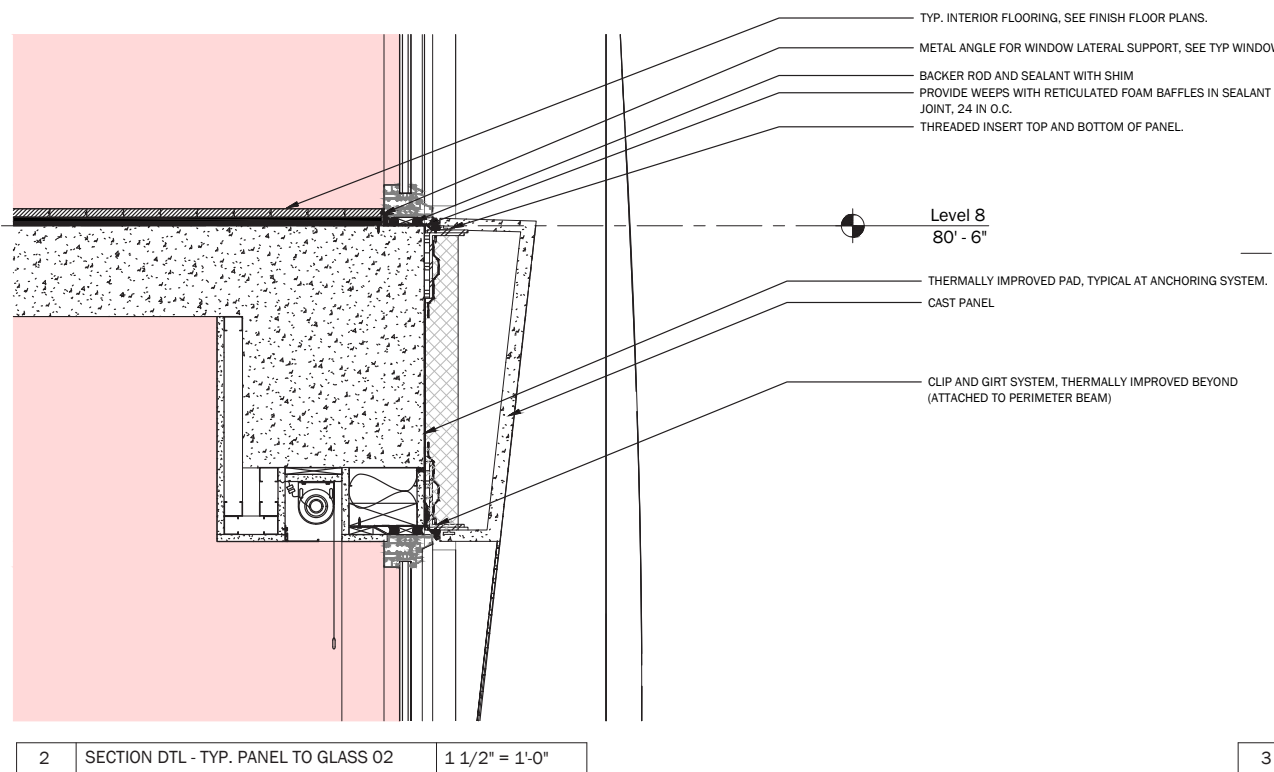
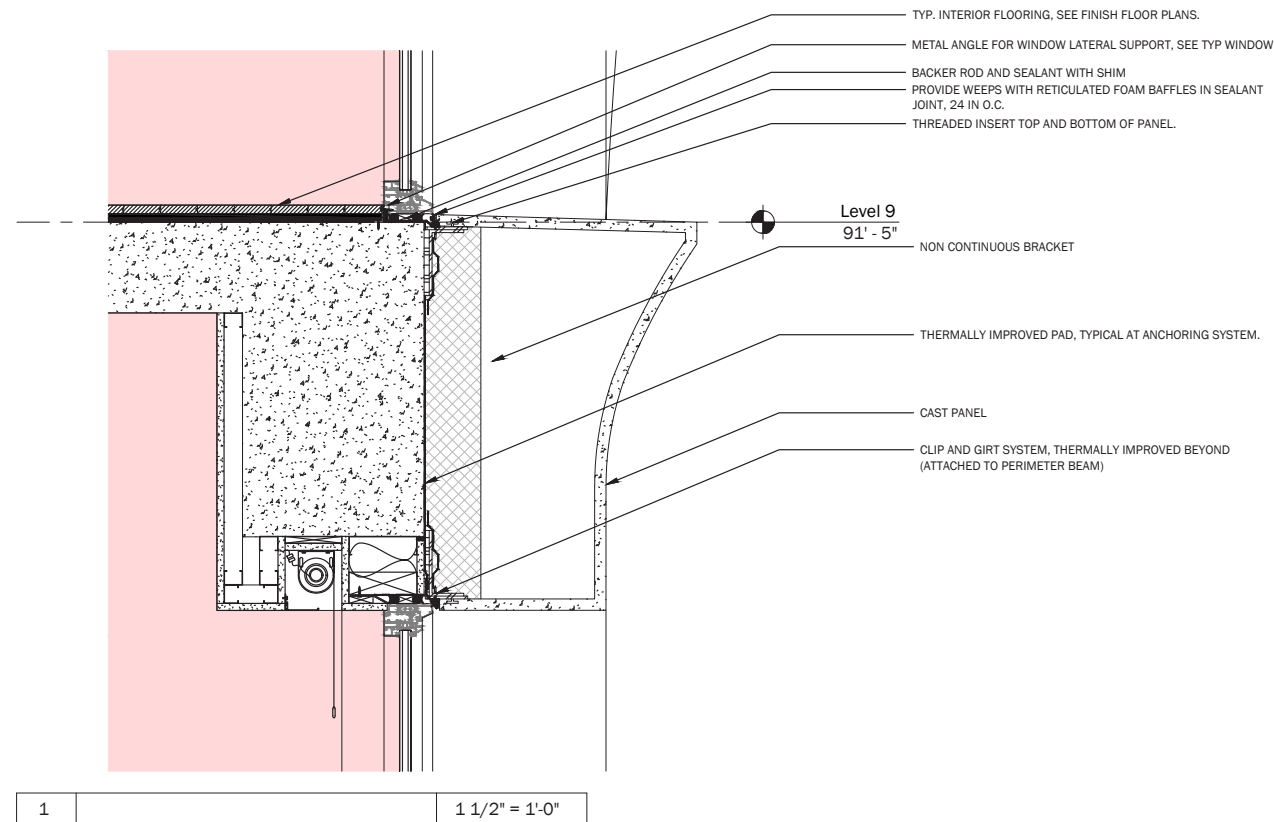

27 EAST 4TH STREET – WALL SECTIONS



DXA studio
© DXA studio
dxastudio.com

894 6th Avenue
5th Floor
NYC 10001
T 212 874 0567



GILSANZ MURRAY STEFICEK
Structural Engineers and Building Envelope Consultants

SCALE N/A
CLIENT N/A
PROJECT NUMBER 25.29
DATE FEB 11, 2026

41



EAST STREET VIEW - FROM E 4TH ST & BOWERY



KEY PLAN



A - EAST STREET VIEW - FROM E 4TH ST & BOWERY



B - WEST STREET VIEW - FROM E 4TH ST & LAFAYETTE



WEST STREET VIEW - FROM E 4TH ST & LAFAYETTE

27 EAST 4TH STREET — VISIBILITY STUDIES

SCALE N/A
 CLIENT
 PROJECT NUMBER 25.29
 DATE FEB 11, 2026



DXA studio
 © DXA studio
 dxastudio.com
 894 6th Avenue
 5th Floor
 NYC 10001
 T 212 874 0567





STRUCTURAL DESIGN



1960'S LOT LINE WALL CONDITION



CURRENT LOT LINE WALL CONDITION

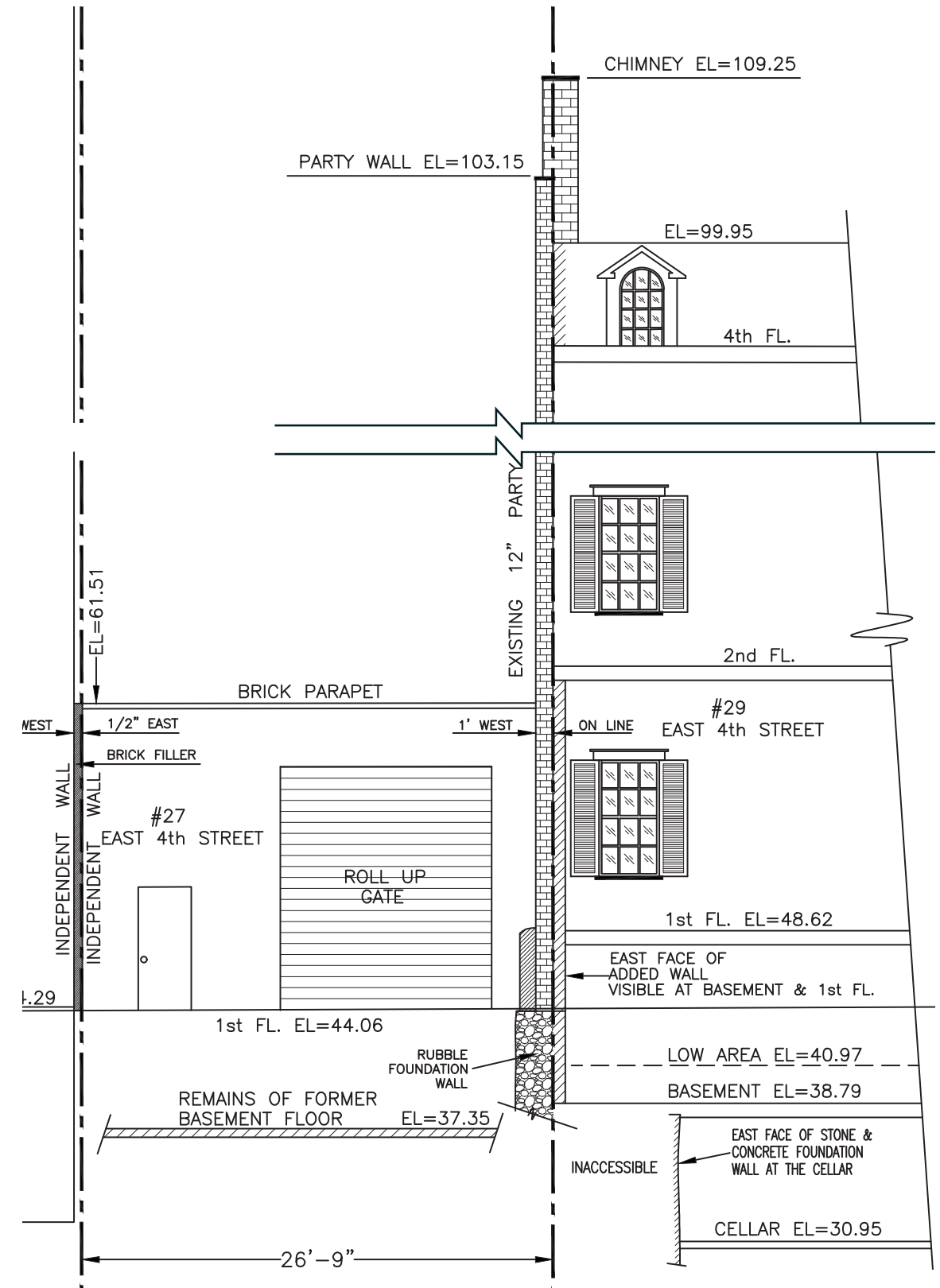

REVISED NEW NAVD 88 DATUM

27 EAST 4TH STREET – STRUCTURAL DESIGN: LOT LINE WALL SURVEY



DXA studio
 894 6th Avenue
 5th Floor
 NYC 10001
 T 212 874 0567
 © DXA studio
 dxastudio.com



GMS GILSANZ MURRAY STEFICEK
 Structural Engineers and Building Envelope Consultants

SCALE N/A
 CLIENT N/A
 PROJECT NUMBER 25.29
 DATE FEB 11, 2026



CURRENT LOT LINE WALL CONDITION

REVISED TO INCLUDE TEST PIT 1A

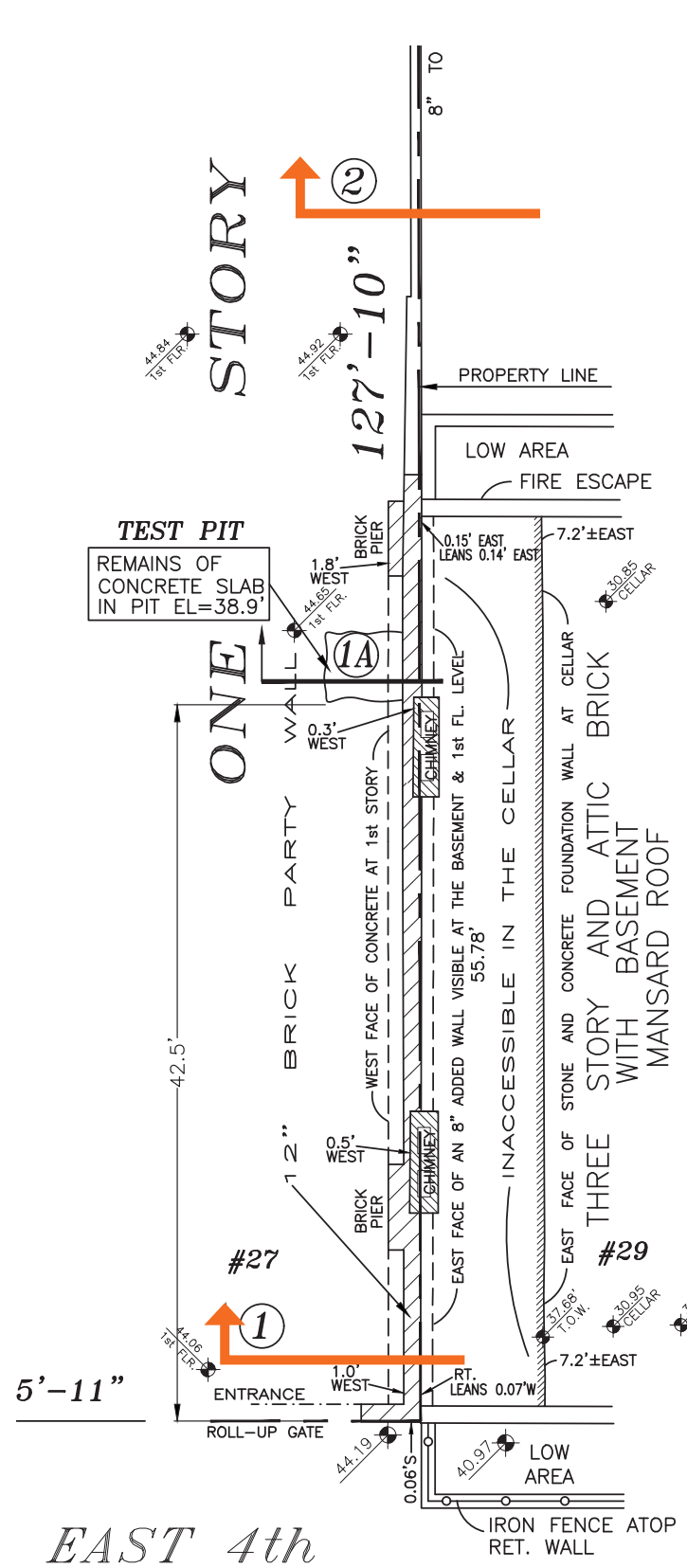

EAST 4th

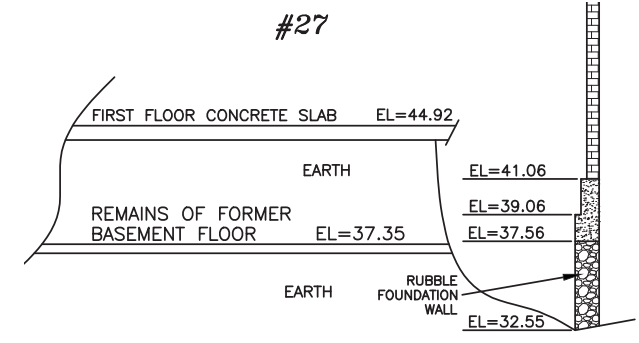

CROSS SECTION ②

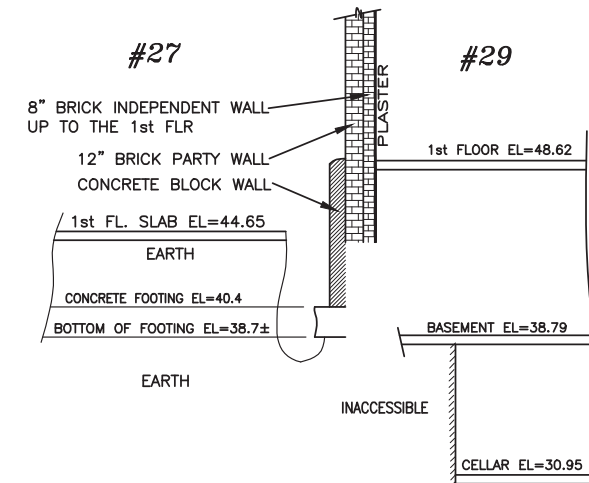

CROSS SECTION ①A

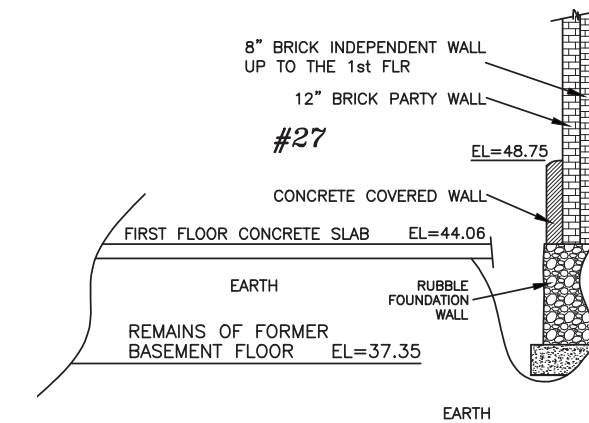

CROSS SECTION ①

27 EAST 4TH STREET – STRUCTURAL DESIGN: LOT LINE WALL TEST PITS



DXA studio
© DXA studio
dxastudio.com

894 6th Avenue
5th Floor
NYC 10001
T 212 874 0567



GILSANZ MURRAY STEFICEK
Structural Engineers and Building Envelope Consultants

SCALE N/A
CLIENT
PROJECT NUMBER 25.29
DATE FEB 11, 2026

January 18, 2023

Ariston Development
 78 Horatio St.
 New York, N 10014

Attn: Mr. Constantine Fotos

Re: Test pit observation report
 Proposed Building
 27 east 4th Street
 New York, NY
 GTC Job No.: ARTD322

Dear Mr. Fotos:

On November 29, 2022, our engineer visited the project site as per your request and inspected a recently excavated test pit.

The new test pit labeled as TP-4 was excavated along the east wall of the subject building at a location about 42.5' from the front wall of the same.

Our observation of the test pit was illustrated in sketches and presented on drawing G-001.01, which is attached at the end of this report. A brief description of the same is presented below.

In a cross section across the east wall, we observed a brick wall resting on a concrete wall that extended 9" below the top of the first-floor slab to rest on a concrete-rubble footing. The rubble footing was observed to extend to a depth around 6' below the top of the first floor to bear on natural sand soils. The natural sand soils were observed to consist of a mixture of coarse medium fine sands with trace to some silt consistent with the composition of the SM Group of the Unified Soil Classification System (USCS).

A horizontal probe was conducted along the underside of the rubble footing to detect adjacent wall or footings. Within the reach of 4' of the horizontal probing, no obstructions or concrete footings were detected or encountered (see test pit profile illustration).

As you are aware that the site was investigated in 2012 with three test pits (TP-1 thru TP-3). For your convenience I have attached the previous test pit finding drawing G-001.00 for your reference.

Review of drawings G-001.00 and G-001.01 suggests that TP-1 and TP-4 revealed similar findings in that the east wall footings at those two test pit locations bear on natural sand soils.

We trust the above information is sufficient for you review and use. Should you have any questions regarding this report, or if we can be of further assistance, please do not hesitate to contact us.

Respectfully Submitted
 Geo Tech Consultants LLC
 Steve J. J. Lin, P.E.

GEOTECHNICAL INVESTIGATION REPORT

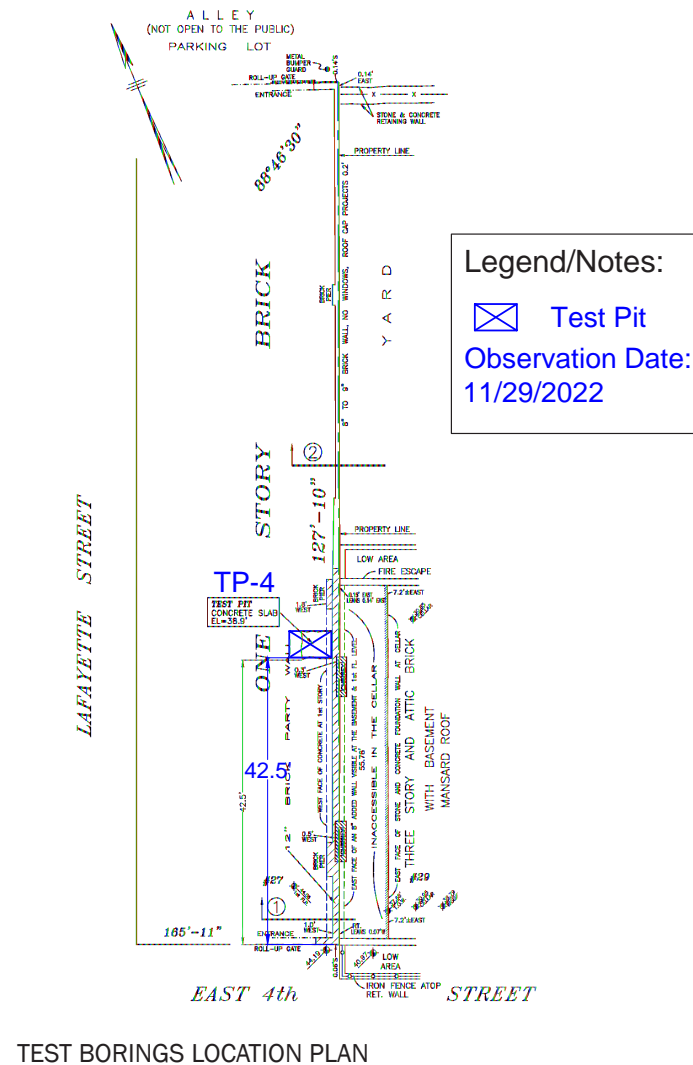

TEST BORINGS LOCATION PLAN

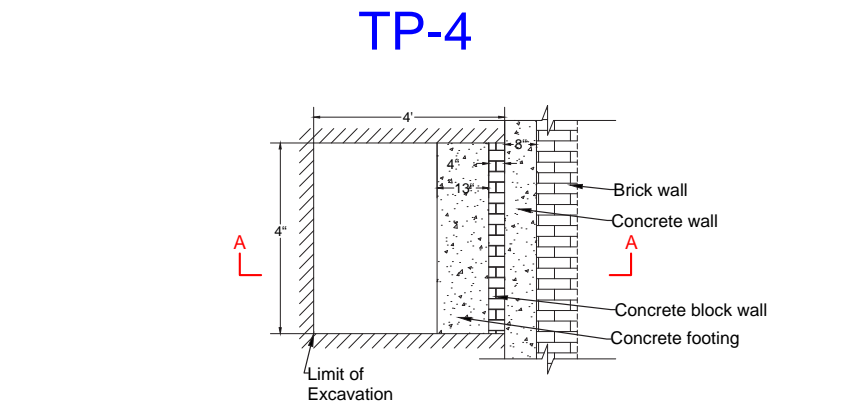

PLAN VIEW

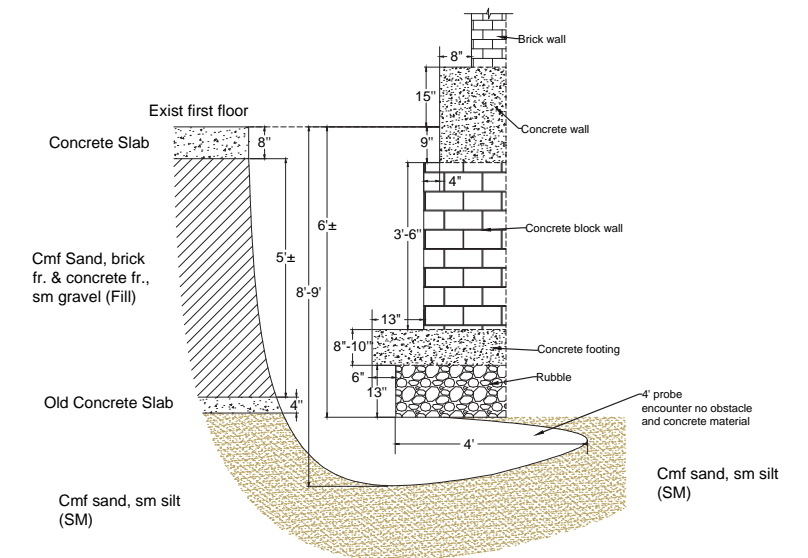

CROSS SECTION A-A

NEW TEST PIT: UNDISTURBED SOILS OF SIMILAR COMPOSITION TO EARLIER TEST PIT



PHOTO

27 EAST 4TH STREET — STRUCTURAL DESIGN: GEOTECHNICAL INVESTIGATION



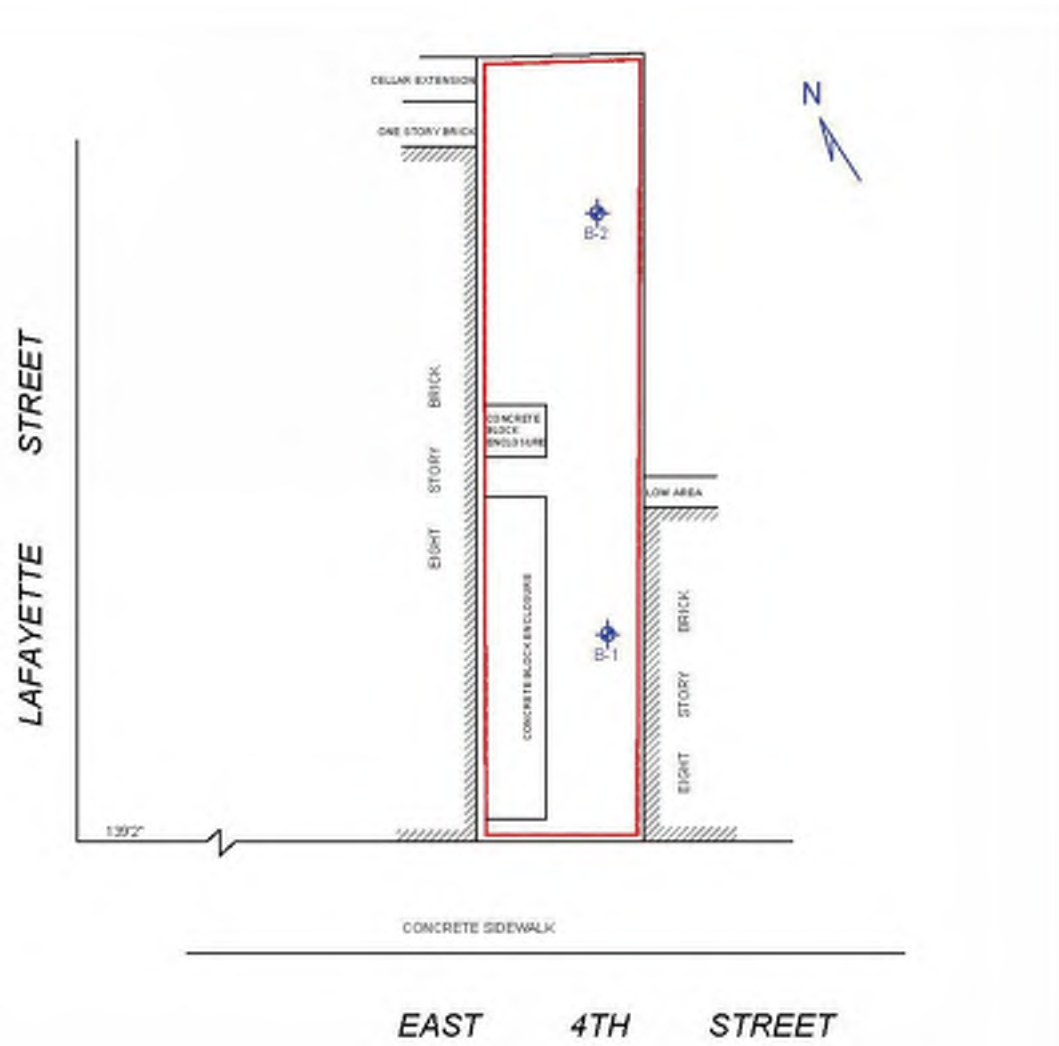

GEOTECHNICAL INVESTIGATION SITE PLAN

- GEOTECHNICAL INVESTIGATION PERFORMED.
- VOLUNTARY GEOTECHNICAL PEER REVIEW PERFORMED.
- SUBGRADE IS "GLACIATED SANDS CONSISTING OF MOSTLY COARSE-MEDIUM-FINE SANDS WITH TRACE TO SOME AMOUNT OF SILT AND/OR GRAVEL"
- USCS SP/SM, NYC CLASS 3B, "STIFF SOIL PROFILE"
- GROUNDWATER APPROX 40' BELOW GRADE
- SUBGRADE MODULUS 120 TCF FOR MAT DESIGN

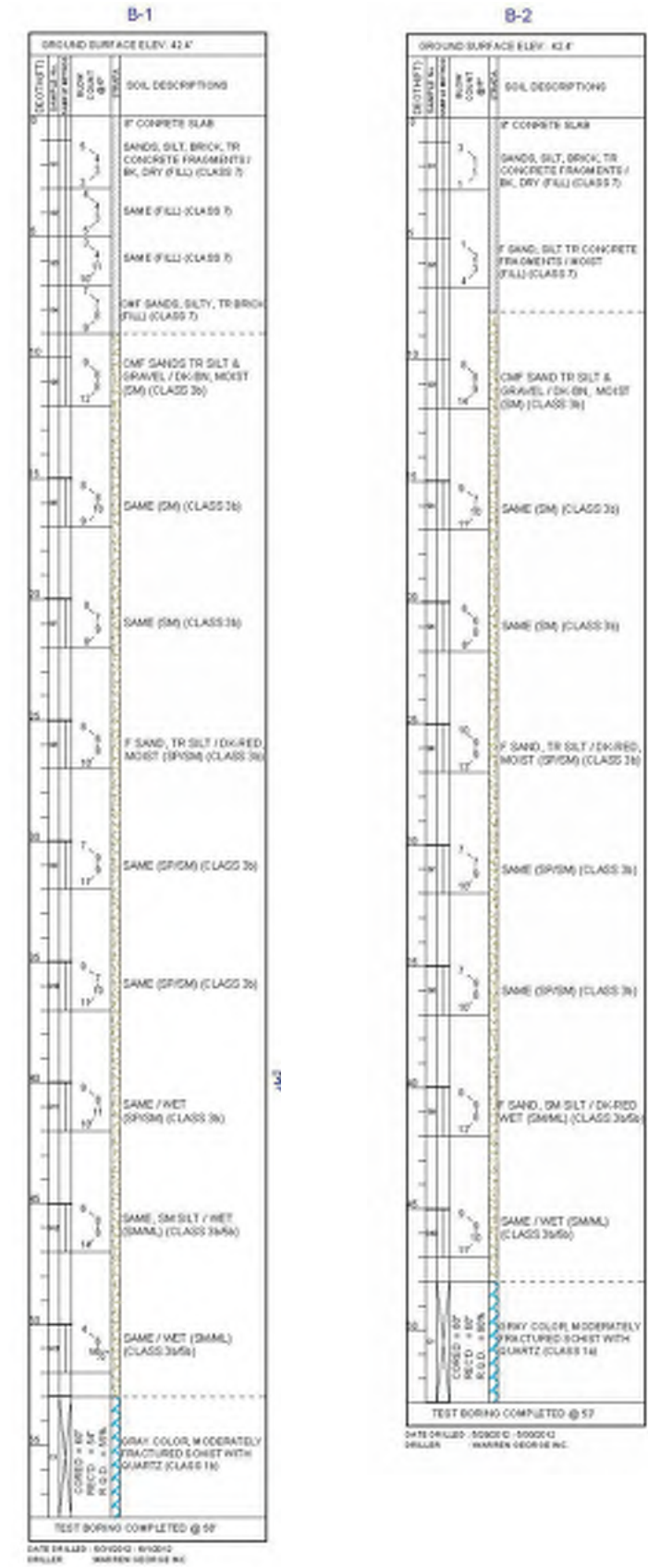

27 EAST 4TH STREET – **STRUCTURAL DESIGN: GEOTECHNICAL INVESTIGATION**



DXA studio
 894 6th Avenue
 5th Floor
 NYC 10001
 T 212 874 0567
 © DXA studio
 dxastudio.com



GMS GILSANZ MURRAY STEFICEK
 Structural Engineers and Building Envelope Consultants

SCALE N/A
 CLIENT
 PROJECT NUMBER 25.29
 DATE FEB 11, 2026

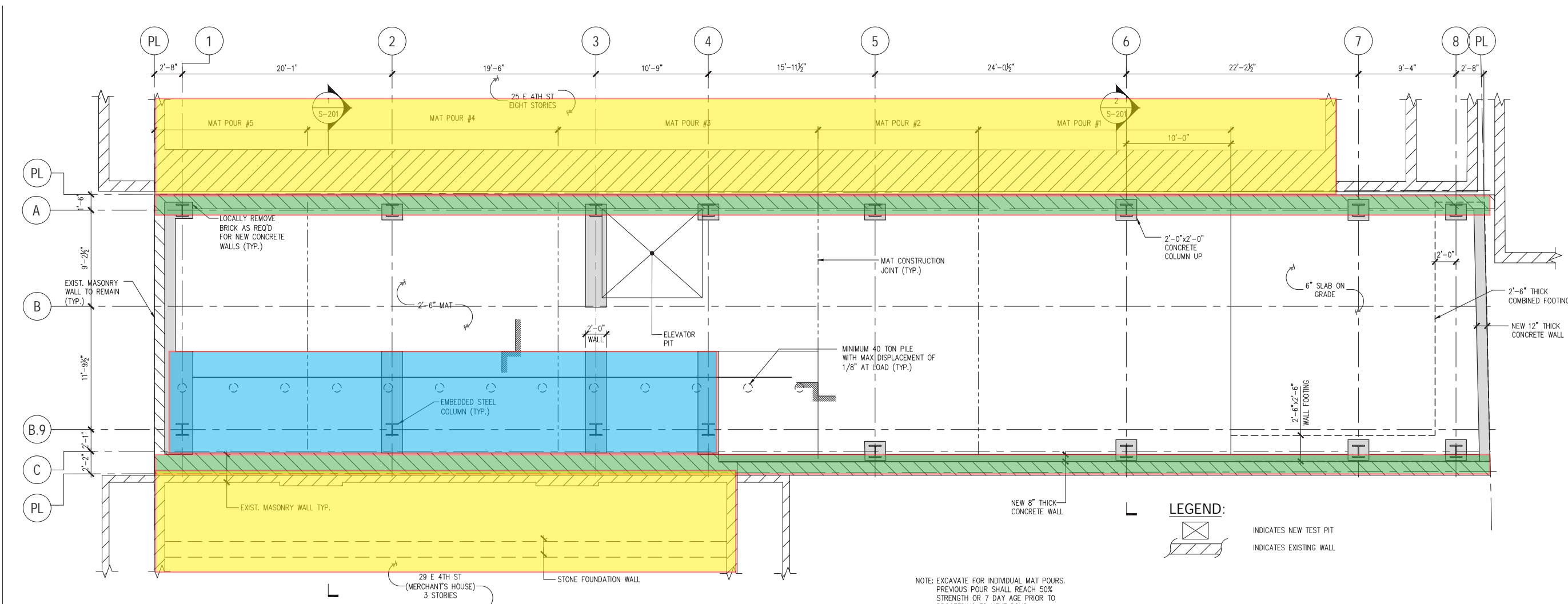

1 FOUNDATION PLAN
 FO-101 SCALE: 3/16"=1'-0"
 N

- REMOVE EXISTING ROOF AND FILLED CELLAR OF ONE STORY BUILDING AND REPLACE WITH NEW STEEL FRAMED BUILDING
 - EXISTING LOT LINE MASONRY WALLS TO REMAIN
 - STEP EXCAVATION TO AVOID UNDERPINNING EXISTING ADJACENT BUILDINGS
 - USE MAT FOUNDATION TO MINIMIZE SETTLEMENT AND MORE UNIFORMLY LOAD SOIL
-
- ANTICIPATED MAT SETTLEMENT <0.25"
 - NEW BUILDINGS WILL PROVIDE SHIELDING OF MERCHANT HOUSE
 - INTRODUCE PILES TO FURTHER LIMIT ANTICIPATED SETTLEMENT
 - COLUMN AND FOOTING LAYOUT REVISED TO MATCH CURRENT BUILDING MASSING

27 EAST 4TH STREET — STRUCTURAL DESIGN: SOE & CONSTRUCTION SEQUENCE



DXA studio
 © DXA studio
 dxastudio.com
 894 6th Avenue
 5th Floor
 NYC 10001
 T 212 874 0567



SCALE N/A
 CLIENT N/A
 PROJECT NUMBER 25.29
 DATE FEB 11, 2026

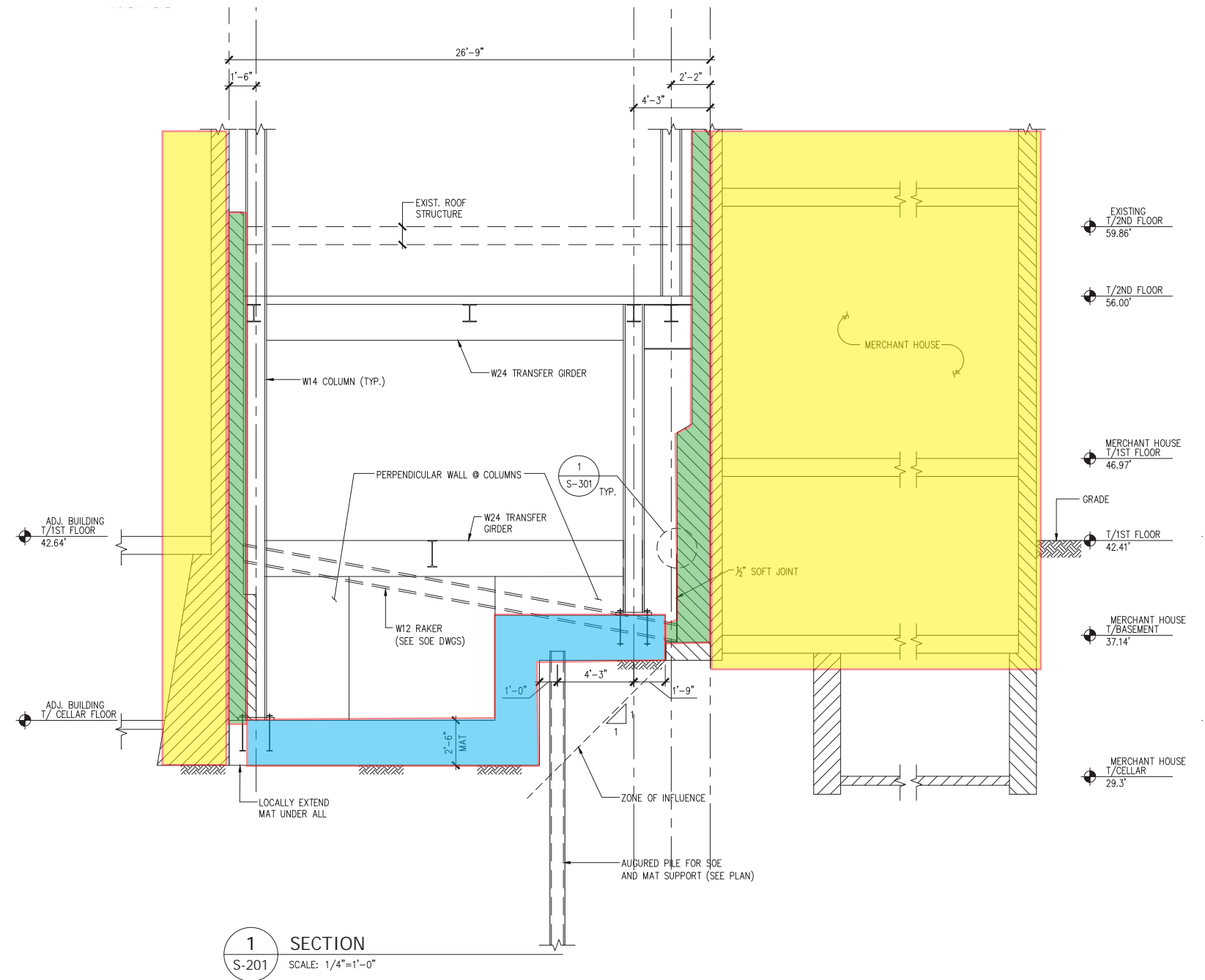

1 SECTION
S-201 SCALE: 1/4"=1'-0"

- STEEL COLUMNS SUPPORTING NEW BUILDING PULLED BACK FROM EXISTING MASONRY LOT LINE WALL AT MH.
- STEPPED MAT FOUNDATION USED TO MINIMIZE EXCAVATION AND SETTLEMENT.
- PILES TO PROVIDE SUPPORT OF EXCAVATION AND ADDITIONAL SUPPORT TO MAT ADJACENT TO MERCHANT HOUSE MUSEUM

27 EAST 4TH STREET — **STRUCTURAL DESIGN: SOE & CONSTRUCTION SEQUENCE**



DXA studio
© DXA studio
dxastudio.com
894 6th Avenue
5th Floor
NYC 10001
T 212 874 0567



GMS GILSANZ MURRAY STEFICEK
Structural Engineers and Building Envelope Consultants

SCALE N/A
CLIENT N/A
PROJECT NUMBER 25.29
DATE FEB 11, 2026

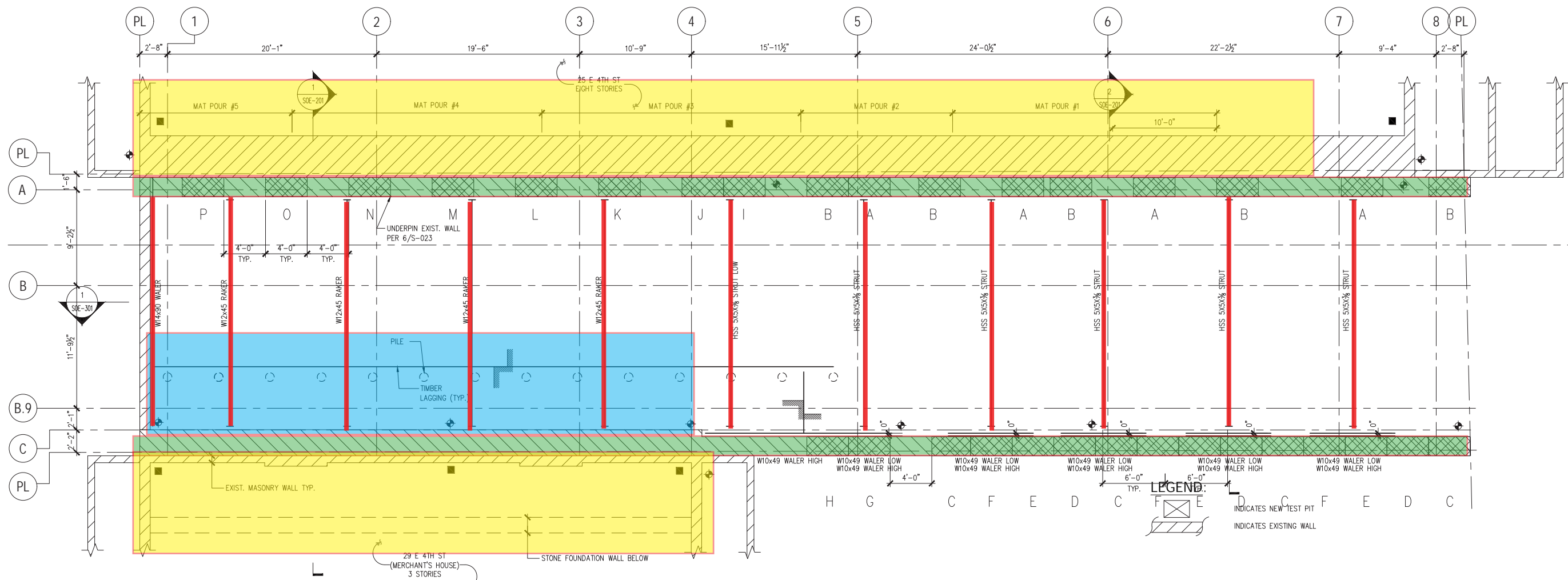

1 SUPPORT OF EXCAVATION PLAN
 SOE-100 SCALE: 3/16"=1'-0"

- SUPPORT OF EXCAVATION AND CONSTRUCTION FOLLOW A CONTROLLED SEQUENCE THAT MAINTAINS LATERAL BRACING OF MERCHANT HOUSE.
- SHELVED EXCAVATION ADJACENT TO MERCHANT HOUSE STABILIZED WITH AUGERED PILES.
- ROOF OF EXISTING ONE STORY BUILDING WILL REMAIN IN PLACE TO PROTECT EXCAVATION AND BRACE MERCHANT HOUSE.

27 EAST 4TH STREET – STRUCTURAL DESIGN: SOE & CONSTRUCTION SEQUENCE



DXA studio
 © DXA studio
 dxastudio.com

894 6th Avenue
 5th Floor
 NYC 10001
 T 212 874 0567



SCALE N/A
 CLIENT
 PROJECT NUMBER 25.29
 DATE FEB 11, 2026

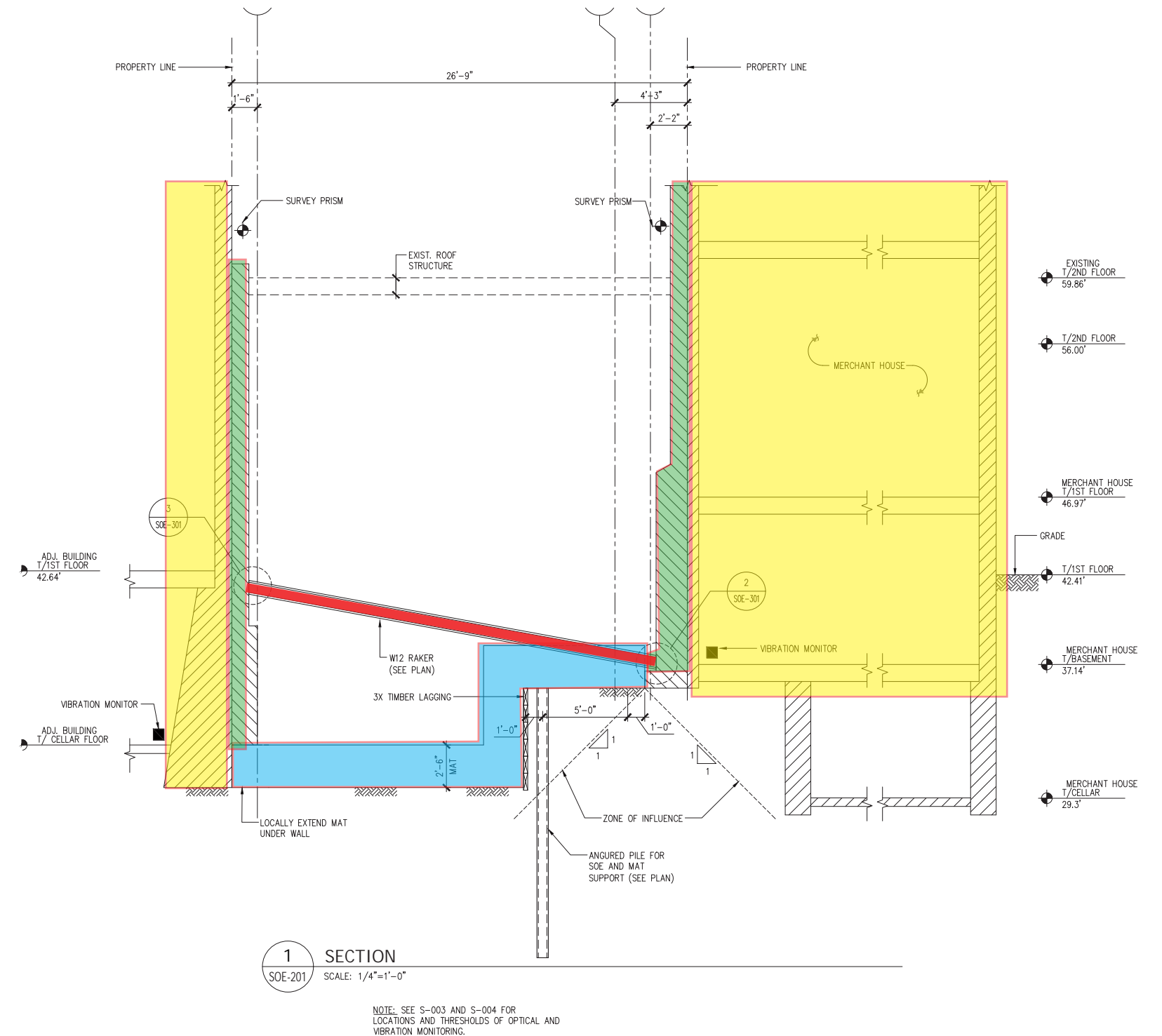

SUPPORT OF EXCAVATION SECTION

GENERAL SEQUENCE ADJACENT TO MERCHANT'S HOUSE:

1. REMOVE EXIST PARTITIONS AND SLAB ON GRADE.
2. INSTALL AUGERED PILES APPROX 7' FROM EXIST FOUNDATION.
3. REMOVE EXIST FILL/DEBRIS DOWN TO APPROX ORIGINAL CELLAR FLOOR.
4. INSTALL BRACES.
5. EXCAVATE TO SUBGRADE LEVEL FOR MAT, INSTALLING LAGGING AS EXCAVATION PROGRESSES.
6. INSTALL UNDERPINNING AT 27 E 4TH WESTERN LOT LINE WALL.
7. INSTALL MAT FOUNDATION.
8. INSTALL NEW BUILDING UP TO 2ND FLOOR.
9. REMOVE EXIST ROOF AND THEN INSTALL REMAINDER OF NEW BUILDING.

27 EAST 4TH STREET – STRUCTURAL DESIGN: SOE & CONSTRUCTION SEQUENCE



DXA studio
 894 6th Avenue
 5th Floor
 NYC 10001
 T 212 874 0567
 © DXA studio
 dxastudio.com



GMS GILSANZ MURRAY STEFICEK
 Structural Engineers and Building Envelope Consultants

SCALE N/A
 CLIENT N/A
 PROJECT NUMBER 25.29
 DATE FEB 11, 2026

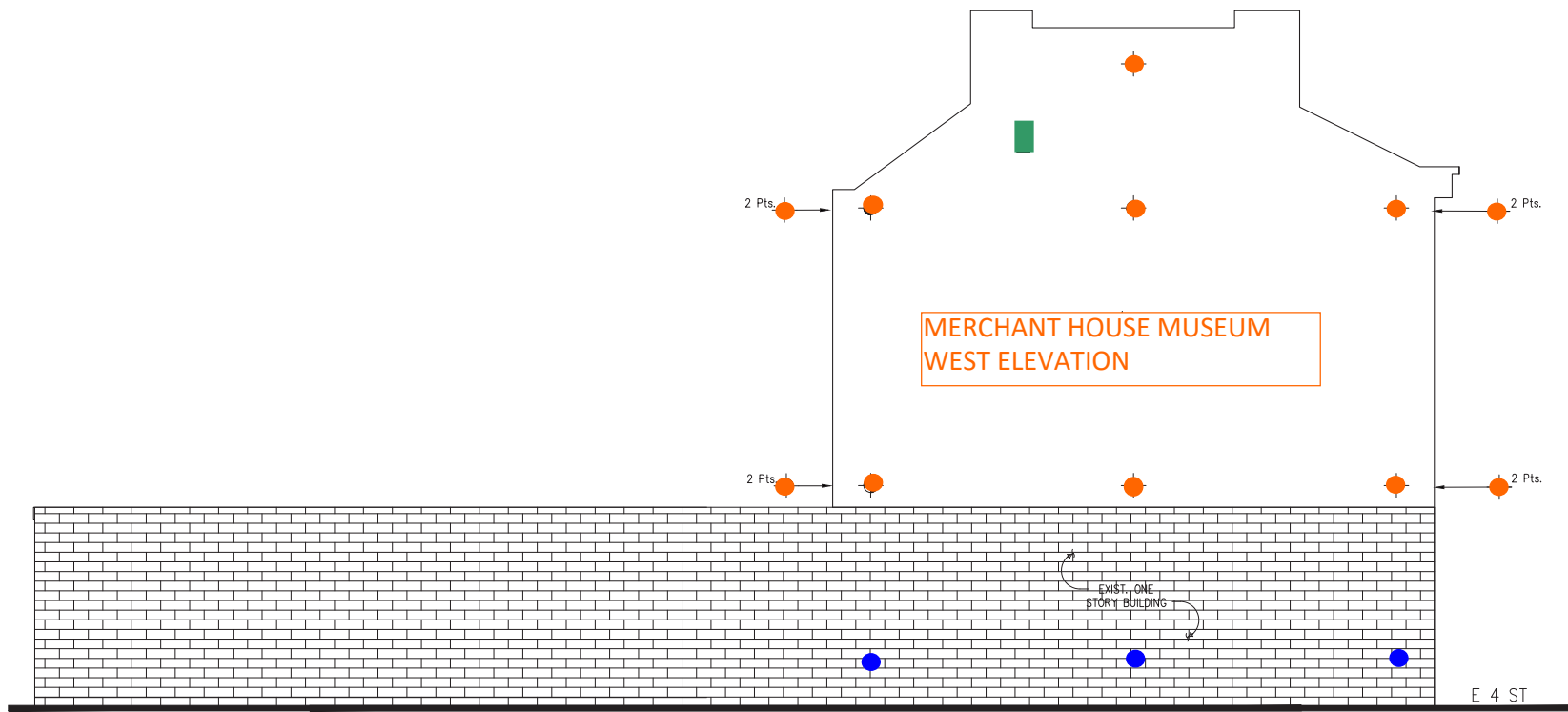

1 WEST SURVEY ELEVATION
SCALE: 1/8"=1'-0"

LEGEND:

- SURVEY POINTS TO BE MONITORED DURING CONSTRUCTION FOR MOVEMENT
- BIAXIAL TILTMETER
- VIBRATION MONITOR

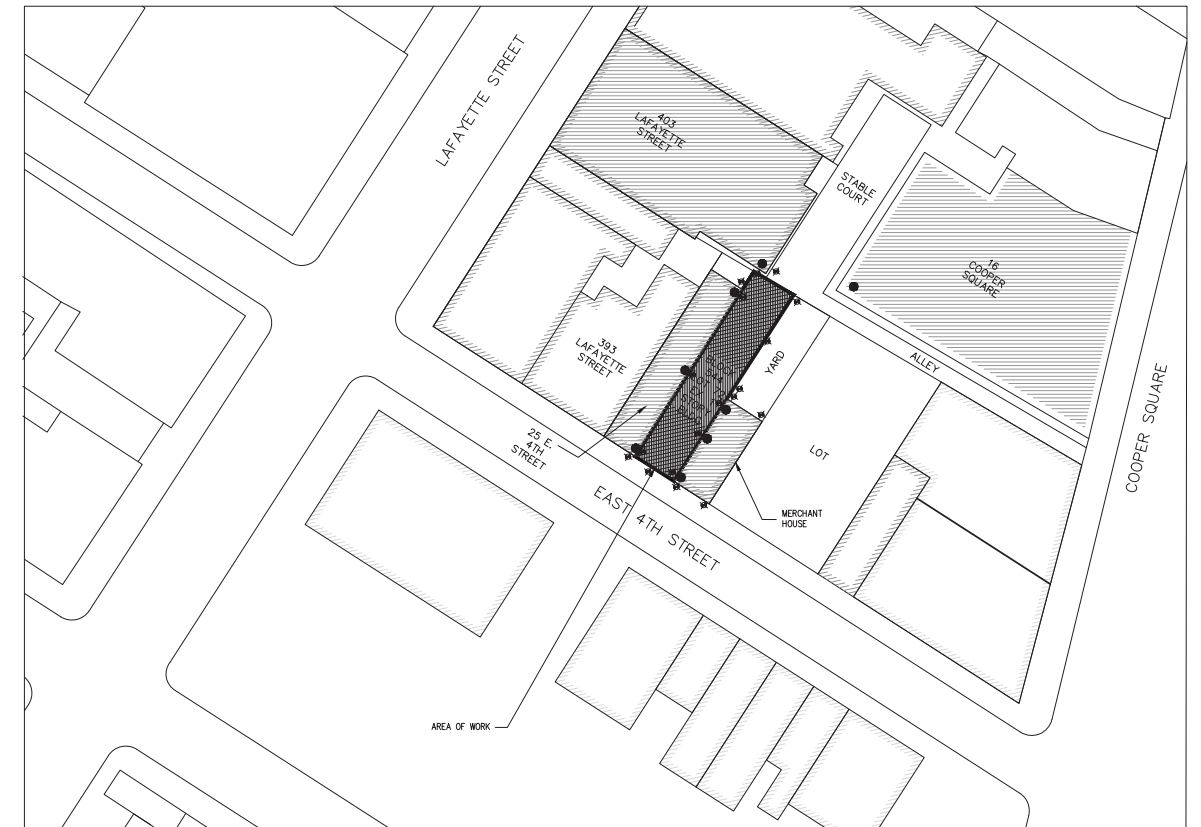

2 VIBRATION MONITORING PLAN
N.T.S.

LEGEND:

- CONSTRUCTION AREA
- BUILDING TO BE MONITORED FOR VIBRATION
- PLANNED LOCATION OF VIBRATION MONITORS LOCATED IN BUILDING CELLARS OR MOUNTED TO EXTERIOR FACE OF MASONRY WALL AT GROUND FLOOR
- ⊕ LOCATION OF SURVEY PRISM AT 2ND FLOOR AND TOP OF BUILDING (NATURAL TARGETS PERMITTED-EXCLUDING MERCHANT HOUSE)

27 EAST 4TH STREET – STRUCTURAL DESIGN: MONITORING AND PROTECTION



DXA studio
894 6th Avenue
5th Floor
NYC 10001
T 212 874 0567
© DXA studio
dxastudio.com



GMS GILSANZ MURRAY STEFICEK
Structural Engineers and Building Envelope Consultants

SCALE N/A
CLIENT N/A
PROJECT NUMBER 25.29
DATE FEB 11, 2026

MONITORING TASK	MINIMUM REQUIRED BY TPPN 10/88	PROPOSED FOR MERCHANT HOUSE MUSEUM	PROPOSED FOR ALL OTHER ADJACENT LANDMARK BUILDINGS (25 E. 4th Street, 403 Lafayette Street, 16 Cooper Square)
DISPLACEMENT MONITORING	SURVEY MEASUREMENTS MADE TWICE A WEEK TO AN ACCURACY OF ±0.01 FT. MAXIMUM ALLOWED VERTICAL AND HORIZONTAL DISPLACEMENT ¼ IN.	SURVEY MEASUREMENTS MADE TWICE A WEEK TO AN ACCURACY OF ±0.05 FT. DURING DEMOLITION AND EXCAVATION, CONTINUOUS AUTOMATIC SURVEY TO AN ACCURACY OF ±0.05 FT. MAXIMUM ALLOWED VERTICAL AND HORIZONTAL DISPLACEMENT ¼ IN. NOTIFICATION AND REVIEW THRESHOLD ⅛ IN.	SURVEY MEASUREMENTS MADE TWICE A WEEK TO AN ACCURACY OF ±0.01 FT. MAXIMUM ALLOWED VERTICAL AND HORIZONTAL DISPLACEMENT ¼ IN.
CRACK MONITORING	"TELLTALES" INSTALLED ACROSS EXISTING CRACKS IN MASONRY MEASURED ONCE DAILY W/MICROMETER SENSITIVE TO 0.001 IN. PHOTOGRAPHS TO BE TAKEN WEEKLY.	"TELLTALES" INSTALLED ACROSS EXISTING CRACKS IN MASONRY MEASURED ONCE DAILY W/MICROMETER SENSITIVE TO 0.001 IN. PHOTOGRAPHS TO BE TAKEN WEEKLY.	"TELLTALES" INSTALLED ACROSS EXISTING CRACKS IN MASONRY MEASURED ONCE DAILY W/MICROMETER SENSITIVE TO 0.001 IN. PHOTOGRAPHS TO BE TAKEN WEEKLY.
TILT MONITORING	NONE.	NOTIFICATION AND REVIEW THRESHOLD: 0.001 RAD.	N/A
VIBRATION MONITORING	MAXIMUM ALLOWED PEAK PARTICLE VELOCITY: 0.5 IN/S	NOTIFICATION AND REVIEW THRESHOLD: 0.2 IN/S MAXIMUM ALLOWED PEAK PARTICLE VELOCITY : 0.5 IN/S	MAXIMUM ALLOWED PEAK PARTICLE VELOCITY : 0.5 IN/S

MERCHANT HOUSE ACTION PLAN DURING CONSTRUCTION

1. DISPLACEMENT, CRACK, TILT AND VIBRATION MONITORING IN ACCORDANCE WITH ADJACENT CRITERIA.
2. IN THE EVENT THAT NOTIFICATION AND REVIEW THRESHOLDS ARE REACHED:
 - A. THE CLIENT-DESIGNATED PARTIES, IE CONTRACTOR, OWNER, ENGINEER, AND ADJACENT PROPERTY OWNER, SHALL BE NOTIFIED VIA EMAIL IMMEDIATELY.
 - B. THE CONTRACTOR SHALL PROVIDE A WRITTEN EXPLANATION OF THE ACTIONS WHICH CAUSED THE VIBRATION OR MOVEMENT, AND IDENTIFY STEPS BEING TAKEN TO MINIMIZE FUTURE VIBRATION OR MOVEMENT.
 - C. THE ENGINEER SHALL REVIEW THE DATA AND MAKE RECOMMENDATIONS AS RELEVANT.
3. IN THE EVENT THAT MAXIMUM VIBRATION OR DISPLACEMENT CRITERIA ARE EXCEEDED:
 - A. CONTRACTOR SHALL CEASE CONSTRUCTION ACTIVITIES AND CONSULT WITH ENGINEER OF RECORD. ADJACENT PROPERTY OWNER AND DEPARTMENT OF BUILDINGS SHALL BE NOTIFIED IMMEDIATELY.
 - B. ENGINEER OF RECORD TO REVIEW DATA AND OBSERVE/DOCUMENT ADJACENT STRUCTURES FOR SIGNS OF DISTRESS. ANY SIGNS OF DISTRESS TO BE BROUGHT TO THE ATTENTION OF THE ADJACENT STRUCTURES OWNER.
 - C. IF SIGNIFICANT SIGNS OF DISTRESS ARE FOUND AND/OR MOVEMENT BEYOND 1/4" NOTED WORK SHALL NOT PROCEED UNTIL THE CAUSE OF THE DISTRESS/MOVEMENT IS IDENTIFIED AND STEPS ARE TAKEN TO PREVENT ADDITIONAL DISTRESS OR MOVEMENT. ANY STRUCTURAL DAMAGE SHALL BE REPAIRED PRIOR TO WORK PROCEEDING.
 - D. IF NO SIGNS OF DISTRESS ARE FOUND AND/OR MOVEMENT DOES NOT EXCEED 1/4" WORK MAY PROCEED, BUT EQUIPMENT OR METHOD BEING USED SHALL BE ALTERED OR TERMINATED TO PREVENT VIBRATION AND/OR DISPLACEMENT CRITERIA FROM BEING EXCEEDED.

MONITORING PLAN CHART

MONITORING PROGRAM MEETS OR EXCEEDS TPPN 10-88

- SETTLEMENT MONITORING COMPLETED BY AUTOMATIC TOTAL STATION WITH REALTIME REPORTING IN LIEU OF BI-WEEKLY
- ADDITIONAL VIBRATION REVIEW THRESHOLD OF 0.2 IN/S HELPS ANTICIPATE HIGHER VIBRATION
- BASELINE MONITORING COMPLETE JUNE-OCTOBER 2012 HAD 5 VIBRATION EVENTS ABOVE 0.5 IN/S. HIGHEST OF 0.622 IN/S
- ADDITIONAL MOVEMENT REVIEW THRESHOLD OF 1/8"
- REPEAT VIBRATION MONITORING 2 MONTHS PRIOR TO CONSTRUCTION

27 EAST 4TH STREET – STRUCTURAL DESIGN: MONITORING AND PROTECTION



DXA studio
 894 6th Avenue
 5th Floor
 NYC 10001
 T 212 874 0567
 © DXA studio
 dxastudio.com



GILSANZ MURRAY STEFICEK
 Structural Engineers and Building Envelope Consultants

SCALE N/A
 CLIENT N/A
 PROJECT NUMBER 25.29
 DATE FEB 11, 2026

NW

**APPENDIX:
ZONING, PLANS,
ELEVATIONS, &
SECTIONS**

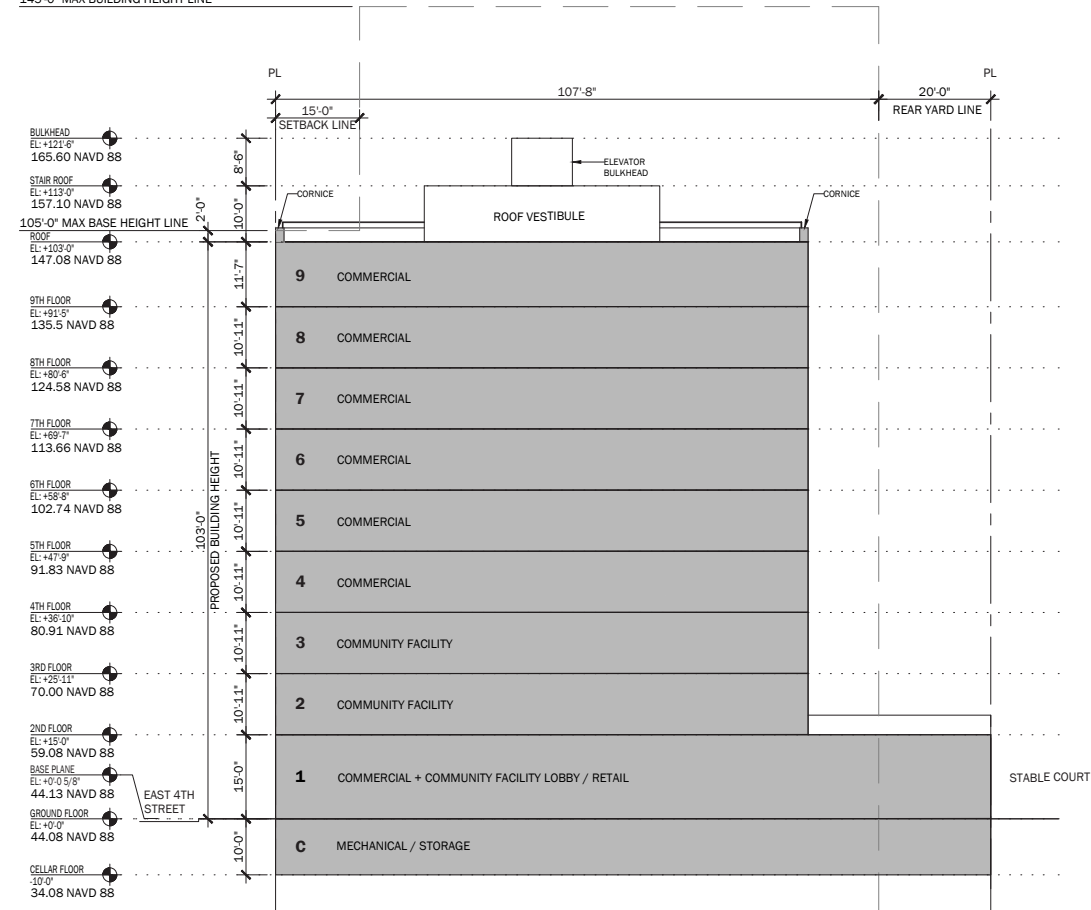

1 ZONING SECTION 1/16"=1'-0"

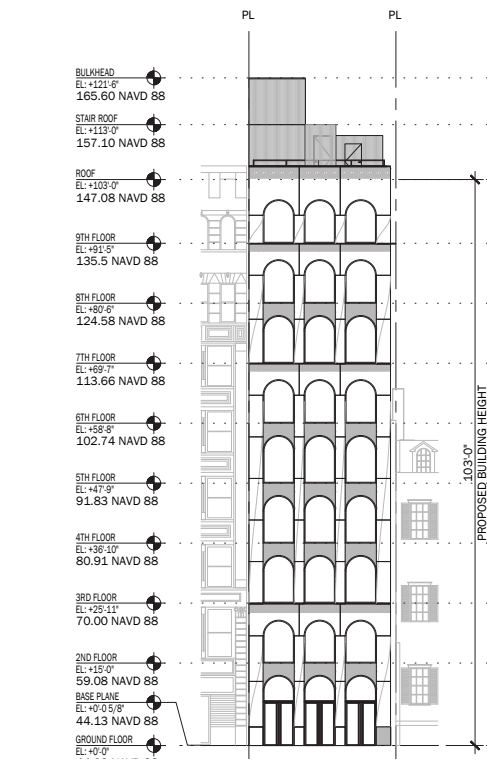

3 ZONING ELEVATION 1/16"=1'-0"

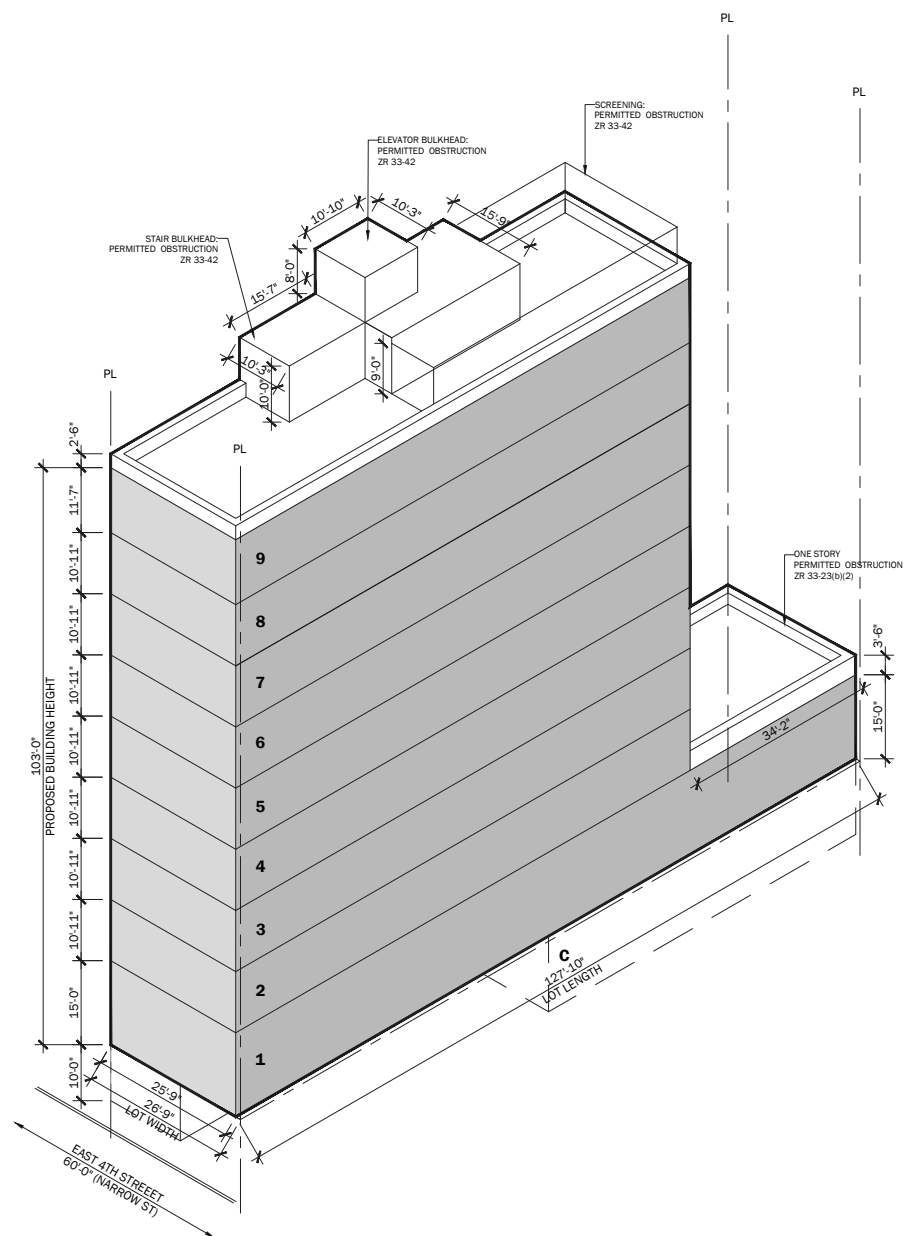

2 ZONING AXONOMETRIC NTS

EXISTING FLOOR AREA	3,600
ZONING DISTRICT	M1-S17X/SN1
TANDMARKS	NONE
DESIGNATION	E-319
FLOOD ZONE	X
EXCLUSORY HOUSING	MH

NO.	SECTION	REQUIREMENT	COMPLIANCE
4	143-23 (b)	MAXIMUM BUILDING HEIGHT: 103'-0"	COMPLIES
4	21	STANDARD SETBACK REGULATIONS WITH EAST 11' SHALL BE PROVIDED (SEE ZONING MAP)	COMPLIES
13-10		REQUIREMENT N/A	COMPLIES
36-1144-80		REQUIREMENT N/A	COMPLIES
36-4124 (b)		REQUIREMENT N/A	COMPLIES
32-381		REQUIREMENT N/A	COMPLIES

27 EAST 4TH STREET – ZONING ANALYSIS & DIAGRAMS



DXA studio
 894 6th Avenue
 5th Floor
 NYC 10001
 T 212 874 0567
 © DXA studio
 dxastudio.com



GMS GILSANZ MURRAY STEFICEK
 Structural Engineers and Building Envelope Consultants

SCALE N/A
 CLIENT N/A
 PROJECT NUMBER 25.29
 DATE FEB 11, 2026

LAFAYETTE STREET
(100' WIDE STREET)

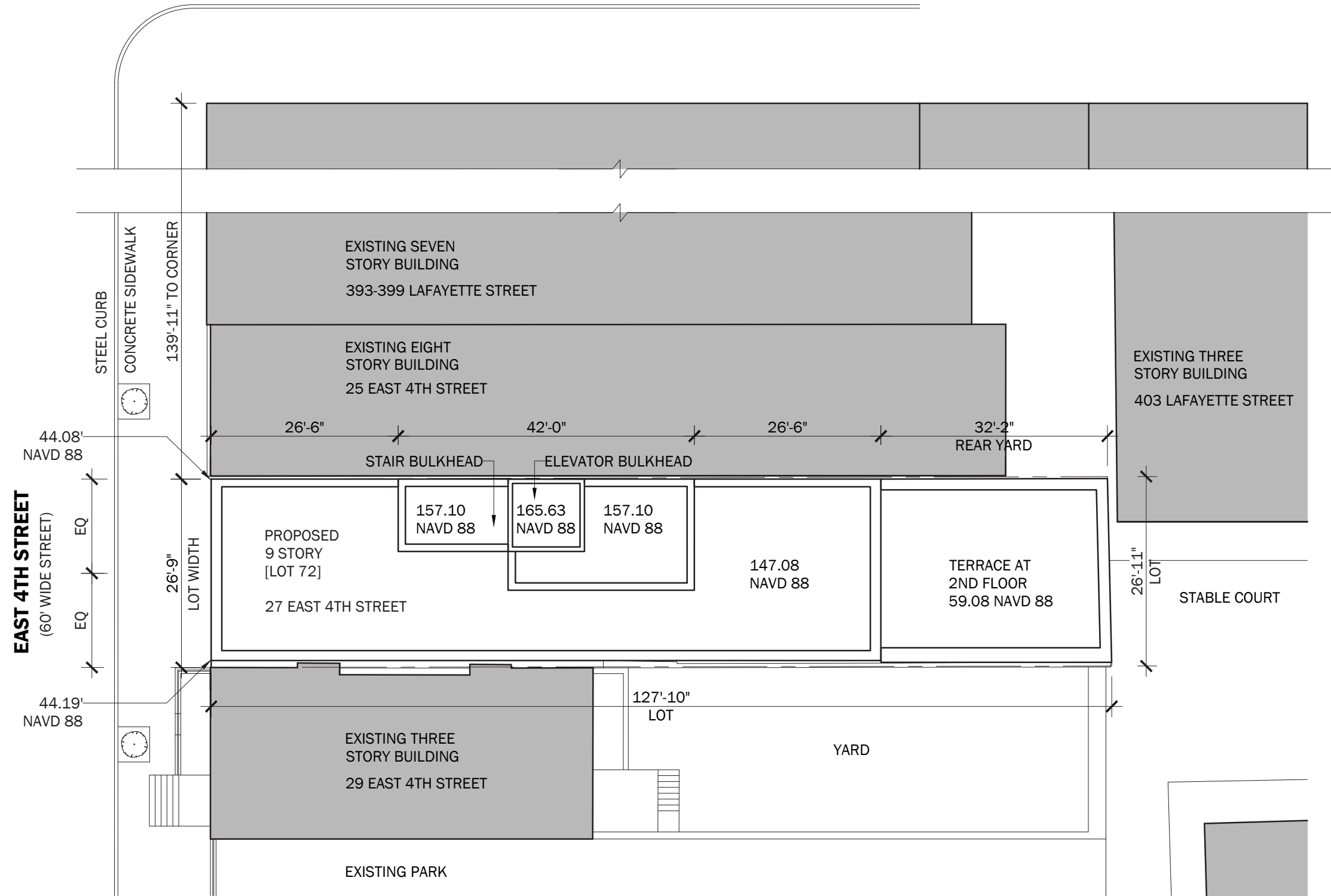

27 EAST 4TH STREET — PROPOSED SITE PLAN

SCALE N/A
 CLIENT N/A
 PROJECT NUMBER 25.29
 DATE FEB 11, 2026



DXA studio
 © DXA studio
 dxastudio.com
 894 6th Avenue
 5th Floor
 NYC 10001
 T 212 874 0567



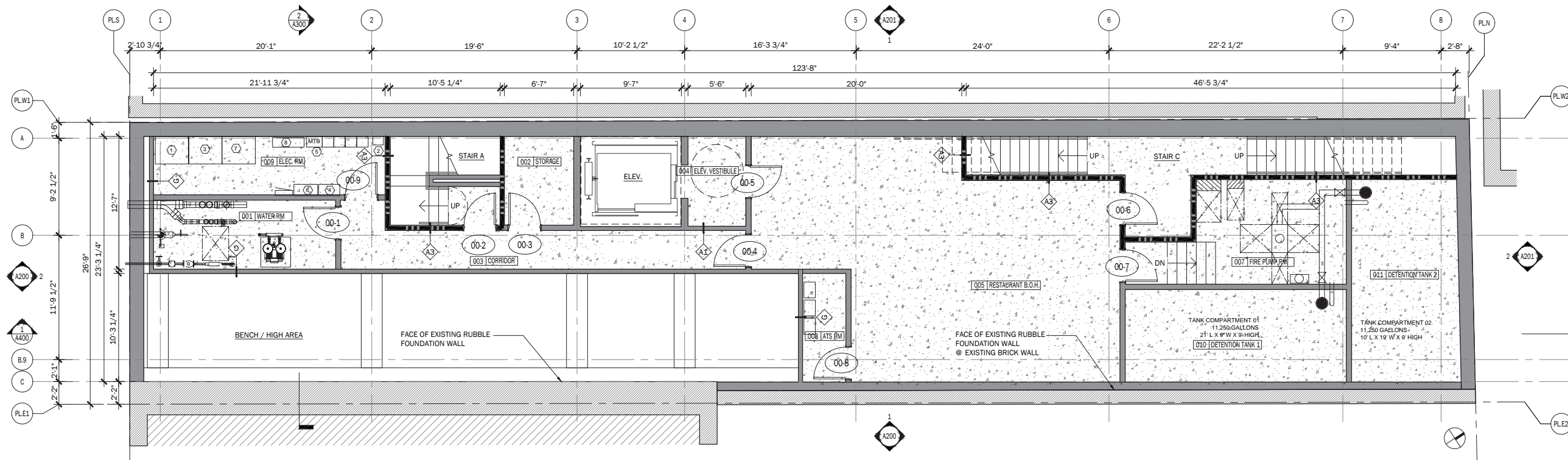

1 CELLAR PROPOSED PLAN 3/16"=1'-0"

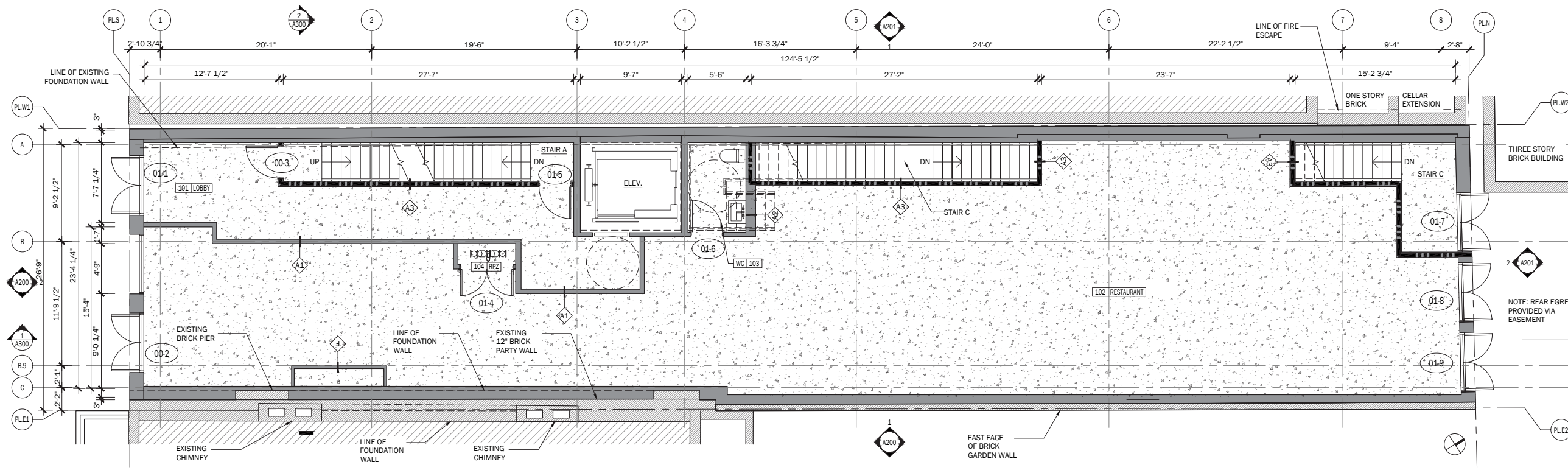

2 GROUND FLOOR PROPOSED PLAN 3/16"=1'-0"

27 EAST 4TH STREET — PROPOSED CELLAR & GROUND FLOOR PLANS



DXA studio
 894 6th Avenue
 5th Floor
 NYC 10001
 T 212 874 0567
 © DXA studio
 dxastudio.com



SCALE N/A
 CLIENT
 PROJECT NUMBER 25.29
 DATE FEB 11, 2026

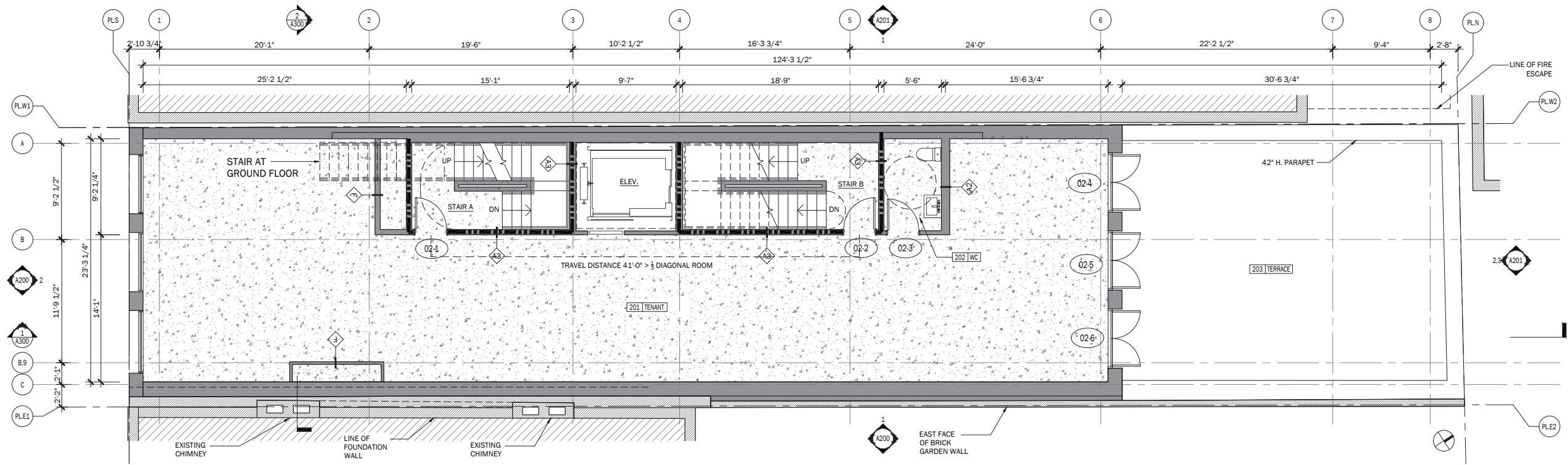

1 SECOND FLOOR PLAN 3/16"=1'-0"

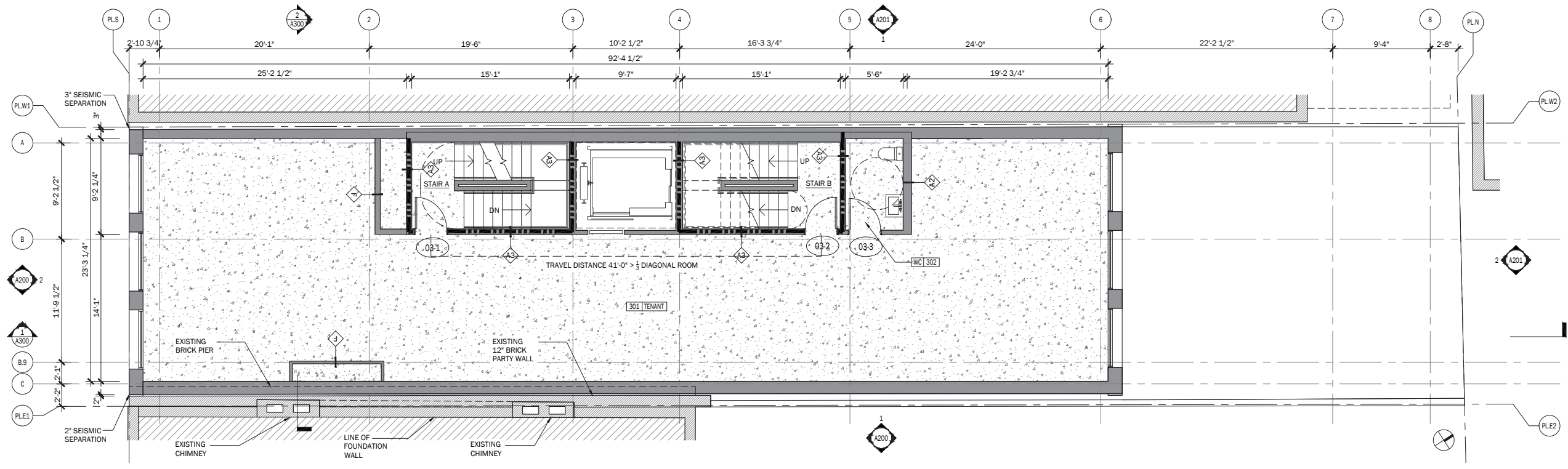

2 FLOORS 3-9 TYPICAL FLOOR PLANS 3/16"=1'-0"

27 EAST 4TH STREET – PROPOSED SECOND & TYPICAL FLOOR PLANS



DXA studio
 894 6th Avenue
 5th Floor
 NYC 10001
 T 212 874 0567
 © DXA studio
 dxastudio.com



SCALE N/A
 CLIENT N/A
 PROJECT NUMBER 25.29
 DATE FEB 11, 2026

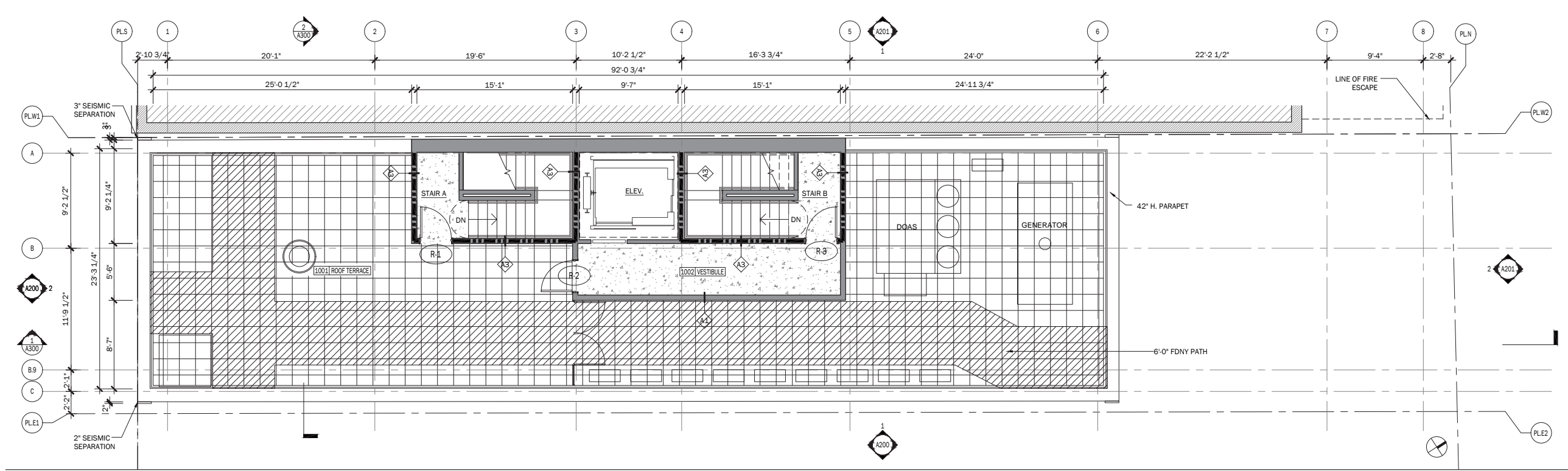

1 ROOF PLAN 3/16"=1'-0"

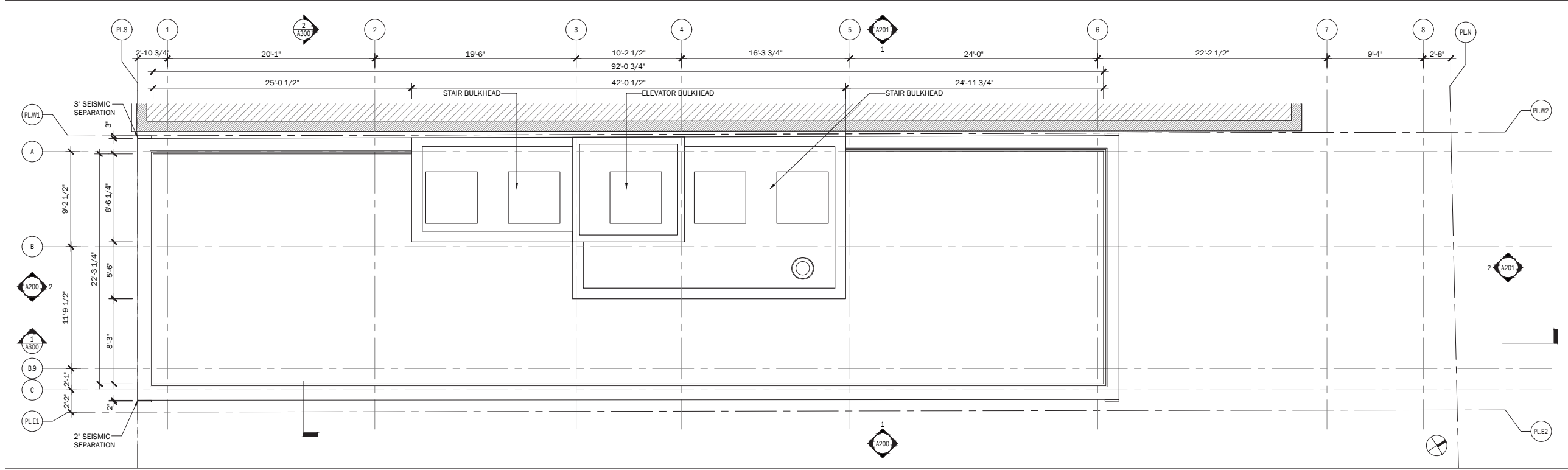

2 BULKHEAD PLAN 3/16"=1'-0"

27 EAST 4TH STREET – PROPOSED ROOF & BULKHEAD FLOOR PLANS



DXA studio
 894 6th Avenue
 5th Floor
 NYC 10001
 T 212 874 0567
 © DXA studio
 dxastudio.com



GMS GILSANZ MURRAY STEFICEK
 Structural Engineers and Building Envelope Consultants

SCALE N/A
 CLIENT N/A
 PROJECT NUMBER 25.29
 DATE FEB 11, 2026

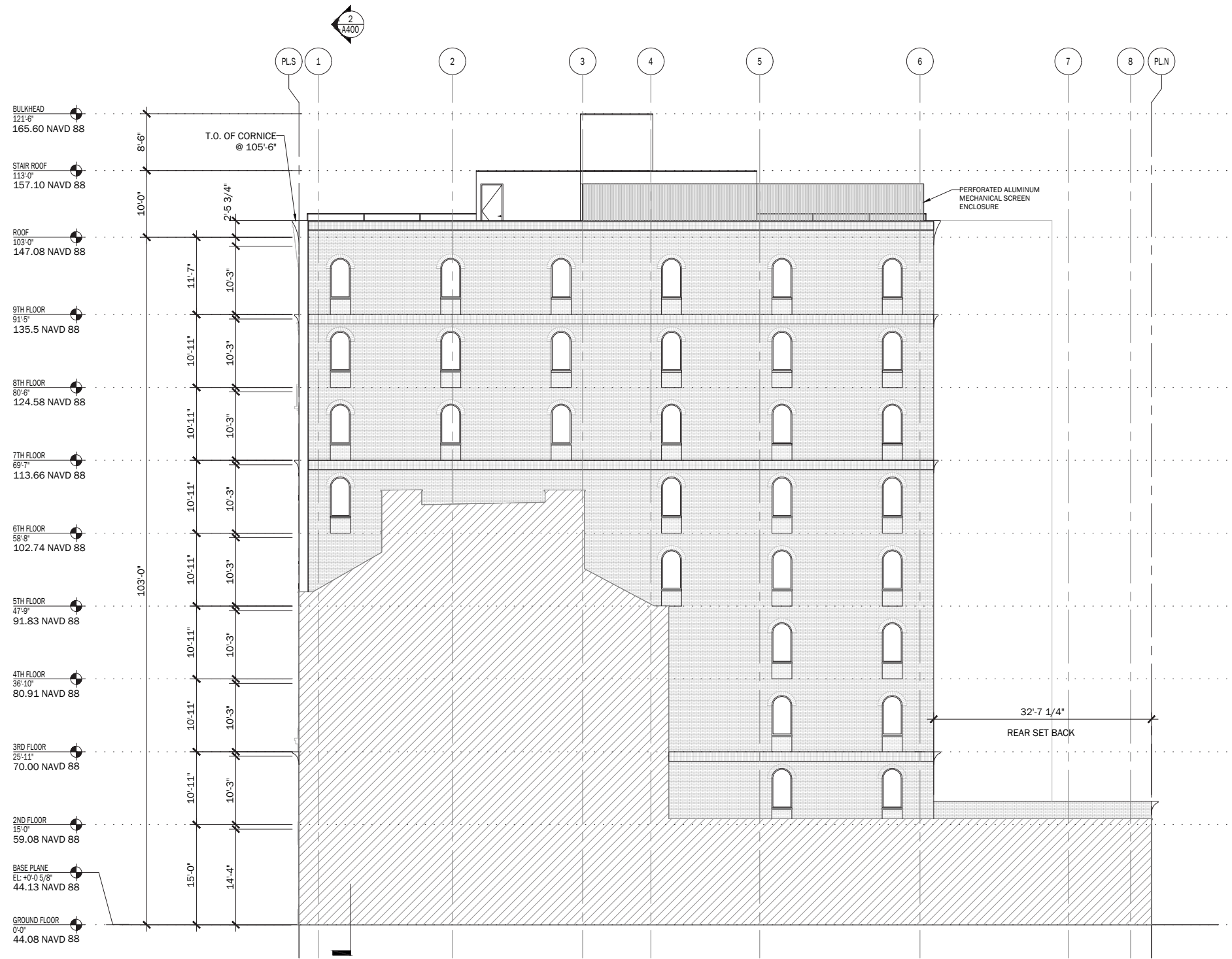

1	BUILDING ELEVATION - EAST	3/32"=1'-0"
---	---------------------------	-------------

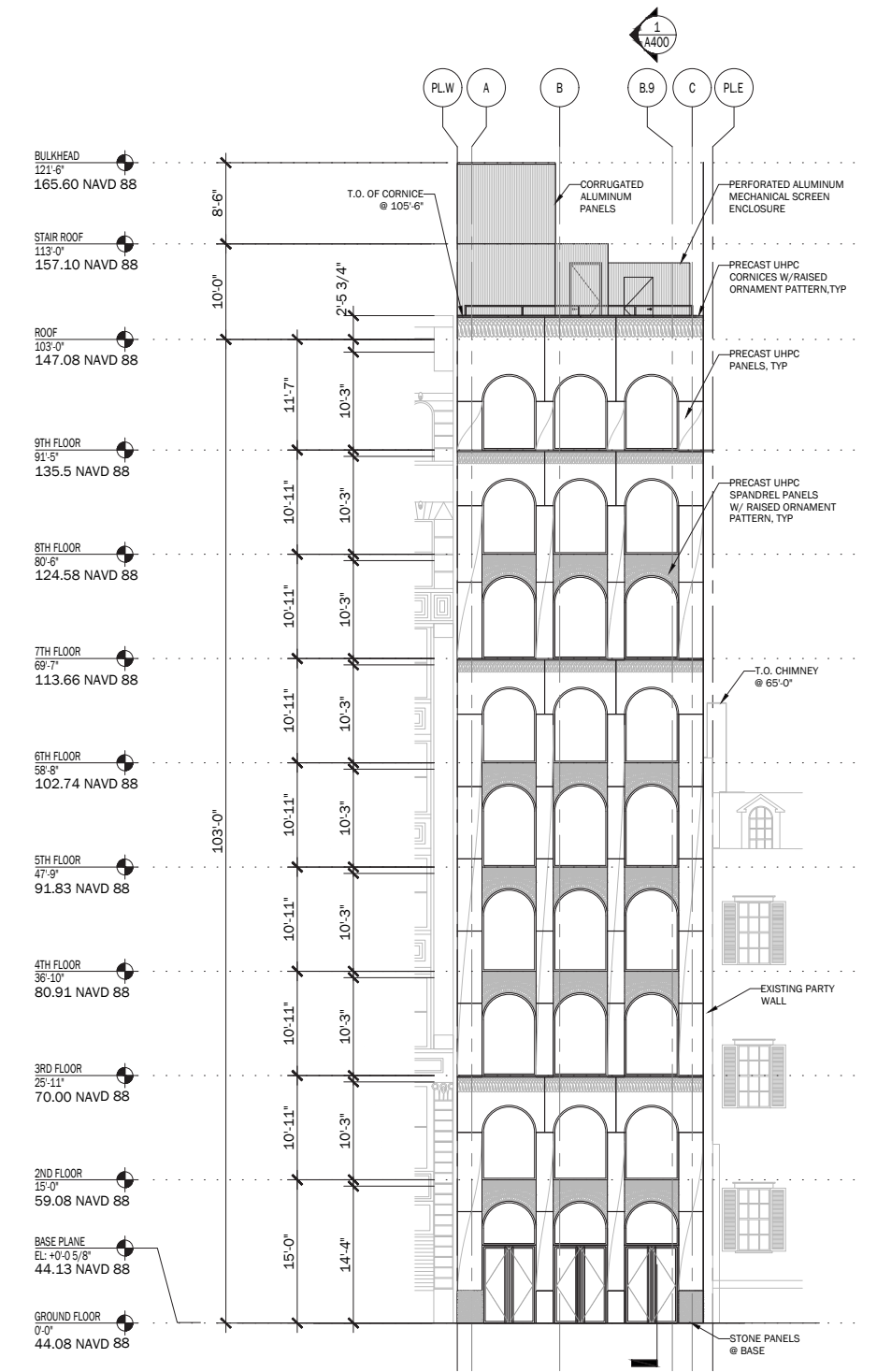

2	BUILDING ELEVATION - SOUTH	3/32"=1'-0"
---	----------------------------	-------------

27 EAST 4TH STREET – PROPOSED BUILDING ELEVATIONS



DXA studio
 © DXA studio
 dxastudio.com
 894 6th Avenue
 5th Floor
 NYC 10001
 T 212 874 0567



SCALE N/A
CLIENT
PROJECT NUMBER 25.29
DATE FEB 11, 2026

60

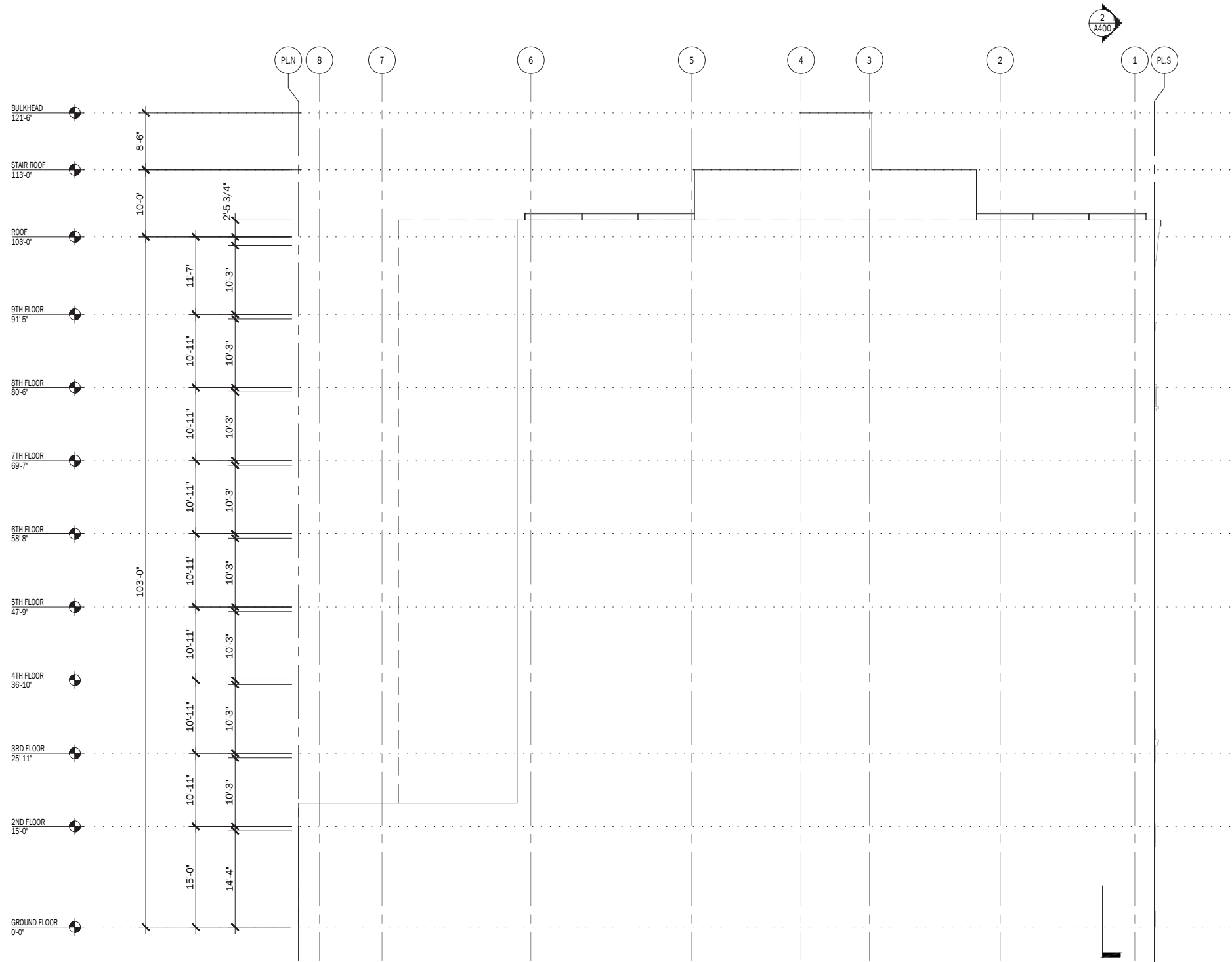

1 BUILDING ELEVATION - WEST 3/32"=1'-0"

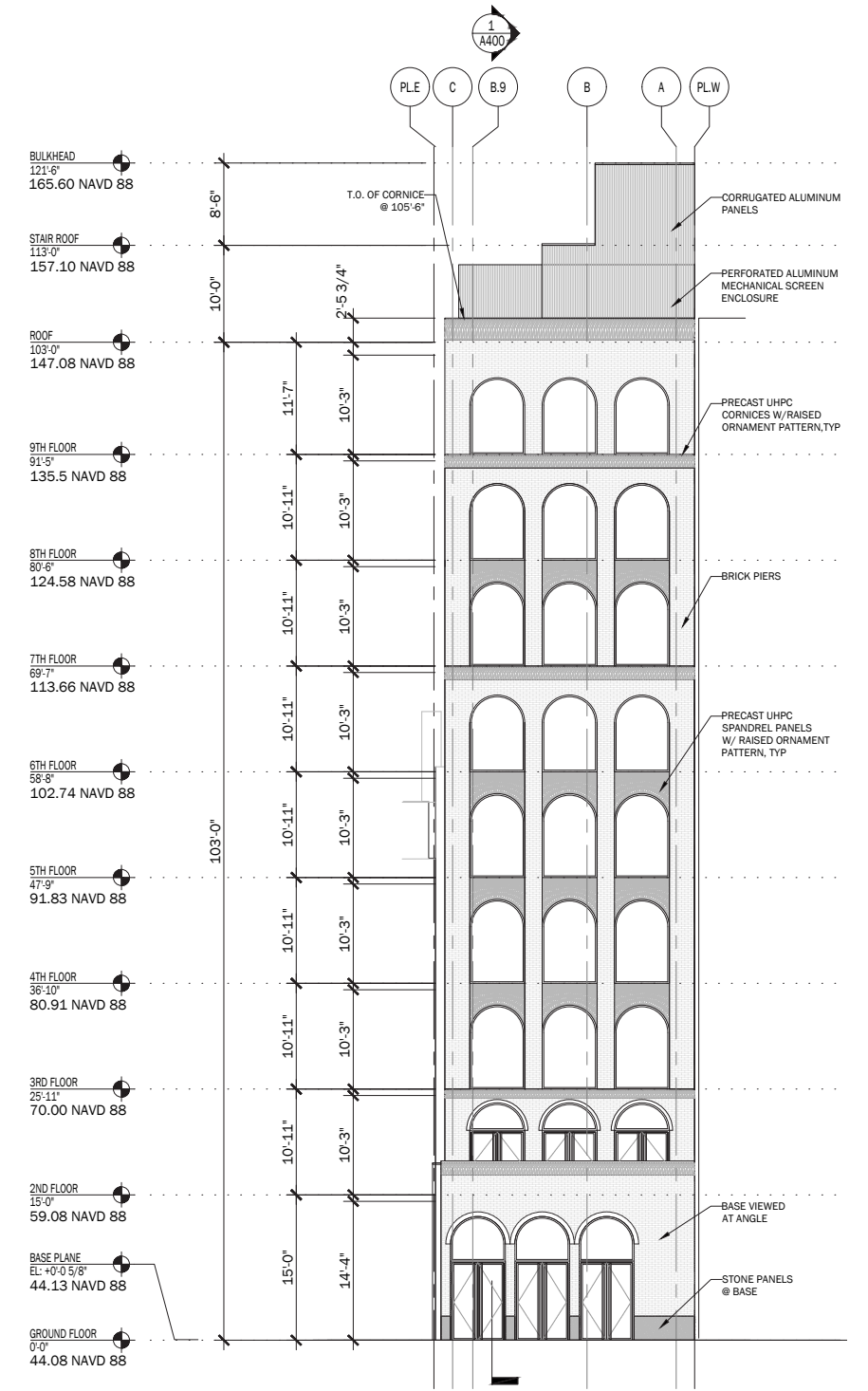

2 BUILDING ELEVATION - NORTH 3/32"=1'-0"

27 EAST 4TH STREET – PROPOSED BUILDING ELEVATIONS



DXA studio
 © DXA studio
 dxastudio.com

894 6th Avenue
 5th Floor
 NYC 10001
 T 212 874 0567



SCALE N/A
 CLIENT
 PROJECT NUMBER 25.29
 DATE FEB 11, 2026

61

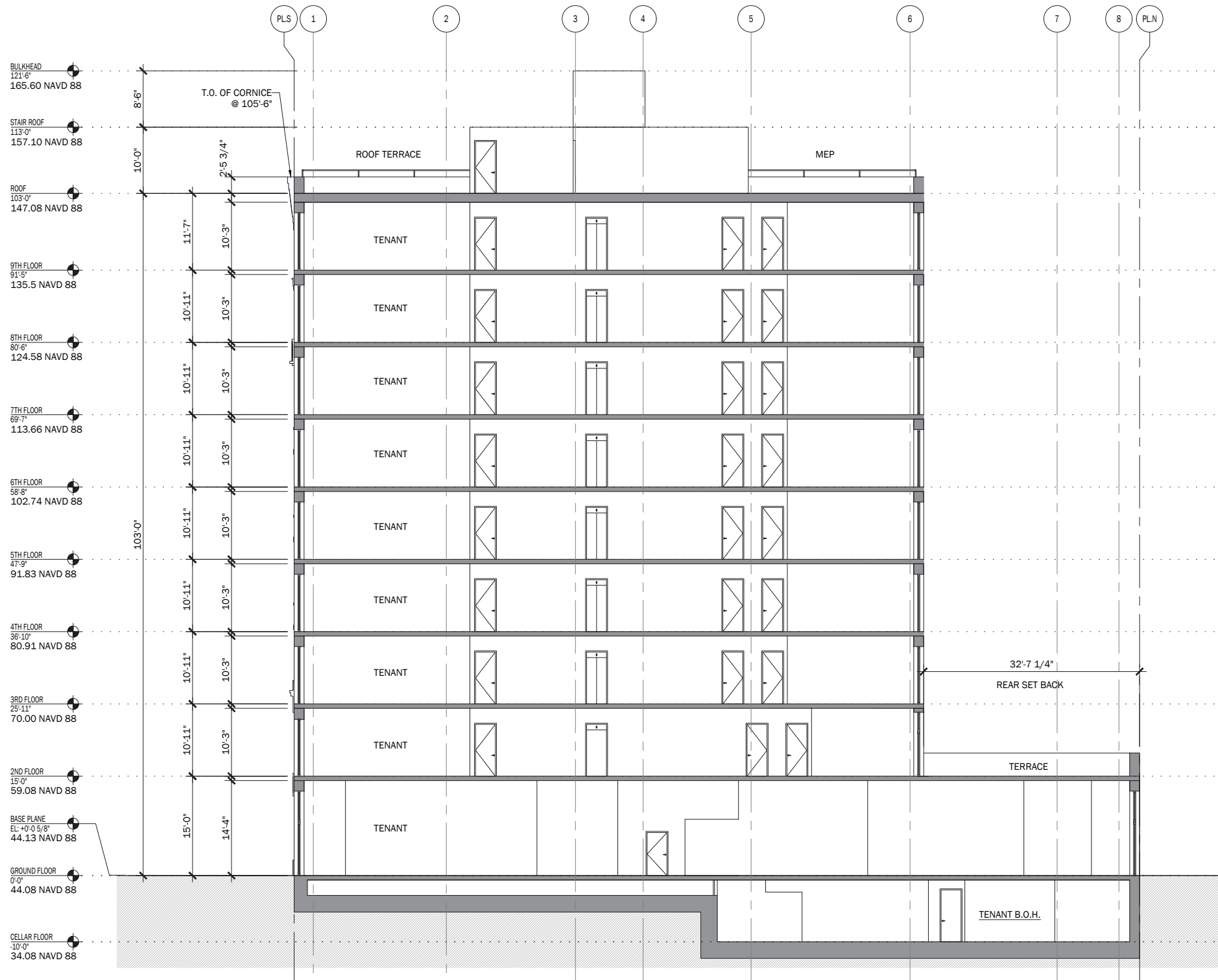

1 BUILDING SECTION NORTH - SOUTH 3/32"=1'-0"

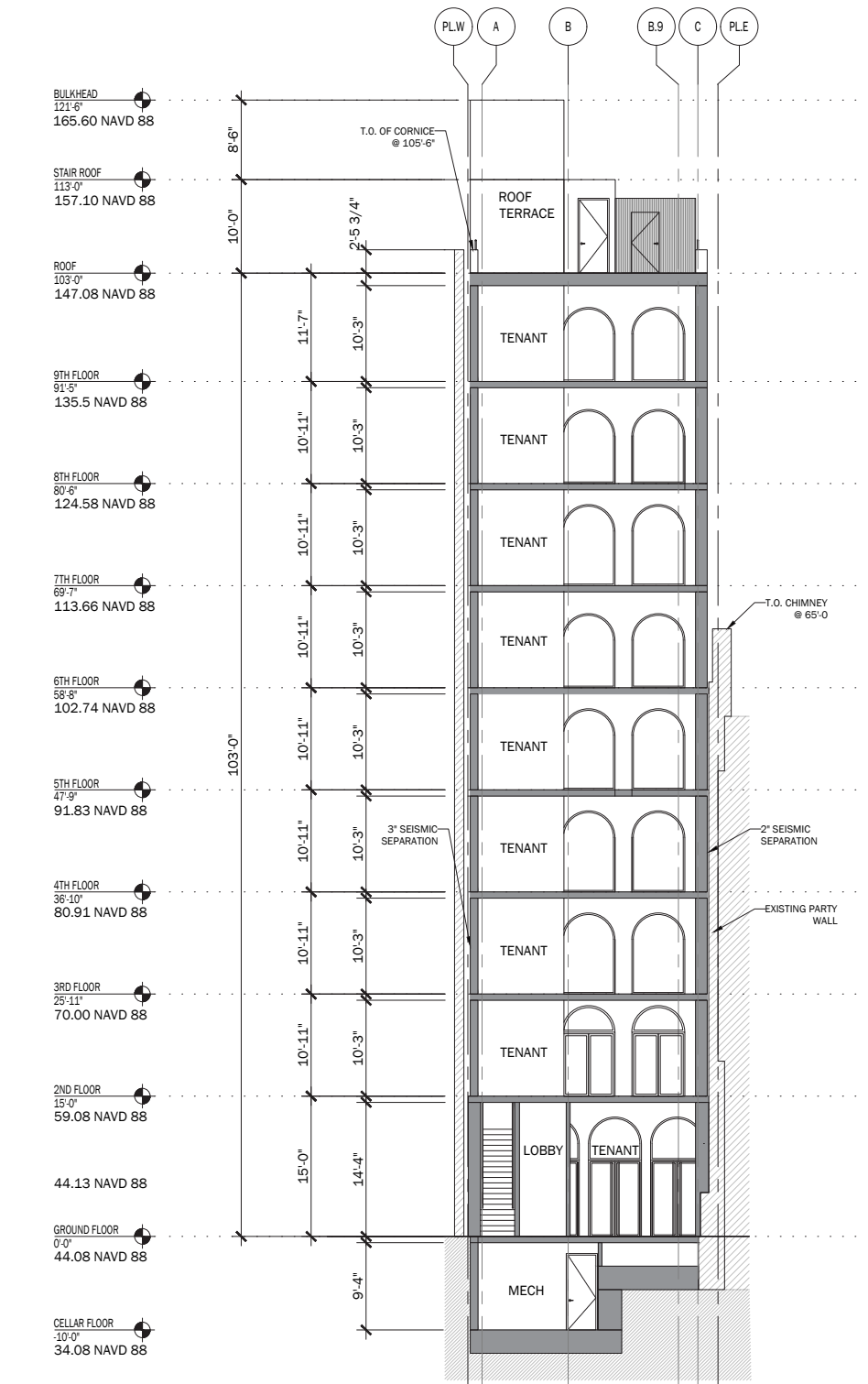

2 BUILDING SECTION EAST - WEST 3/32"=1'-0"

27 EAST 4TH STREET – PROPOSED BUILDING SECTIONS



DXA studio
 © DXA studio
 dxastudio.com

894 6th Avenue
 5th Floor
 NYC 10001
 T 212 874 0567



SCALE N/A
 CLIENT N/A
 PROJECT NUMBER 25.29
 DATE FEB 11, 2026

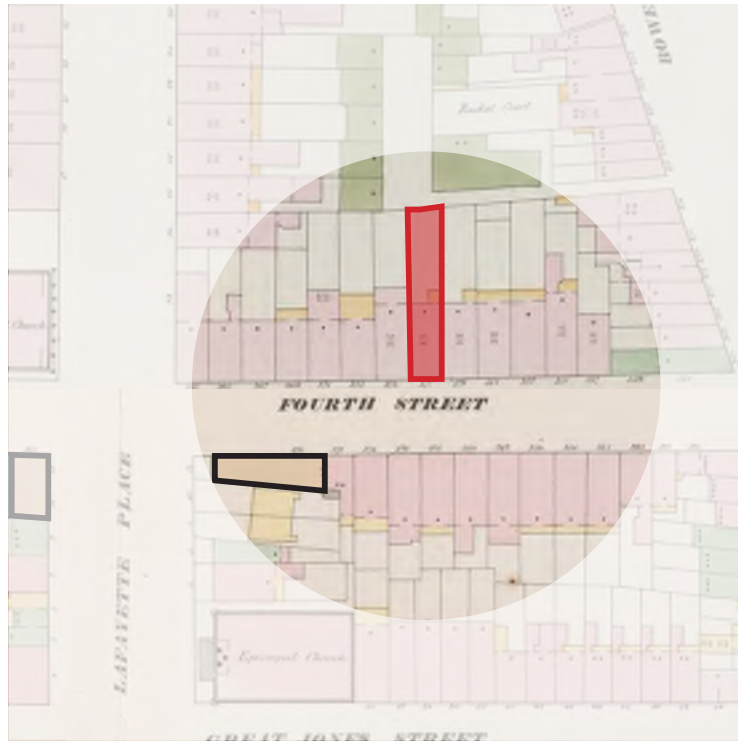

1857-62 PERRIS (NYPL)

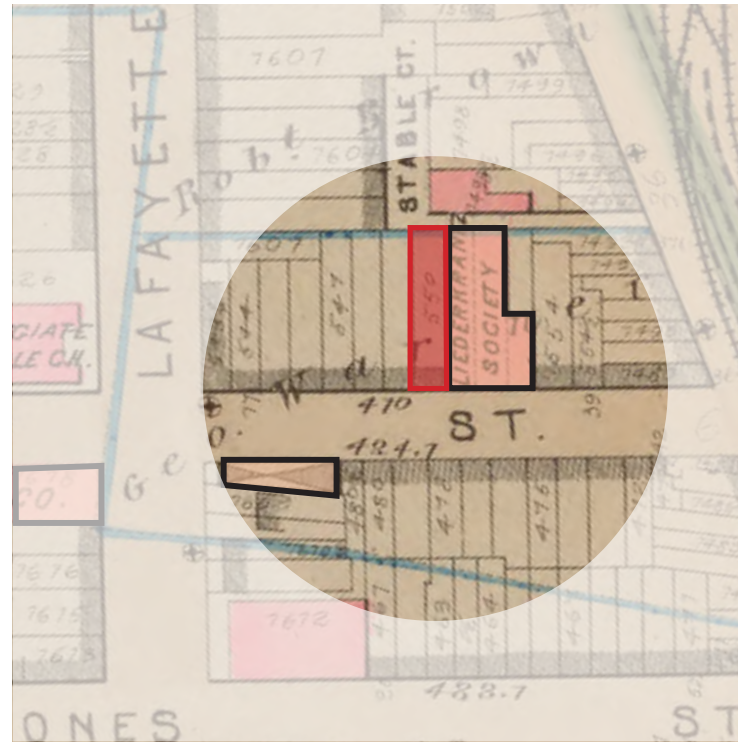

1879 BROMLEY (NYPL)

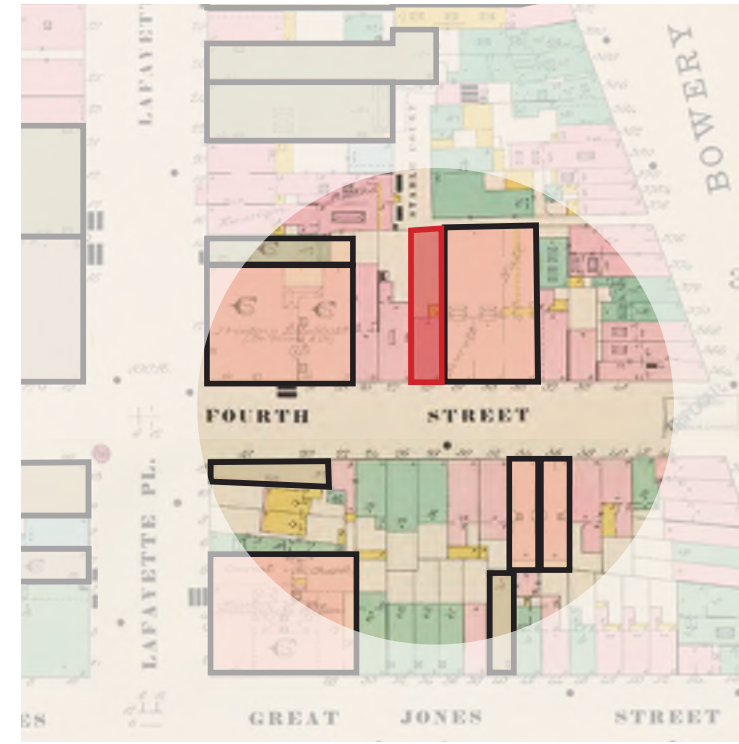

1895 SANBORN (NYPL)

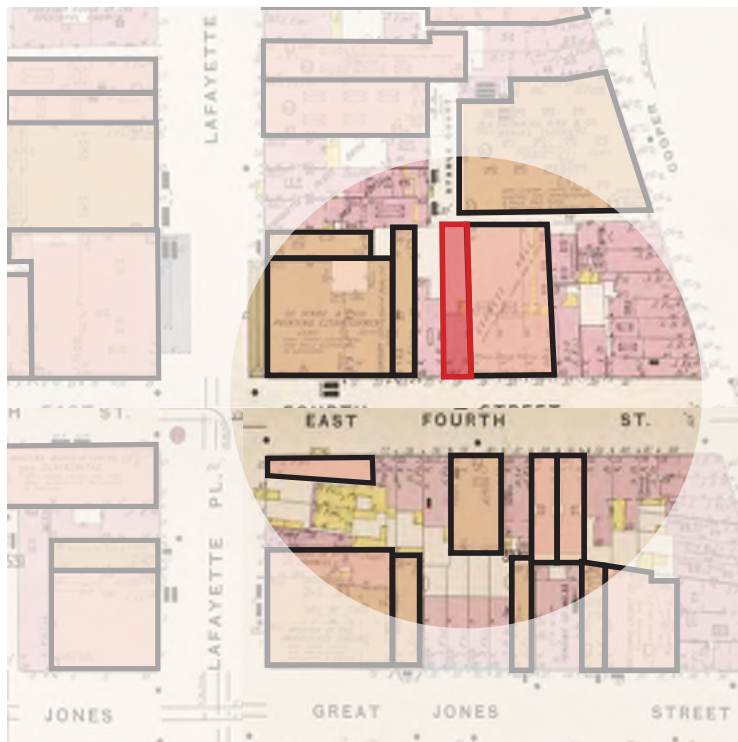

1904 SANBORN (NYPL)

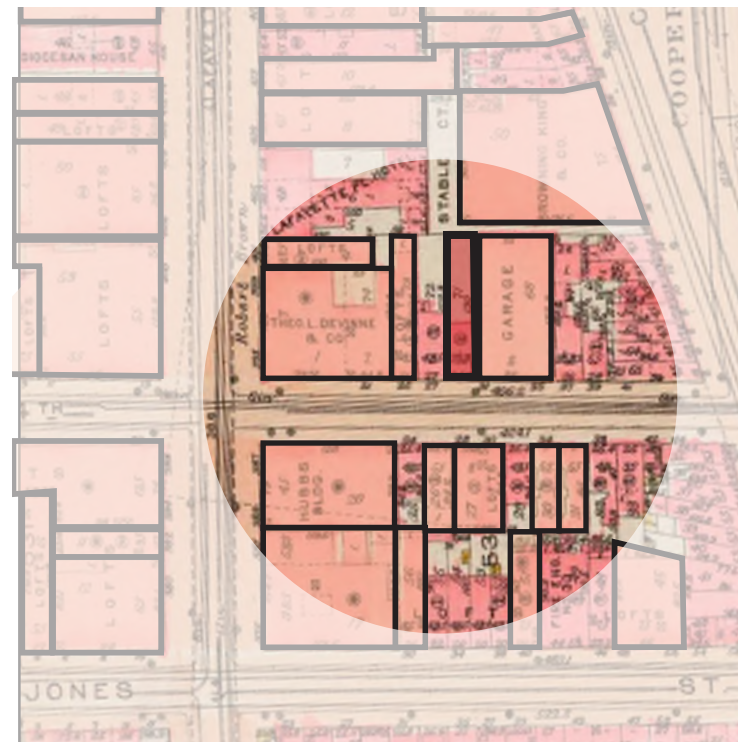

1923 SANBORN (NYPL)

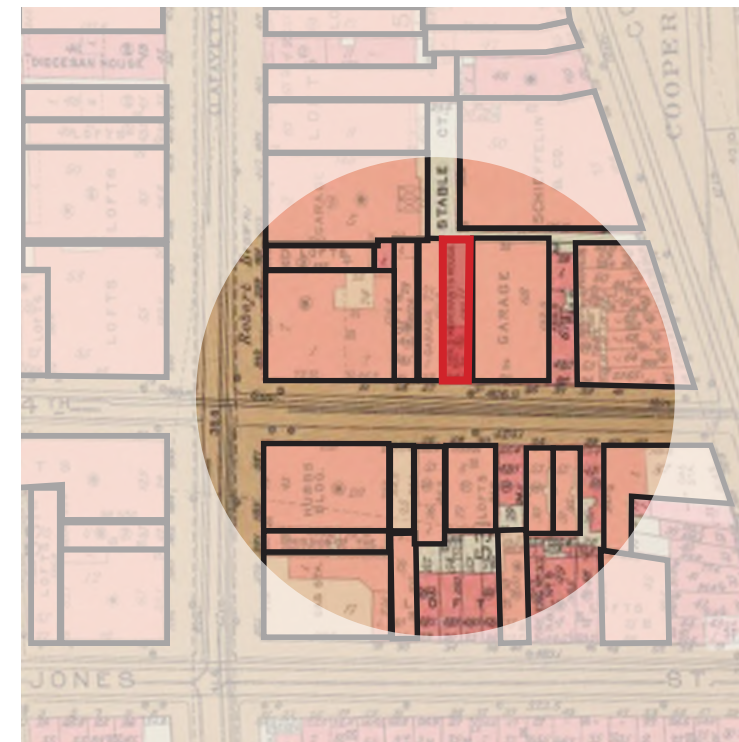

1956 TO PRESENT SANBORN (NYPL)

27 EAST 4TH STREET – CONSTRUCTION HISTORY OF SITES ADJACENT TO MERCHANT HOUSE



DXA studio
 894 6th Avenue
 5th Floor
 NYC 10001
 T 212 874 0567
 © DXA studio
 dxastudio.com



GMS GILSANZ MURRAY STEFICEK
 Structural Engineers and Building Envelope Consultants

SCALE N/A
 CLIENT
 PROJECT NUMBER 25.29
 DATE FEB 11, 2026