

SOHO GRAND HOTEL INC. AND HARTZ HOTEL SERVICES, INC.

APPLICATION FOR CHANGE IN METHOD OF OPERATION

**310 W. BROADWAY
NEW YORK, NEW YORK 10013**

MANHATTAN COMMUNITY BOARD 2
OCTOBER 2025

SLA LICENSING COMMITTEE

Questionnaire

1. SLA Application Change in Method of Operation
2. Diagram
3. Menu
4. Proximity Report
5. Photographs
6. Existing CB2 Stipulations

Bernstein Redo, P.C.
1177 Avenue of the Americas, 5th floor
New York, New York 10036
(212) 651-3100; donald@brpclaw.com

Questionnaire

Valerie De La Rosa, *Chair*
Eugene Yoo, *First Vice Chair*
Donna Raftery, *Second Vice Chair*
Mark Diller, *District Manager*



Antony Wong, *Treasurer*
Emma Smith, *Secretary*
Brian Pape, *Assistant Secretary*

COMMUNITY BOARD NO. 2, MANHATTAN

3 WASHINGTON SQUARE VILLAGE
NEW YORK, NY 10012-1899

www.manhattancb2.org

P: 212-979-2272 F: 212-254-5102 E: info@manhattancb2.org

Greenwich Village ♦ Little Italy ♦ SoHo ♦ NoHo ♦ Hudson Square ♦ Chinatown ♦ Gansevoort Market

COMMUNITY BOARD 2 APPLICATION FOR A LIQUOR LICENSE

Please fill out this questionnaire, including the date, and return to the Community Board 2 office by email to arrive **no later than the month's due date** which can be found on CB2 Manhattan's website (<https://cbmanhattan.cityofnewyork.us/cb2/resources/sla-questionnaire/>). When meetings return to in person, please also provide an additional 5 copies plus supporting material requested to the SLA committee meeting.

Failure to complete and return the questionnaire and supporting materials on time will result in your item being removed from the agenda.

Failure to provide a completed questionnaire or failure to present before CB2 will result in notifying the State Liquor Authority (SLA) of your noncompliance with the community review process.

If you need to reschedule, please notify the Community Board 2 office no later than the Friday prior to the scheduled meeting. Speak to Florence Arenas at the Board Office. **A maximum of 1 layover request will be granted per application. Failure to reappear without notification will result in a recommendation to deny this application.**

The following supporting materials are **required** for this application:

1. A list of all other licensed premises (including Beer and Wine) within 500 ft. of this location.
2. If the license being applied for is subject to the 500 ft. rule, please provide a copy of the public interest statement that will be submitted to the SLA.
3. Floor plans of the premise, clearly indicating the location of all entrances and exits, windows, bars, tables and chairs, patron and employee bathroom(s) and kitchen layout to be licensed. Please include seat and table counts on the plans for each area. If **outdoor seating of any kind** is included in the application please download and complete **CB2 SLA's Addendum for Outdoor Seating**. For any multi-floor, multi-room or hotel applications, please provide detailed plans for each floor and/or separate areas to be included in the licensed premises that are clearly labeled.
4. Proposed menu with general price ranges, if applicable.
5. Certificate of Occupancy or Letter of No Objection for the premises showing that the proposed use is permitted, including specific use of all outdoor areas within the property line.
6. If unable to show the proposed use is permitted, including for outdoor areas within the property line, please provide a detailed explanation for how the proposed use sought will be permitted and please provide any plans filed or to be filed with the Buildings Department.
7. Letter of Understanding or Letter of Intent from the Landlord.

8. Provide proof of community outreach to area block associations and immediately impacted residents in the building and surrounding area to notify them of your pending application and Community Board meeting information. Copies of any mailings to, and signatures or letters from Residential Tenants at location and from surrounding buildings may be submitted with home address and contact information. (i.e. a letter from the neighborhood block association or petition in support with home address and contact information.)
9. A copy of your NYS Liquor Authority application as it will be submitted to the SLA (excluding financial information).
10. If this is for a **Corporate Change**, please provide the **Current Approved Corporate Set-Up and the Proposed Corporate Set-Up** along with existing executed stipulations with CB2 if applicable.
11. If this is for any type of **Alteration Application**, please provide detailed information regarding the current situation and the proposed changes outlined as an addendum. If adding or subtracting space, please provide current and proposed diagrams.
12. If this application is for a **Change in Method of Operation**, please provide the current method of operation and the proposed changes in method of operation as an addendum.

APPLICANT INFORMATION:

Name of applicant(s):

Soho Grand Hotel, Inc. & Hartz Hotel Services Inc.

Trade name (DBA):

Soho Grand Hotel & Gilligan's

Premises address:

310 West Broadway

Cross Streets and other addresses used for building/premise:

Between Grand Street & Canal Street

CONTACT INFORMATION:

Principal(s) Name(s):

Ellis Yee, Vice-President

Office or Home Address: c/o Soho Grand Hotel

City, State, Zip:

[Redacted]

Telephone #:

[Redacted]

Landlord Name / Contact:

N/A - Soho Grand Hotel, Inc.

Landlord's Telephone and Fax: N/A

NAMES OF ALL PRINCIPAL(s):

NAMES / LOCATIONS OF PAST / CURRENT LICENSES HELD

Leonard Stern, Leonard Stern Trust, Edward Stern, Edward Stern Trust, SGH Special Shareholder, Lawrence Garb, Frank E. Roscitt

Soho Grand Hotel, Inc. d/b/a Soho Grand Hotel - 310 West Broadway

Vincent Rubino Jr, Leonard Stern Richard J. Milder, Ellis Yee, Phillip Patton

Tribeca Grand Hotel, Inc - 2 Avenue of the Americas

Constantino Milano, & Tony Fant

320 W. Broadway Diner Corp - 320 W. Broadway

5 CSH Operating LLC - 25-33 Cooper Square (inactive)

Briefly describe the proposed operation (i.e. "We are a family restaurant that will focus on..."):

24 Hour Hotel with outdoor service in side area called Gilligan's. This is a change in method of operation for the ability to have limited

recorded background music outside.

WHAT TYPE(S) OF LICENSE(S) ARE YOU APPLYING FOR (MARK ALL THAT APPLY):

- a new liquor license (Restaurant Tavern / On premise liquor Other)
- an UPGRADE of an existing Liquor License
- an ALTERATION of an existing Liquor License
- a TRANSFER of an existing Liquor License
- a HOTEL Liquor License
- a DCA CABARET License
- a CATERING / CABARET Liquor License
- a BEER and WINE License
- a RENEWAL of an existing Liquor License
- an OFF-PREMISE License (retail)
- OTHER : Change in Method of Operation

If upgrade, alteration, or transfer, please describe specific nature of changes:
(Please include physical or operational changes including hours, services, occupancy, ownership, etc.)

Change in method of operation. This request is to have limited music outside in the form of recorded background music through

small speakers distributed throughout the premises and a acoustic plan designed to reduce any sound leaks beyond premises.

If this is for a new application, please list previous use of location for the last 5 years:

N/A - the premises have been licensed and used as the Soho Grand for nearly two decades.

Is any license under the ABC Law currently active at this location? yes no

If yes, what is the name of current / ~~previous~~ licensee, license # and expiration date: _____

Soho Grand Hotel Inc & Hartz Hotel Services Inc / 0343-23-112654 (Exp June 2027)

Have any other licenses under the ABC Law been in effect in the last 10 years at this location?

yes no

If yes, please list DBA names and dates of operation:

Not applicable.

PREMISES:

By what right does the applicant have possession of the premises?

Own Lease Sub-lease Binding Contract to acquire real property other: _____

Type of Building: Residential Commercial Mixed (Res/Com) Other: _____

Number of floor: 16 Year Built : 1996

Describe neighboring buildings:

Commercial, Mixed Use, Residential and Industrial

Zoning Designation: M1-5A

Zoning Overlay or Special Designation (applicable) None

Block and Lot Number: 227 / 28

Does the premise occupy ~~more than one building, zoning lot, tax lot or more than one floor?~~ yes no

Is the premise located in a historic district? yes no

~~(if yes, have all exterior changes or changes governed by the Landmarks Preservation Commission (LPC) been approved by the LPC? yes no, please explain : _____)~~

Will any outside area or sidewalk café be used for the sale or consumption of alcoholic beverages? (including sidewalk, roof and yard space) no yes : explain Outdoor patio area adjacent to hotel

What is the proposed Occupancy? 1000+ (Entire Building & Outdoor Area)

Does the premise currently have a valid Certificate of Occupancy (C of O) and all appropriate permits?

no yes

If yes, what is the maximum occupancy for the premises? 1000+ (Entire Building)

If yes, what is the use group for the premises? Use Group 5

If yes, is proposed occupancy permitted? yes no, explain : _____

If your occupancy is 75 or greater, do you plan to apply for Public Assembly permit? yes no

*Already have PA

Do you plan to file for changes to the Certificate of Occupancy? yes no
(if yes, please provide copy of application to the NYC DOB)

Will the façade or signage be changed from what currently exist at the premise? no yes

(if yes, please describe: _____)

INTERIOR OF PREMISES:

What is the total licensed square footage of the premises? Approximately 189,986 sq. ft
Ground Floor: Approximately 12,805 sq. ft.
If more than one floor, please specify square footage by floors: Hotel Floors Approximately 19,138 sq. ft. per floor

If there is a sidewalk café, rear yard, rooftop, or outside space, what is the square footage of the area?
Approximately 4,995 sq. ft. of usable outdoor patio space.

If more than one floor, what is the access between floors? Elevator/Stairs

How many entrances are there? 2 How many exits? 4* How many bathrooms? 6 (not incl. guest rooms/ faculty facilities)
*Additional emergency exist from hotel.

Is there access to other parts of the building? no yes, explain: Emergency exits/ADA access to adjacent retail space.

OVERALL SEATING INFORMATION:

Total number of tables? In: 31 Out: 14 Total table seats? In: 129 Out: 48

Total number of bars? 4 Total bar seats? In: 16 Out: 8

Total number of "other" seats? In: 11/Out: 50 please explain : In: lounge seating, Out: bench seating

Total OVERALL number of seats in Premises : Approximately 262

BARS: (No new bars requested, all bars currently licensed) Main Bar: 8
Club Room (Main): 8
Club Room (add'l): 0

How many *stand-up bars / bar seats are being applied for on the premises? Bars 4 Seats Outdoor: 8

How many service bars are being applied for on the premises? 0

Any food counters? no yes, describe : _____

For Alterations and Upgrades: N/A

Please describe all current and existing bars / bar seats and specific changes: _____

* A stand-up bar is any bar or counter (whether seating or not) over which a member of the public can order, pay for and receive food and alcoholic beverages.

PROPOSED METHOD OF OPERATION:

What type of establishment will this be? (check all that apply)

Bar Bar & Food Restaurant Club/ Cabaret Hotel Other: _____

What are the Hours of Operation? * Hotel operates 24 hours a day, 7 days a week. The hours identified below are for the outdoor area. All other hours will remain the same.

Sunday: 10am to 10:00pm Monday: 8am to 10:00pm Tuesday: 8am to 10:00pm Wednesday: 8am to 10:00pm Thursday: 8am to 11:00pm Friday: 8am to 11:00pm Saturday: 8am to 11:00pm
** OUTDOOR HOURS **

Will the business employ a manager? ___ no yes, name / experience if known : Current hotel management

Will there be security personnel? ___ no yes(if yes, what nights and how many?) 4-5 daily
Do you have or plan to install French doors, accordion doors or windows that open? no ___ yes

If yes, please describe : _____

Will you have TV's ? no ___ yes (how many?) _____

Type of MUSIC / ENTERTAINMENT: Live Music Live DJ ___ Juke Box Ipod / CDs ___ none
*Inside only

Expected Volume level: Background (quiet) Entertainment level Amplified Music
(check all that apply) *Inside only *Inside only

Do you have or plan to install soundproofing? ___ no yes

IF YES, will you be using a professional sound engineer? YES

Please describe your sound system and sound proofing: Interior - no changes to existing sound system.

Will you be permitting: promoted events scheduled performances ___ outside promoters
*promoted in the sense that there may be press concerning a special event, not that there will be third-party promoters. **Inside only.
 any events at which a cover fee is charged? private parties

Do you have plans to manage or address vehicular traffic and crowd control on the sidewalk caused by your establishment? ___ no yes (if yes, please attach plans) Please see attached security plan.

Will you be utilizing ropes ___ movable barriers ___ other outside equipment (describe) _____

Are your premises within 200 feet of any school, church or place of worship? no ___ yes

If there is a school, church or place of worship within 200 feet of your premises or on the same block, please submit a block plot diagram or area map showing its' location in proximity to your applicant premises (no larger than 8 1/2 " x 11").

Indicate the distance in feet from the proposed premise:

Name of School / Church: _____

Address: _____ Distance: _____

Name of School / Church: _____

Name of School / Church: _____

Address: _____ Distance: _____

Name of School / Church: _____

Address: _____ Distance: _____

Please provide contact information for Residents / Community Board and confirm that if complaints are made you will address it immediately.

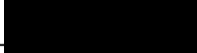
Contact Person: 24 Hour Live Operator to Manager on Duty Phone: 

Address: 310 West Broadway, New York, NY 10013

Email : 

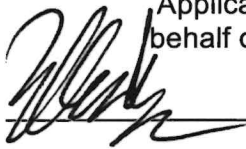
X  Application submitted on behalf of the applicant by: _____
Signature

Print or Type Name Ellis K. Yee

Title Vice President

Thank you for your cooperation. Please return this questionnaire along with the other required documents as soon as you can. This will expedite your application and avoid any unnecessary delays. Use additional pages if necessary.

Community Board 2,
Manhattan SLA Licensing
Committee Donna Raftery, Chair

Valerie De La Rosa, Chair
Eugene Yoo, First Vice Chair
Donna Raftery, Second Vice Chair



Antony Wong, Treasurer
Emma Smith, Secretary
Brian Pape, Assistant Secretary
Mark Diller, District Manager

Community Board No. 2, Manhattan

3 Washington Square Village
NEW YORK, NY 10012-1899

www.manhattancb2.org

P: 212-979-2272 F: 212-254-5102 E: info@manhattancb2.org

Greenwich Village ♦ Little Italy ♦ SoHo ♦ NoHo ♦ Hudson Square ♦ Chinatown ♦ Gansevoort Market

COMMUNITY BOARD 2 APPLICATION FOR A STATE LIQUOR AUTHORITY LICENSE ADDENDUM FOR OUTDOOR SEATING

For a Liquor License Application that includes any outdoor areas, please complete the following:

- Submit a diagram of outdoor seating indicating length and width of area(s) and location of all tables and chairs. Include all obstructions (trees, fire hydrants, proximity to bus stops, bike racks, signs, etc.).
- Submit photos of the premises where the sidewalk café and/or roadbed will be located. Required photos show one frontal, one left and one right side view of proposed sidewalk café and/or roadbed.
 - Photos must show complete sidewalk and/or roadway area where sidewalk café and/or roadbed will be including views to curb and neighboring properties.
 - For rear yard, show photos of yard and surrounding area, including upper view of adjacent buildings.

Name of Applicant: Soho Grand Hotel Inc & Hartz Hotel Services, Inc.

Address of Premises: 310 W. Broadway, New York, New York 10013

~~Sidewalk café will have no more than (If premises is located on a corner please indicate for both streets):~~

~~_____ tables and _____ seats on _____ Street~~

~~_____ tables and _____ seats on _____ Street~~

~~Hours of sidewalk café: _____ to _____.~~

~~Describe any obstructions (trees, fire hydrant, proximity to bus stop, etc): _____~~

~~Roadbed will have no more than (If premises is located on a corner please indicate for both streets):~~

~~_____ tables and _____ seats on _____ Street~~

~~_____ tables and _____ seats on _____ Street~~

~~Hours of roadbed: _____ to _____.~~

~~Describe any obstructions (trees, fire hydrant, proximity to bus stop, etc): _____~~

Rear yard / Rooftop (circle) will have no more than 14 tables and 48 (table) seats

Hours of rear yard / rooftop: 8am to 10pm Weekdays* 8 (bar seats)

8am to 11pm Thursday - Sat

*10am opening on Sunday

Does seating extend beyond the business frontage? No Yes

Will outdoor dining structures **on the sidewalk** be enclosed on three (3) or more sides? No Yes N/A

Will outdoor dining structures **on the roadbed** be enclosed on three (3) or more sides? No Yes N/A

Is there any outdoor music, speakers or TVs? No Yes, please describe: See attached sound report

Will heating elements be used? No Yes, please describe: _____

19 Mercer Street, New York, NY 10013 (212) 925-1365 acoustilog1@verizon.net

August 8, 2025

Mr. Ellis Yee
Soho Grand Hotel
310 West Broadway
New York, NY 10013

Re: Soho Grand Hotel

Dear Mr. Yee,

I tested the sound levels on the outdoor patio on the south side of the hotel on August 5, 2025 at 11:00 AM. There have been noise complaints in the past from nearby residents.

SUMMARY

The recommendations in this report will ensure that the sound levels in neighboring buildings will comply with the applicable Noise Code limits.

DBA VS ONE-THIRD OCTAVE BAND MUSIC LEVELS

One way that sound levels are often measured is by using the "A scale", the A-weighted decibel scale. This dBA scale (see Noise Code Section §24-231 a1) is the most common type of sound measurement, which represents a summation of middle (midrange) and high frequencies (treble), but largely ignores low-frequency "bass" sounds. Measuring the dBA levels requires only a simple sound level meter. DBA is what the City DEP inspectors usually use, and they normally consider anything above 42 dBA to be unreasonable.

C-weighted decibels or dBC (see Noise Code Section §24-231 a3) are also a measurement of all frequencies, but this method includes the important low-frequency "bass" sounds. However, dBC readings pick up so many frequencies at the same time that they usually do not distinguish between normal background noise and music beats.

One-third-octave band sound level readings (see Noise Code Section §24-231 a2) were also taken, which are measured in decibels, or dB. Sounds with frequencies from 250 Hertz to 1 Kilohertz are called midrange frequencies. This range of midrange frequencies is addressed in the Noise Code regulations and is the sound that is most likely to be causing complaints from neighbors. These sounds require a complex spectrum analyzer to measure them.

THE NOISE CODE - MUSIC

§24-231 Commercial music.

(a) No person shall make or cause or permit to be made or caused any music originating from or in connection with the operation of any commercial establishment or enterprise when the level of sound attributable to such music, as measured inside any receiving property dwelling unit:

(1) is in excess of 42 dB(A) as measured with a sound level meter; or

(2) is in excess of 45 dB in any one-third octave band having a center frequency between 63 hertz and 500 hertz (ANSI bands numbers 18 through 27, Inclusive), in accordance with American National Standards Institute standard S1.6-1984; or

(3) causes a 6 dBC or more increase in the total sound level above the ambient sound level as measured in decibels in the "C" weighting network provided that the ambient sound level is in excess of 62 dBC.

TEST

Prerecorded music was played through an amplifier hooked up to a small speaker on the patio. This speaker was mounted approximately 8 feet above the ground at the bar located in the south section of the patio.

First, the sound system was set to the desired level that will be used in the future. This level was measured and stored. Then, the sound level was turned up much louder for the test. The reason for playing the test level louder was to override the considerable noise from the surrounding traffic and mechanical equipment in the area.

The graph below shows the frequency content of both the test level and the desired level. The overall dBC level was 9 decibels louder for the test.

Measured Sound Levels- Patio

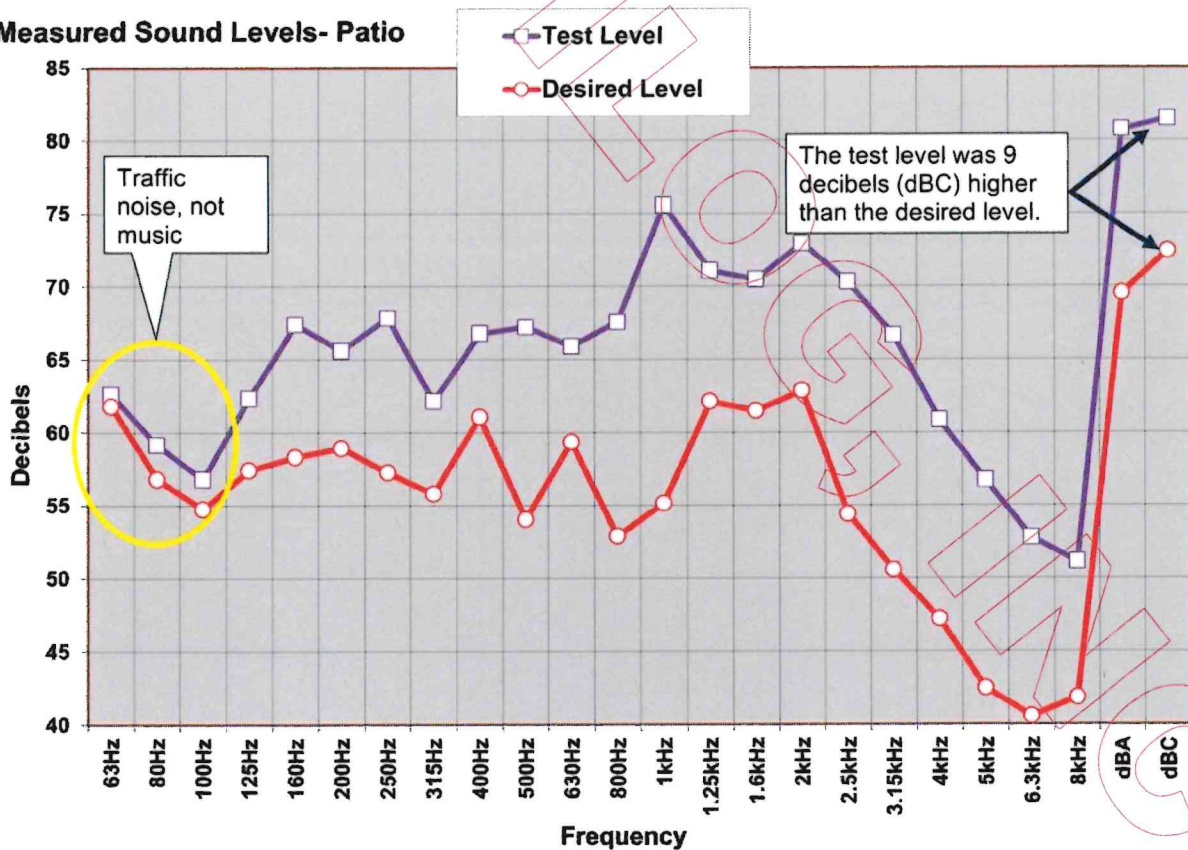

Sound levels were also measured in the top floor of the nearest residential building, 385 Canal Street. Because this top floor has a wider view of the entire patio, it actually picks up more sound than the lower floors. The measurement was made 3 feet from the fully open rear windows facing the patio. With the louder test level playing, the music was virtually inaudible. The music would be even lower and still inaudible if the sound system was played at the "desired" level. Voices from patrons are not expected to exceed the ambient levels in the apartments, particularly with the low sound system levels that will be used.

Measured Sound Levels: Apartment 5

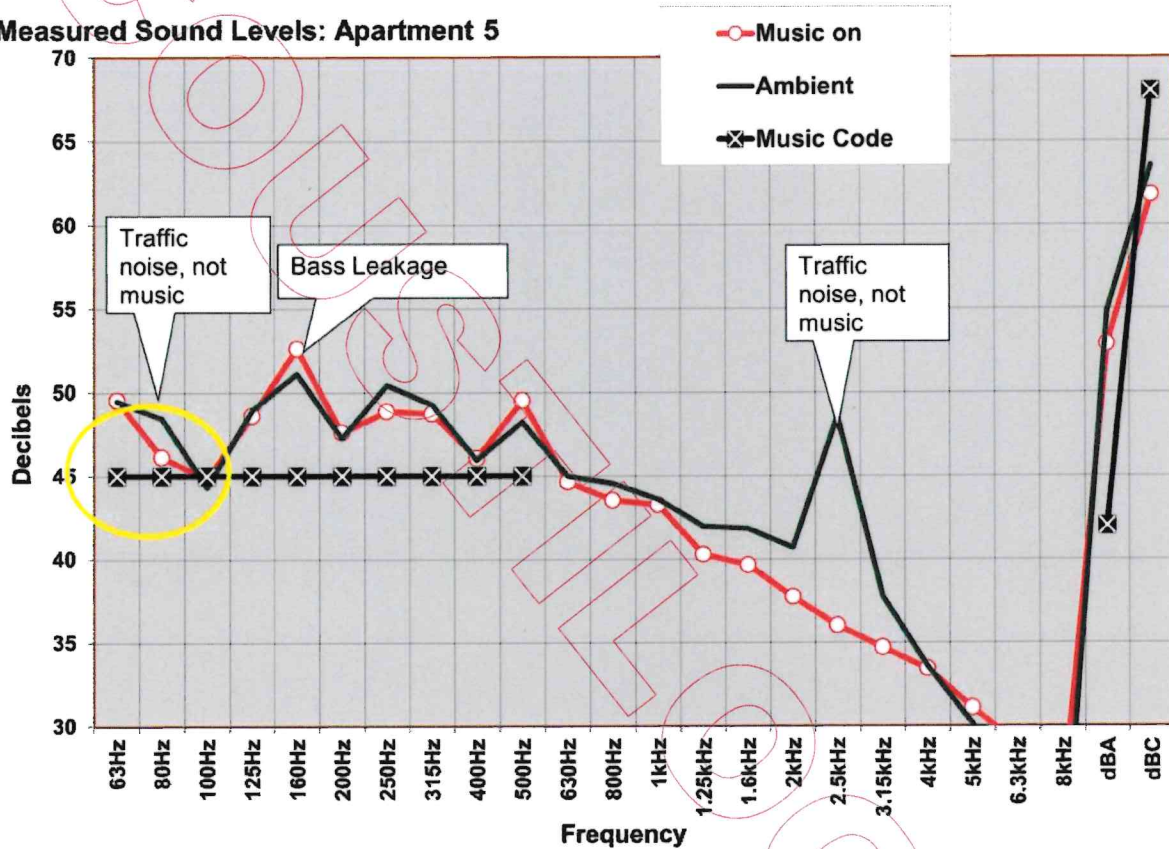

RECOMMENDATIONS

SOUND SYSTEM

1. The sound system should use distributed small speakers, rather than a few large (and therefore louder) speakers.
 - a. The woofers must not exceed 6" in diameter.
 - b. Small speakers such as Behringer Model 1C-BK, JBL Control 1 or Yamaha NS-AW150 are acceptable. Data attached.
 - c. Do not use subwoofers.
 - d. An acceptable speaker layout is shown in the diagram at the end of this report.
 - e. Do not install speakers in the east or middle sections of the patio.
 - f. All speakers should be mounted at a height of 8 feet and pointed down toward the customers.

2. The patio will be divided up into four zones such that the sound level can be balanced independently in each zone.
 - a. A zone control box can be used. Data attached.
 - b. Use #18 gauge zip cord for the low-volume speakers. Do not buy Monster cable.
3. Any good commercial stereo power amp of 75 watts per channel or higher, preferably without volume controls, can easily handle all the speakers.
4. The system should be set up in stereo. Stereo sounds louder to the customers without actually increasing the total sound that travels to neighboring buildings. Alternate the speakers left/right.
5. The sound system will incorporate an equalizer. The equalizer will then feed into a limiter. Both functions can be accomplished with a DBX DriveRack PA2 or similar processor, which is a deterrent to volume-abusing employees. Data attached. Installed in the system right before the amplifier and locked with a password, it will prevent the sound system from exceeding a pre-determined sound level, set by the sound installer. If the sound system is turned up too high, the limiter will activate and guarantee that the actual sound never exceeds the desired maximum.
 - a. The amplifier and zone control box have to be set to maximum level during this process so they cannot be turned up further at a later time. The zones on the control box can be turned down later if desired for balancing.
 - b. Using the crossover section, attenuate (lower) all frequencies 125 Hertz and below by setting a high-pass filter on both stereo channels to a cutoff frequency of 125 Hertz and a slope of 18 dB/octave.
 - c. Set the compressor Ratio control to infinity, Over-Easy to off, and the Threshold control so as to normally limit only 3 decibels while playing the loudest possible music. If the music tries to get louder, the sound will stay at the same volume.
 - d. Use the compressor Output level control to set the maximum sound level to 90 dBC and 85 dB, measured 8' from any of the loudspeakers. The sound installer can do this with a simple Radio Shack sound level meter. Set the meter to read "C", and "Slow". This is a good starting point from which to operate the system.
 - e. The system could be checked by testing in nearby apartments.
 - f. To ensure accuracy of the meter, one can bring it to my office to be calibrated.

If I can be of further assistance, please call.

It is strongly recommended that all complicated construction projects get regular inspection visits at critical times, to make sure the system performs properly. This is an optional service which I can provide. All Acoustilog, Inc.-designed information supplied is for the original client and may not be copied in any way for different projects by any architect, consultant, engineer or other party. Copyright Acoustilog, Inc. © 2025. All rights reserved. No reproduction of any type permitted without written permission of Acoustilog, Inc.

Yours Truly,

Alan Fierstein



President

acoustilog1@verizon.net

*All readings re: .0002 microbar and to Code.
Readings taken with Bruel & Kjaer 2250/2260/2270
Analyzer, Bruel & Kjaer 4134, 4135, 4145, 4155,
4165, 4189 or 4190 Microphone, Acoustilog 232A
Reverberation Timer. Calibrated to Bruel & Kjaer
4220 Sound Source or Quest CA-15.*



This is the south section of the patio which ends at Canal Street.



The west section



The east section of the patio will not be open to customers and will not have speakers.

CONFIDENTIAL

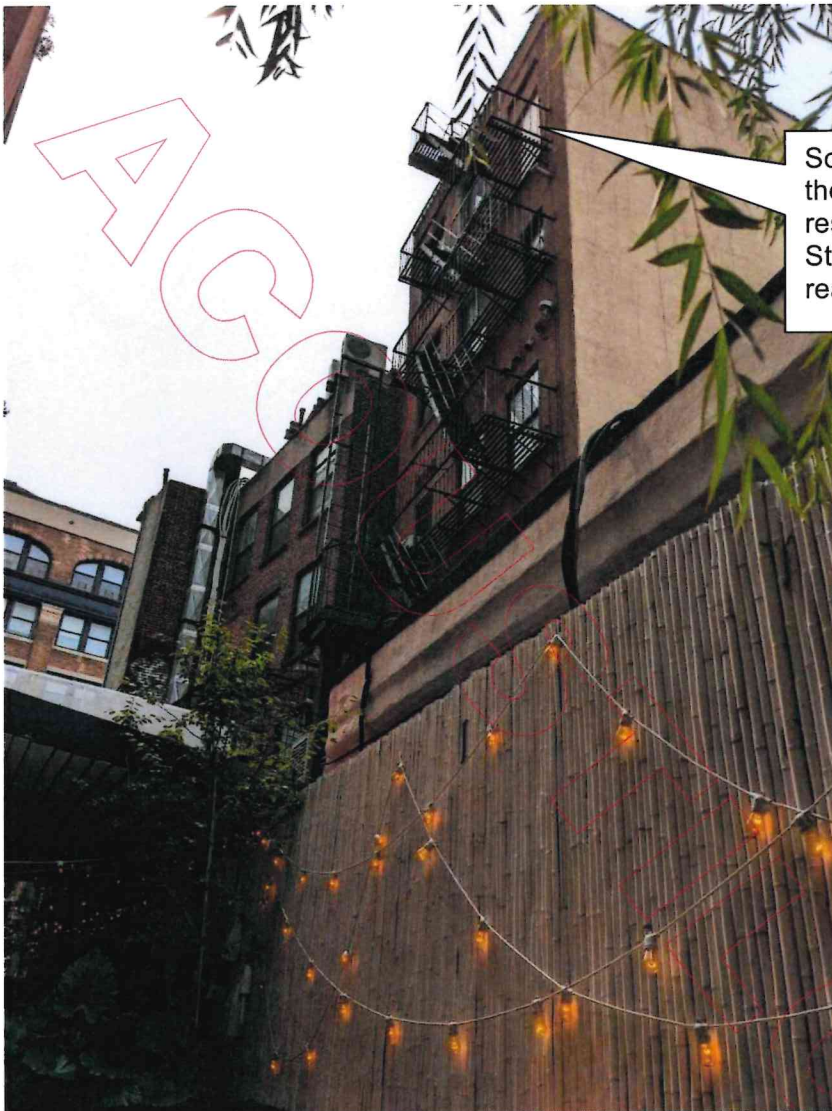

Sound levels were measured in the top floor of the nearest residential building, 385 Canal Street, 3 feet from the fully open rear windows facing the patio.

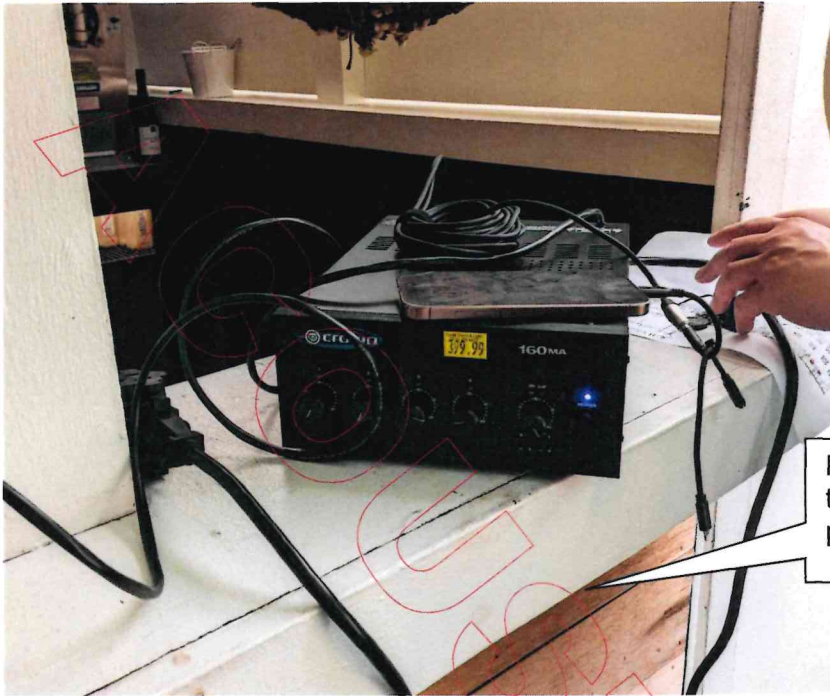

Prerecorded music was played through an amplifier on the patio.



A small speaker was hooked up to the amplifier.

EVIDENCE

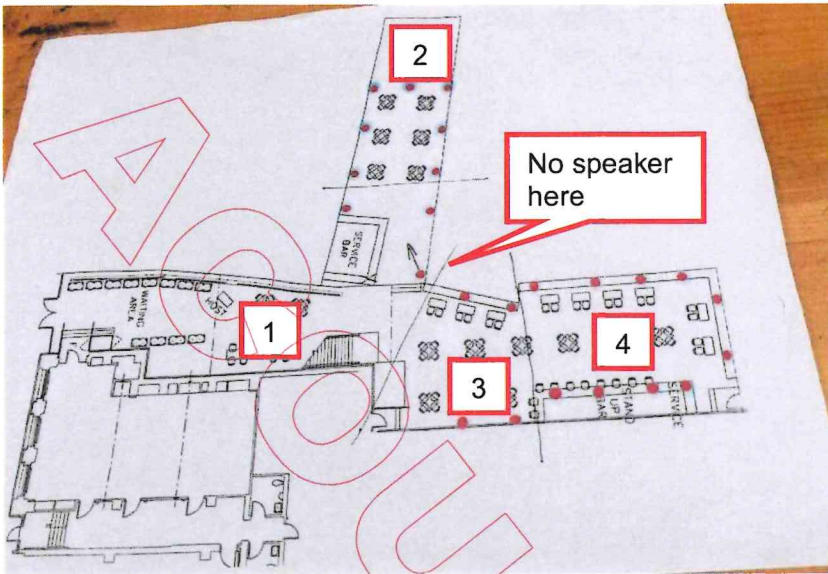

This layout, drawn by Jeffrey Kwan, meets the required criteria. Basically, the patio will be divided up into four zones where the sound level can be balanced independently in each zone. All speakers are mounted at a height of 8 feet and pointed down toward the customers.

- 1- No speakers
- 2- 9 speakers
- 3- 4 speakers
- 4- 10 speakers

Behringer Monitor Speakers 1C-BK - Black

5.5" 100W Passive 2-way Monitor Speakers for Fixed Installation (pair) - Black



High-precision components deliver incredible sound quality

1C-BK passive monitor speakers derive their massive sound from powerful 5.5" cellulose cone woofers and high-resolution 0.5" tweeters. Built with high-precision components, these speakers exhibit absolute phase linearity, delivering exceptionally clear sound reproduction and excellent frequency response from 60Hz all the way up to 23kHz. On top of that, you won't have to worry about blowing the 1C-BKs' tweeters, thanks to the auto-overload protection that's built into these speakers' low-distortion, phase-optimized crossovers. In other words, these little guys sound great!

Behringer 1C-BK Passive Monitor Speakers Features:

- Ultra-linear design delivers exceptionally clear sound reproduction and excellent frequency response
- High power handling capabilities provide full-range output with extremely low distortion
- Phase-optimized and high-precision crossovers for absolute phase linearity
- Auto-overload protection prevents tweeter damage and resets automatically
- Solid protective grills and exceptionally rugged construction for long life and durability
- Brackets for wall/ceiling mounting are included

For stunningly accurate sound and stylish, neo-classic design, look to Behringer 1C-BK passive monitor speakers!

Tech Specs

Powered	No
LF Driver Size	5.5"
HF Driver Size	0.5"
Power Rating (Program)	25W
Peak Power Capacity	100W
Impedance	4 ohms
Frequency Range	60Hz-23kHz (-10dB)
Crossover Frequency	5000Hz
Maximum Peak SPL	112dB @ 1m



Control[®] 1 Pro

Two-Way Professional
Compact Loudspeaker
System

Professional Series

Key Features:

- ▶ 150 Watts Continuous Power Handling
- ▶ Professional Drivers and Crossover Network
- ▶ Included Mounting Bracket
- ▶ Transparent and Faithful Sonic Performance
- ▶ Magnetically Shielded Transducers
- ▶ SonicGuard™ Overload Protection
- ▶ Available in Black or White Finishes

Applications:

Representing the next-generation in professional high-performance, compact loudspeaker systems, the Control[®] 1 Pro builds on its proud heritage while incorporating the latest innovations in JBL Professional loudspeaker systems design. Featuring proven JBL transducer technologies, the Control 1 Pro is perfect for a wide variety of critical near-field audio applications.

With independent, monitor-grade high and low frequency drivers, the Control 1 Pro's professional crossover network provides steep slopes for exceptional sonic performance and incorporates full-range SonicGuard™ overload protection into the design ensuring network and transducer protection from excessive power surges from the amplifier.

The Control 1 Pro's rugged and durable molded enclosure houses magnetically shielded transducers making it ideal for use with video and computer monitors or other magnetically sensitive equipment. Moreover, the Control 1 Pro's compact design makes it ideal for audio-visual applications, computer workstations, recording and broadcast studios, mobile audio-video control rooms and foreground and background music.

The Control 1 Pro can easily be mounted against a wall or other flat surface with the enclosed brackets or simply used as a bookshelf speaker.



Specifications:

System:	Frequency Range (-10 dB): 80 Hz - 20 kHz
	Frequency Response (+/- 3 dB): 100 Hz - 18 kHz
	Power Capacity ¹ : 150 W
	Sensitivity ² : 87 dB SPL, 1 W 1 m (3.3 ft)
	Maximum SPL ³ : 108 dB continuous, 114 dB peak
	Directivity Factor (Q) ² : 6.0
	Directivity Index (DI): 7.8 dB
	Nominal Impedance: 4 ohms
	Crossover Frequency: 4.2 kHz
	Overload Protection: Full-range SonicGuard™ power limiting to protect network and transducers
Transducers:	LF Driver: 135 mm (5.25 in) low frequency loudspeaker
	HF Driver: 19 mm (.75 in) polycarbonate dome tweeter
	Input Connectors: Spring-loaded terminals
Enclosure:	Enclosure Material: Polypropylene Structural Foam
	Finish: Black (C1Pro) or White (C1Pro-WH)
	Dimensions: 235 mm x 159 mm x 143 mm (9.3 in x 6.3 in x 5.6 in)
	Net Weight (each): 1.8 kg (4 lb)
	Shipping Weight (pair): 4.6 kg (10 lb)
	Included Accessories: Mounting Bracket Assembly

¹IEC Standard, full bandwidth pink noise with 6 dB crest factor; 2 hour duration.

²Average 1 kHz to 10 kHz

³Calculated based on power rating and sensitivity, exclusive of power compression.

JBL continually engages in research related to product improvement. Some materials, production methods and design refinements are introduced into existing products without notice as a routine expression of that philosophy. For this reason, any current JBL product may differ in some respect from its published description, but will always equal or exceed the original design specifications unless otherwise stated.

► Control 1 Pro Two-Way Professional Compact Loudspeaker

Beamwidth:

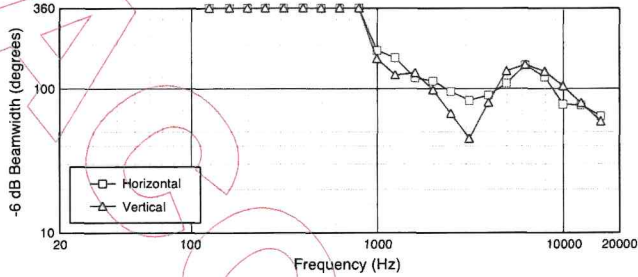

Directivity Index:

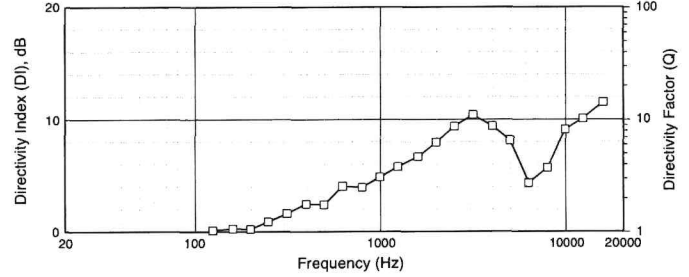

Frequency Response:

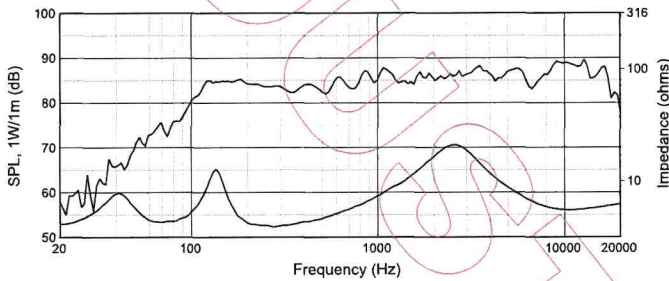

Horizontal Off-Axis Frequency Response:

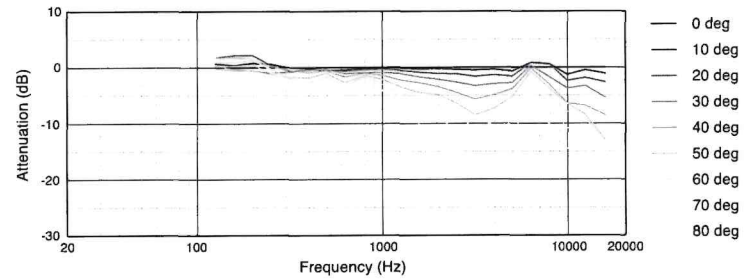

Dimensions:

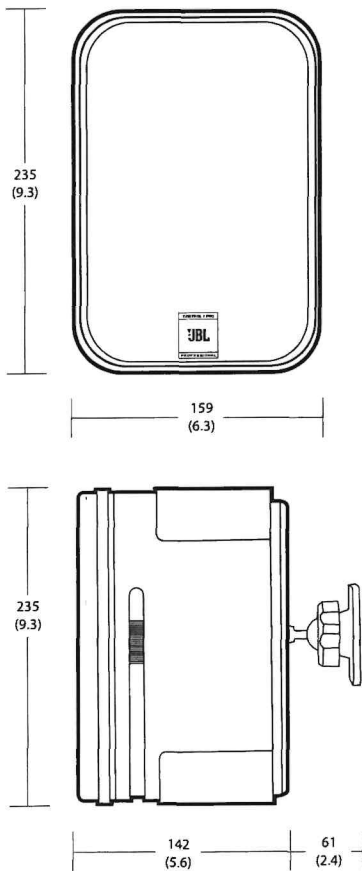

Dimensions in mm (in)

Mounting Bracket:

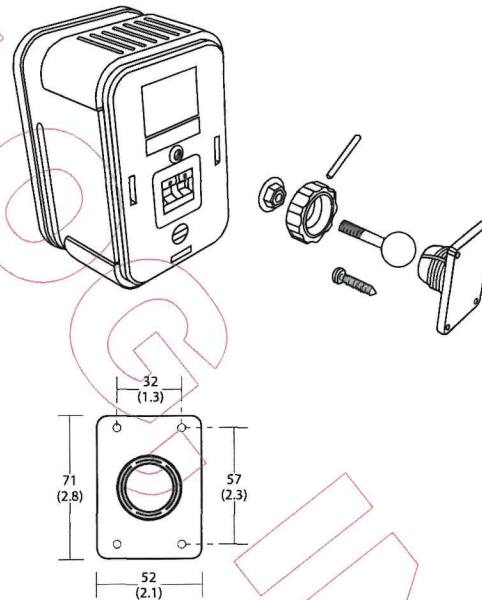

JBL Professional
8500 Balboa Boulevard, P.O. Box 2200
Northridge, California 91329 U.S.A.

© Copyright 2014 JBL Professional
www.jblpro.com

SS C1P
CRP
03/14

NS-AW150 Outdoor 2-way Speakers



4.4 21 Reviews | [Read Reviews](#)

\$129.95 PR.

FREE Shipping - [Learn More](#)

NS-AW150 Black – Available



Select a color/finish above.

NS-AW150 Black



Overview

Specs

Downloads

Product Information

NS-AW150 Outdoor 2-way Speakers

All-weather speaker system with wide frequency response.

- 5" High Compliance Polypropylene Mica Filled Woofer
- 1/2" PEI Dome Tweeter
- Wide Frequency Response (55 Hz-40 kHz)
- 120 W Maximum Input
- Wall Mounting Bracket Included
- Vertical or Horizontal Placement
- 5-way Binding Post Speaker

PHONE, MIXER
OR OTHER
SOUND SOURCE

EQUALIZER

LIMITER
(STEREO)

AMPLIFIERS / AMPLIFIED
SPEAKERS
Volume controls on
maximum.

NOTE - LIMITER AND EQUALIZER
FUNCTIONS CAN BE COMBINED IN
ONE PROCESSOR

NOT TO SCALE. All Acoustilog,
Inc.-designed information supplied
is for the original client and may
not be copied in any way for
different projects by any architect,
consultant, engineer or other party.
Copyright Acoustilog, Inc. © 2022.
All rights reserved. No reproduction
of any type permitted without
written permission of Acoustilog,
Inc.

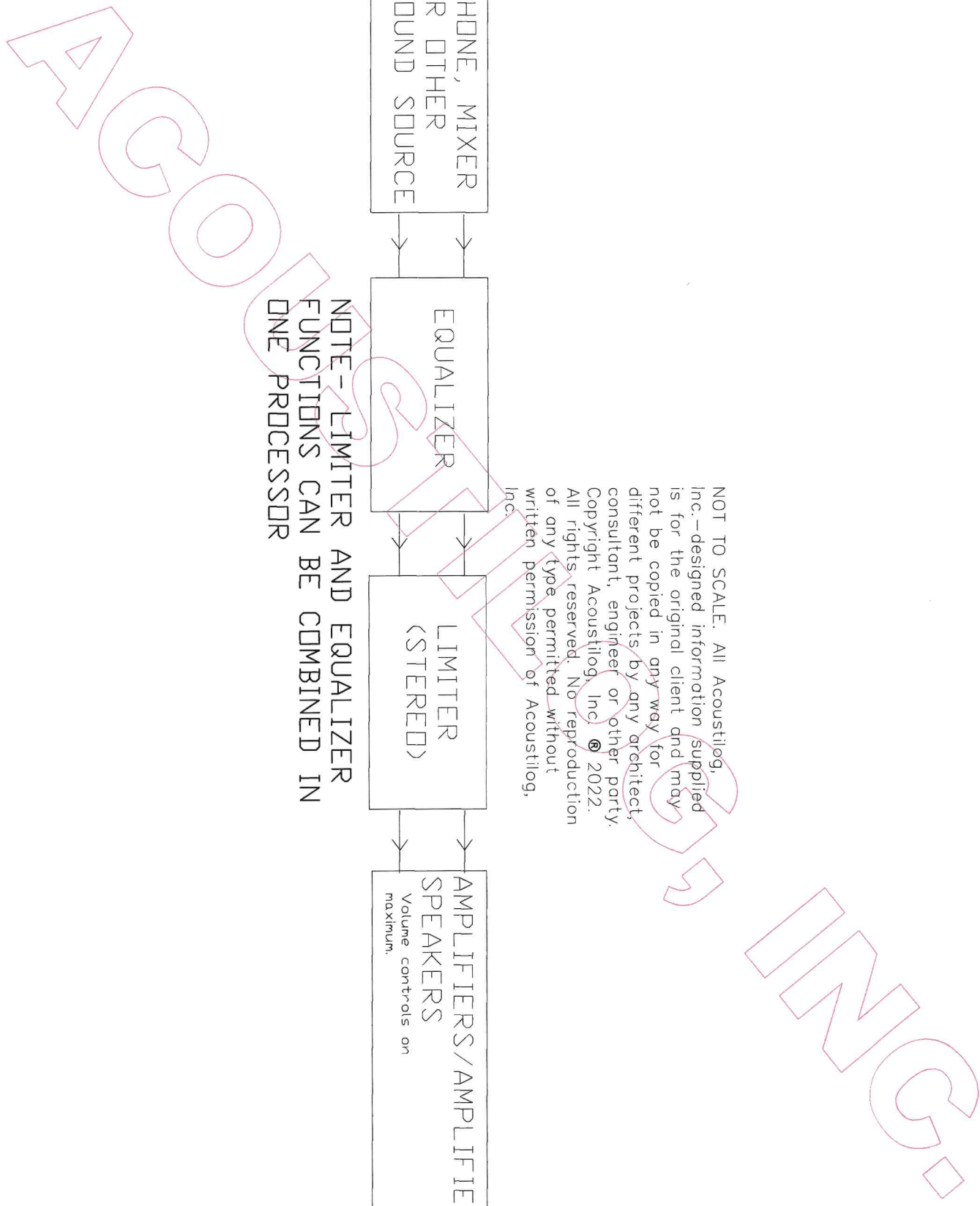



Larger Images

ALL YOU NEED TO GET THE MOST FROM YOUR PA. NOW WITH COMPLETE CONTROL FROM YOUR MOBILE DEVICE.

The DriveRack® PA2 provides all the processing you need between your mixer and amplifiers to optimize and protect your loudspeakers. With the latest advancements in dbx's proprietary AutoEQ™ and AFS™ algorithms, a new input delay module for delaying the FOH system to the backline, Ethernet control via an Android®, iOS®, Mac®, or Windows® device, and updated Wizards, the DriveRack PA2 continues the DriveRack legacy of great-sounding, powerful, and affordable loudspeaker management processors, for a whole new generation.

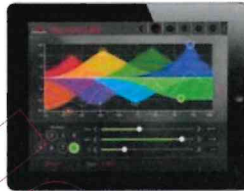

Control your PA2 major DSPs

AUTOEQ™

New, improved AutoEQ algorithm ensures an extremely accurate, fast, and non-intrusive automatic EQ experience.

With the RTA Mic "listening" to your room, the new, updated DriveRack PA2 AutoEQ algorithm sets speaker levels and room EQ automatically in a matter of seconds. This means room adjustments can now be made very quickly, without subjecting the audience to annoying, lengthy broadcasts of pink noise.

ENHANCED AFS™ FEEDBACK ELIMINATION

Enhanced AFS™ algorithm for faster, more precise feedback elimination, without adversely affecting your system's tone.

Nothing turns audiences away like annoying and potentially painful audio feedback. Fortunately, dbx engineers have revisited their already-stellar Advanced Feedback Suppression algorithm and made it work even better. The DriveRack PA2 listens for and anticipates feedback and adjusts speaker output automatically before it even has a chance, while never altering your sound.

UPDATED WIZARD SETUP FUNCTIONS

Updated Wizards make initial set up easy, while ensuring speaker tunings and other settings are up-to-date.

Wizard functions on the DriveRack PA2 guide you through easy, step-by-step processes to help you get the most from your loudspeaker system. Helps you easily configure level balancing, AutoEQ, Advanced Feedback Suppression, and provides access to built-in and constantly updating speaker tunings from most major speaker manufacturers.

AVAILABLE INPUT PROCESSING

- › dbx Compression
- › AFS™ (Advanced Feedback Suppression)
- › Graphic EQ
- › 8-Band Parametric EQ (adjusted when using the AutoEQ)
- › Subharmonic Synthesis

AVAILABLE OUTPUT PROCESSING

- › Crossover (supports full range, 2-way, and 3-way systems)
- › 8-Band Parametric EQs (used for speaker tunings)
- › dbx Limiting
- › Driver Alignment Delays

DriveRack PA2

Complete Loudspeaker Management System

MSRP ~~\$624.99~~
\$399.95
 SAVE \$224.99!

Buy It Now

OVERVIEW

2018-11-15
 10:00 AM
 10:00 AM
 10:00 AM
 10:00 AM
 10:00 AM
 10:00 AM
 10:00 AM
 10:00 AM

Like Tweet

Features

- › All New Setup Wizard
- › Streamlined AutoEQ™
- › All New AFS™ (Advanced Feedback Suppression)
- › Mobile Control (Android®, iOS®, Mac®, Windows®)
- › dbx Compression
- › Graphic EQ
- › 8-Band Parametric EQ (adjusted when using the AutoEQ) Input
- › Subharmonic Synthesis
- › Crossover (supports full range, 2-way, and 3-way systems)
- › 8-Band Parametric EQs (used for speaker tunings) Output
- › dbx Limiting
- › Driver Alignment Delays

ACOUSTILOG® www.acoustilog.com

19 Mercer Street, New York, NY 10013 (212) 925-1365 acoustilog1@verizon.net



Push the RESPONSE button if necessary so that it says "Slow" on the display. It should retain that setting from the last time it was used.

Don't use these 2 buttons.

Push the red button to turn it on and off. I put this protection ring around it because it is easy for it to be accidentally turned on – and you would have a dead battery next time if it was left on accidentally.

Push the A/C button if necessary so that it says "C" on the display. It should retain that setting from the last time it was used.

Diagram

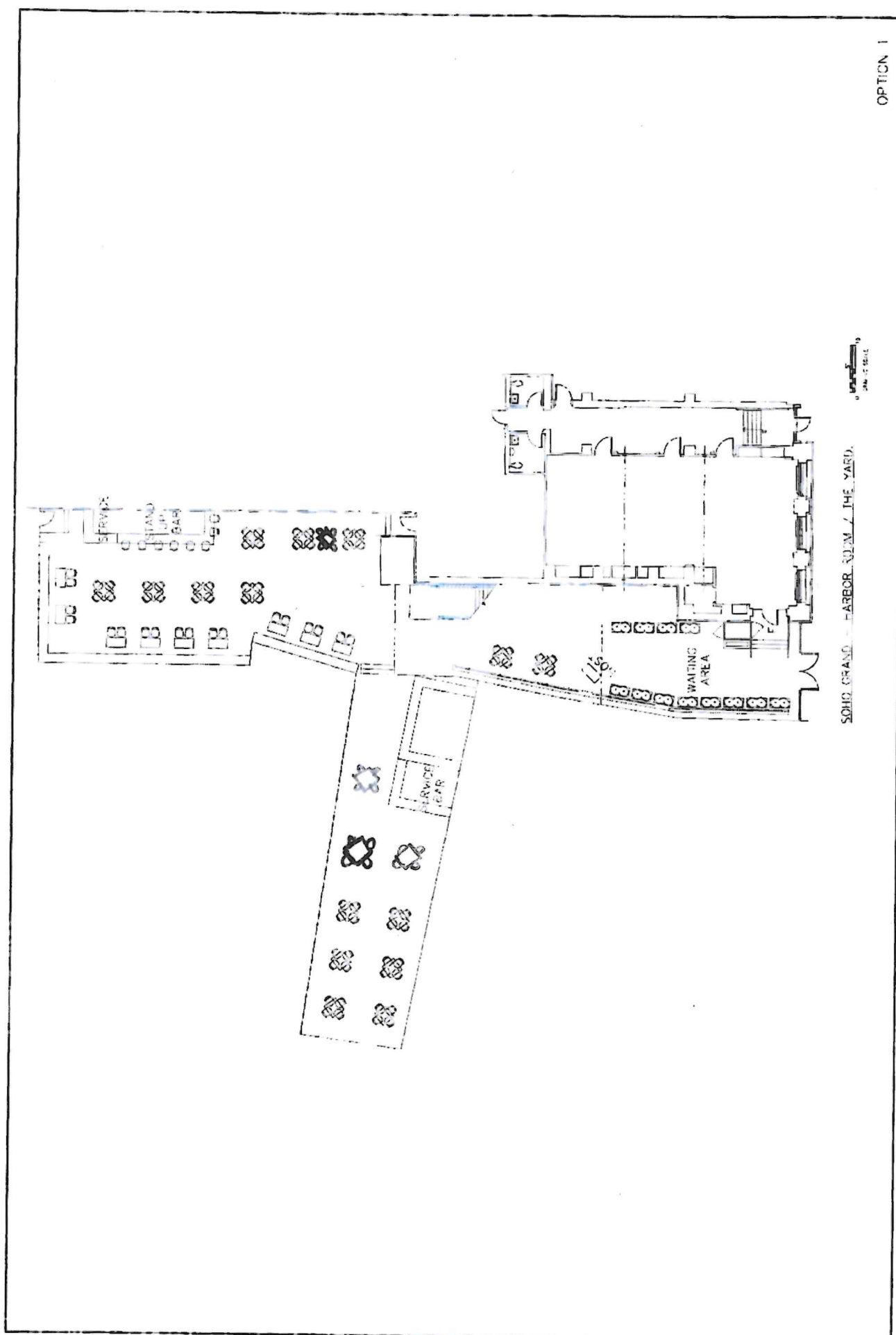

SOHO GRAND HARBOUR NO. 1 THE YARD.

OPTION 1

SCALE

Menu

GILLIGAN'S

EAST COAST OYSTERS

dressed with
white balsamic mignonette
24 // 48



CRUDO

east end tuna, salmon, fluke
capers, lemon oil 26

SHRIMP COCKTAIL

grilled, chilled jumbo shrimp
spicy cocktail sauce 22

Fare to Share

*Sotto's best catches,
by land and sea*

ROASTED CORN RIBS
chili mayo
crumbled feta
shaved scallions 16

SMASHED AVOCADO
house pita, olive oil
sea salt 18

LOCAL BURRATA
pickled peaches
chili crunch
grilled baguette 18

CRAB & ARTICHOKE DIP
black olives
roasted tomato
everything lavash 21

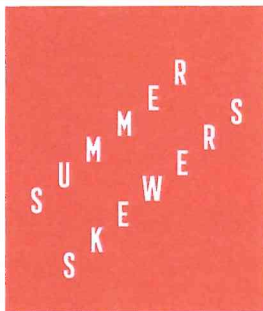

GRILLED HALLOUMI — sesame & hot honey	15
BABY SUMMER VEGETABLES — vadouvan aioli	16
CHIMICHURRI CHICKEN — charred shishito pepper	16
SMOKY BEEF & SPRING ONION — hazelnut romesco	20

BABY ROMAINE CAESAR

garlic croutons
white anchovy
aged parmesan 19

GRILLED FISH TACOS

marinated mahi mahi
mango habanero salsa
chili lime mayo 24

MAINE LOBSTER ROLL

lemon-brown butter aioli
potato chips 36

SPINACH & RICOTTA RAVIOLI

raw sungold tomato
garlic crumble 24

PIZZA

SQUASH BLOSSOM
house made ricotta
baby zucchini
basil pesto 24

MARGHERITA
fresh mozzarella
fresh basil, tomato 24

SOPPRESSATA
spicy sausage
tomato, caciocavallo
pepperoncini 24

NICK'S IT ICE CREAM SANDWICH

morganstern's finest
ice cream
strawberry // banana
\$14



©GILLIGANSNYC

Join us for **HAPPY HOUR** Monday-Friday 3-6PM

Consuming Raw Or Undercooked Meats, Poultry, Seafood, Shellfish Or Eggs May Increase Your Risk Of Foodborne Illness. There is a 20% Service Charge for Parties of 6 or More.

Cocktails

HONEY DEUCE

Grey Goose, lemonade
raspberry liqueur 18

THE HAMPTONITE

vodka, elderflower
mint, hibiscus, ginger 18

SEVEN DAY WEEKEND

bourbon, mango
kalani coconut liqueur
lemon 18

THE LAZY SUNBATHER

gin, campari, basil
strawberry
sweet vermouth 18

SPICY SKIPPER

jalapeño infused blanco
tequila, mezcal, lime
pineapple, cilantro, agave 16

CASA MARGARITA

casamigos reposado tequila
tamarind, agave nectar
lime 22

Beer

Montauk Pilsner 9 / 45
Sloop Juice Bomb IPA 10 / 50
Sunday Light 8 / 40
Oxbow Surfcasting 10 / 50

Non-Alcoholic — Best Day Brewing Kolsch 10

Non-Alcoholic — Good Time IPA 10

6 BOTTLES PER BUCKET

LIMONCELLO PIÑA COLADA

limoncello, white rum
lemon, pineapple
coconut
20

FROZEN

FROZEN WATERMELON MARGARITA

tequila, fresh watermelon
triple sec, lime
18



WINE

ROSE	Maison Noir "Love Drunk Rose", OR '24	16 / 72
	Stoller Family Estate, OR '24	18 / 80
	Cht. Minuty "Rose et Or", FR '24	24 / 108 / 220
	Arnot-Roberts, CA '22	90
WHITE	Chardonnay, Mas la Chevaliere "Le Petit ", FR '22	16 / 72
	Pinot Grigio, Cora Colline Pescaresi, IT '24	16 / 72
	Sauvignon Blanc, Pascal Jolivet "Attitude, FR '24	24 / 108
BUBBLES	Cava CVNE "Cune", SP NV	16 / 72
	Rose Crémant d'Alsace, Pierre Sparr, FR NV	22 / 100
ORANGE	Azimut Penedes "Brisat", Orange, SP '24	18 / 80
RED	Pinot Noir, Sean Minor California Series, CA '22	18 / 80
	Nebbiolo, Serio e Batista Borgogno, IT '21	24 / 108

ZERO BUZZ

Watermelon Spritz
ghia na aperitif, watermelon
lime, seltzer

Keep It Reel
martini rossi floreale aperitif
apple, ginger, lemon, seltzer

16

H
A
P
P
Y

GILLIGAN'S

HAPPY HOUR *Monday-Friday 3-6PM*

EAST COAST OYSTERS

dressed with
white balsamic mignonette

| 2 |



PIZZA

SQUASH BLOSSOM

house made ricotta
baby zucchini
basil pesto 12

MARGHERITA

fresh mozzarella
fresh basil, tomato 12

SOPPRESSATA

spicy sausage
tomato, caciocavallo
pepperoncini 12

THE

HAMPTONITE

vodka, elderflower
mint, hibiscus, ginger 12

SPICY SKIPPER

jalapeño infused blanco
tequila, mezcal, lime
pineapple, cilantro
agave 12

Cava 12 — House White 12 — House Rosé 12

Montauk Pilsner 6

H
O
U
R

Photographs

Entrance doors

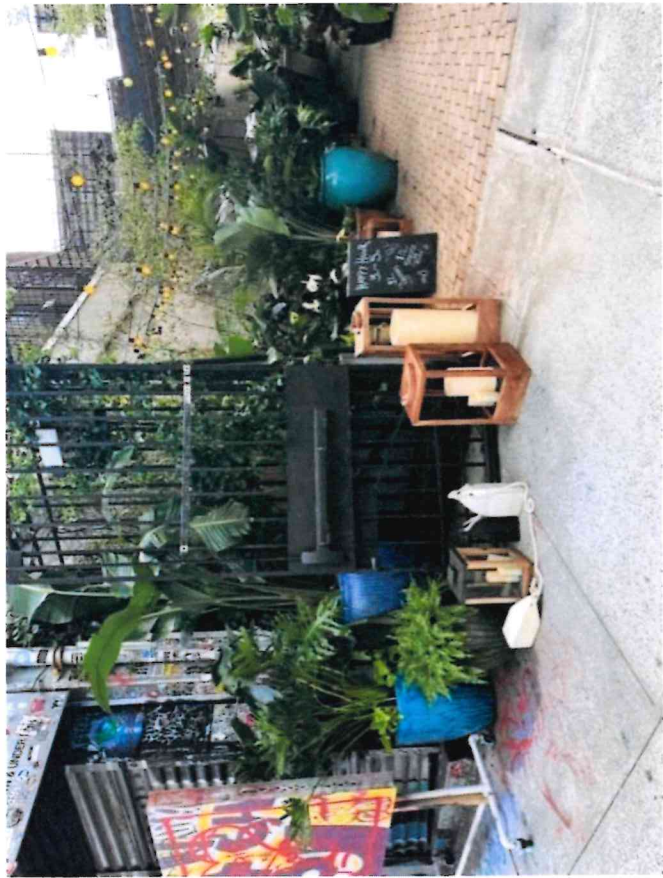
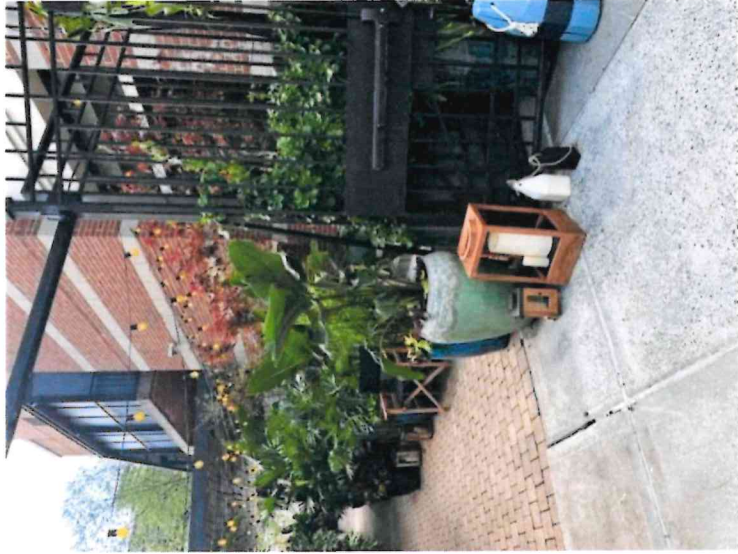

Entryway

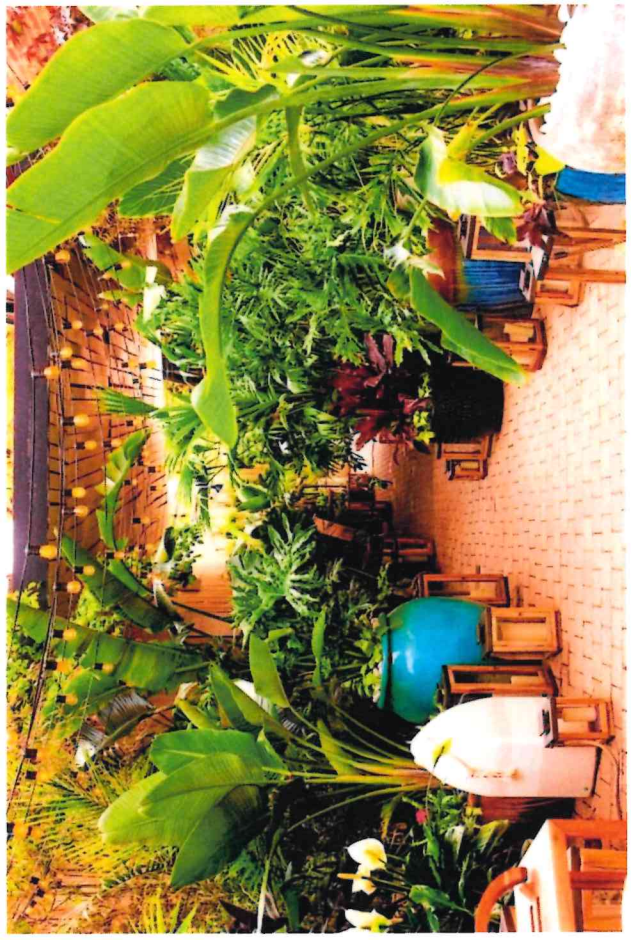

Oyster deck banquette



Oyster deck banquette



Oyster deck – low tables



Main Area - Pergola



Main Area - Pergola



Main Area banquette



Existing CB2 Stipulations

Tobi Bergman, Chair
Terri Cude, First Vice Chair
Susan Kent, Second Vice Chair
Bob Gormley, District Manager



Antony Wong, Treasurer
Keen Berger, Secretary
Susan Wittenberg, Assistant Secretary

COMMUNITY BOARD NO. 2, MANHATTAN

3 WASHINGTON SQUARE VILLAGE
NEW YORK, NY 10012-1899

www.cb2manhattan.org

P: 212-979-2272 F: 212-254-5102 E: info@cb2manhattan.org

Greenwich Village • Little Italy • SoHo • NoHo • Hudson Square • Chinatown • Gansevoort Market

I, TONY FAAT, as a qualified representative of Soho Grand Hotel located at 310 West Broadway NY, NY 10013 ("the Hotel") hereby agrees to request that all of the restrictions listed herein be made a condition of any license issued by the New York State Liquor Authority (SLA) in connection with its existing Hotel On Premise license (#102330) and that the following stipulations, which relate to use of the side yard located on the ground floor of the South Side of the Hotel, be incorporated into the Hotel On Premise Liquor Licensee as follows:

1. The Hotel will not permit any patron use in or about the covered second floor landing and covered staircase on the south side of the Hotel which leads from a set of emergency exit doors on the second floor (Club Bar) down to the ground floor of the side yard except in the case of an emergency. The Hotel will also not permit any staff use or operation of this staircase for the purpose of serving Hotel patrons; however, Hotel staff may access this staircase as may be necessary to maintain or repair the Hotel or for any Hotel operations (other than to serve patrons) or in the case of an emergency.
2. The Hotel will not permit patrons to enter or exit the exterior doors located in the Club Room leading to the above-referenced covered second floor landing and staircase located on the south side of the Hotel's second floor except for emergency egress (ie. fire, natural disaster or criminal act) and will not permit patrons on the exterior landing itself.
3. The Hotel has presented an amended diagram (Exhibit "A") for the use of side yard that designates the location of all tables, one service station and one stand-up only, the stand-up bar being located on the far western side of the yard to ameliorate noise impacts on neighbors located on the eastern side of the yard, there will be 19 tables with 4 seats, an additional 9 tables with 2 seats and 10 seats at the stand-up bar, for a total of 104 seats.
4. The Hotel will only provide service of alcohol to patrons seated among the 104 table seats or additional patrons (up to the allowable maximum occupancy) at the bar and will use efforts to prevent crowds of patrons from congregating in one location to reduce noise levels, and there will only be food service from the interior Hotel to the outdoor tables located in the side yard.
5. There will be no music played or speakers installed outside.
6. There will be no service of alcohol on the eastern side of the yard designated as the "Waiting Area" in Exhibit "A" which area is shown as the space between the gate on West

Broadway and the Host Station and the Hotel will continue to maintain the cover over the eastern side of the yard.

7. The exterior gate and entrance/exit on West Broadway will not be open until Noon on Sundays and will be closed every night at 10 PM, the side yard will be closed from Sunday through Thursday at 10 PM and close on Fridays and Saturday nights at 11 PM, all business will cease, no loitering, no smoking, and there will be no patrons remaining after closing and the lights will be turned off within a reasonable time after closing.

8. There will be two bathrooms installed on the interior to accommodate all patrons to the side yard.

9. The Hotel will not open the outdoor side yard for patron use in any manner until it has obtained a temporary or final certificate of occupancy from the New York City Department of Buildings permitting such use.

There are be no other outdoor uses requested in this alteration application other than what has been described in this two page stipulation agreement with CB2 Manhattan and Exhibit "A".

Name: TONY FANT Phone Number: [REDACTED]

Signed [Signature]
Sworn to this 21 day of May 2015

Dated 5/21/15
Stephany Londono

Notary Public

Community Board #2, Manhattan and the above referenced Licensee request that the SLA incorporate the stipulations above in to the liquor license for Soho Grand Hotel

STEPHANY LONDONO
Notary Public, State of New York
Registration #01LO6299036
Qualified In Queens County
Commission Expires March 17, 2018