



01 1940'S TAX PHOTO



02 EXISTING BUILDING

SHEET INDEX

- 01\_TITLE SHEET
- 02\_HISTORIC DISTRICT MAP
- 03\_EXISTING CONDITION PHOTOS
- 04\_DIAGRAMS
- 05\_AREA PLAN - REAR YARD CELLAR
- 06\_AREA PLAN - REAR YARD FIRST FLOOR
- 07\_SECTIONS
- 08\_SECTIONS
- 09\_AREA PLAN APPROVED
- 10\_SECTIONS APPROVED
- 11\_FRONT GATE AND FENCE EXISTING CONDITION AND PROPOSED DESIGN
- 12\_FRONT GATE AND FENCE PROPOSED DESIGN DETAILS
- 13\_FRONT GATE AND FENCE - PHOTO DOCUMENTATION FROM THE AREA

122 WAVERLY PLACE  
 REAR YARD EXCAVATION  
 DHD ARCHITECTURE PC  
 SARA KOSTIC AND LARISSA JIMENEZ  
 06/15/2023  
 SLIDE 01



03 PLOT PLAN

Greenwich Village Historic District Extension | LP-2184

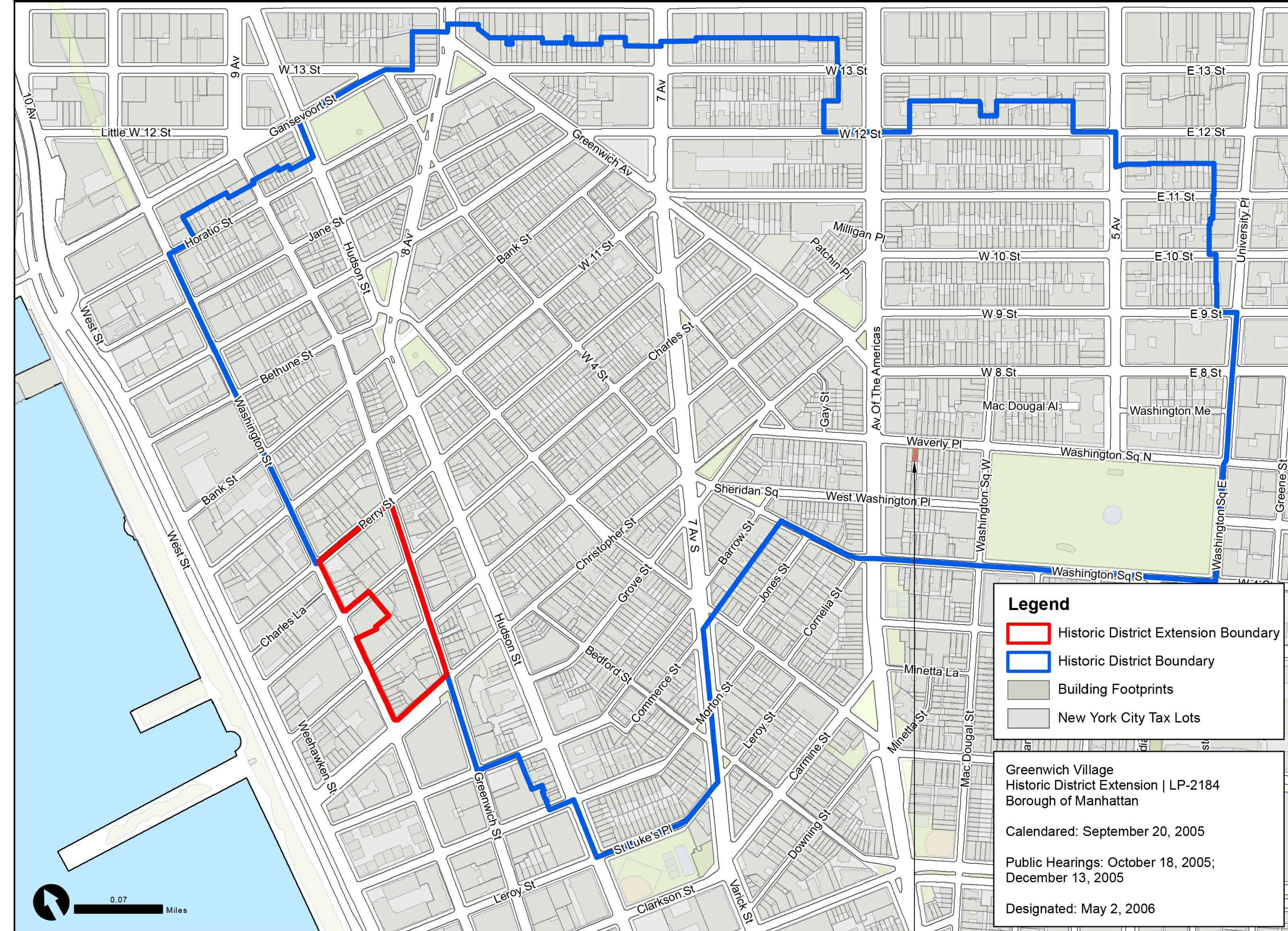

122 WAVERLY PLACE  
 REAR YARD EXCAVATION  
 DHD ARCHITECTURE PC  
 SARA KOSTIC AND LARISSA JIMENEZ  
 06/15/2023  
 SLIDE 02

**Legend**

- ▭ Historic District Extension Boundary
- ▭ Historic District Boundary
- ▭ Building Footprints
- ▭ New York City Tax Lots

Greenwich Village  
 Historic District Extension | LP-2184  
 Borough of Manhattan  
 Calendared: September 20, 2005  
 Public Hearings: October 18, 2005;  
 December 13, 2005  
 Designated: May 2, 2006

Graphic Source: Map PLUTO, Edition 18v1, Author: New York City Landmarks Preservation Commission, LCR Date: 2.20.2019

122 WAVERLY PLACE

01 GREENWICH VILLAGE HISTORIC DISTRICT MAP

02 ENLARGED GREENWICH VILLAGE HISTORIC DISTRICT MAP

KEY MAP

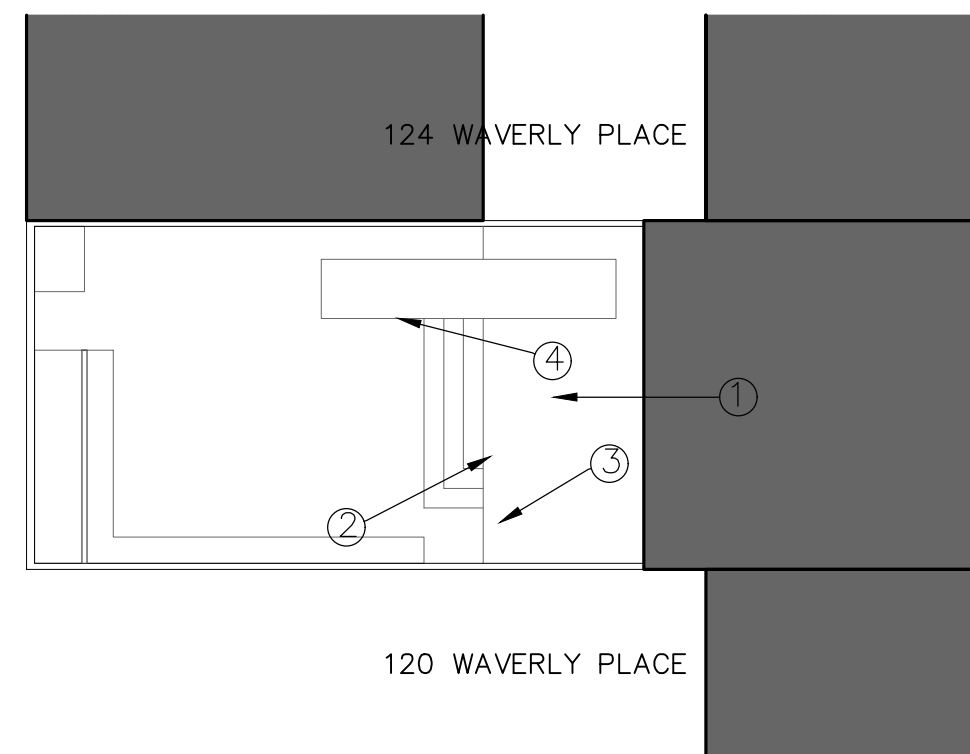

① REAR YARD PHOTO



② REAR YARD PHOTO

122 WAVERLY PLACE  
REAR YARD EXCAVATION  
DHD ARCHITECTURE PC  
SARA KOSTIC AND LARISSA JIMENEZ  
06/15/2023

SLIDE 03



③ REAR YARD PHOTO

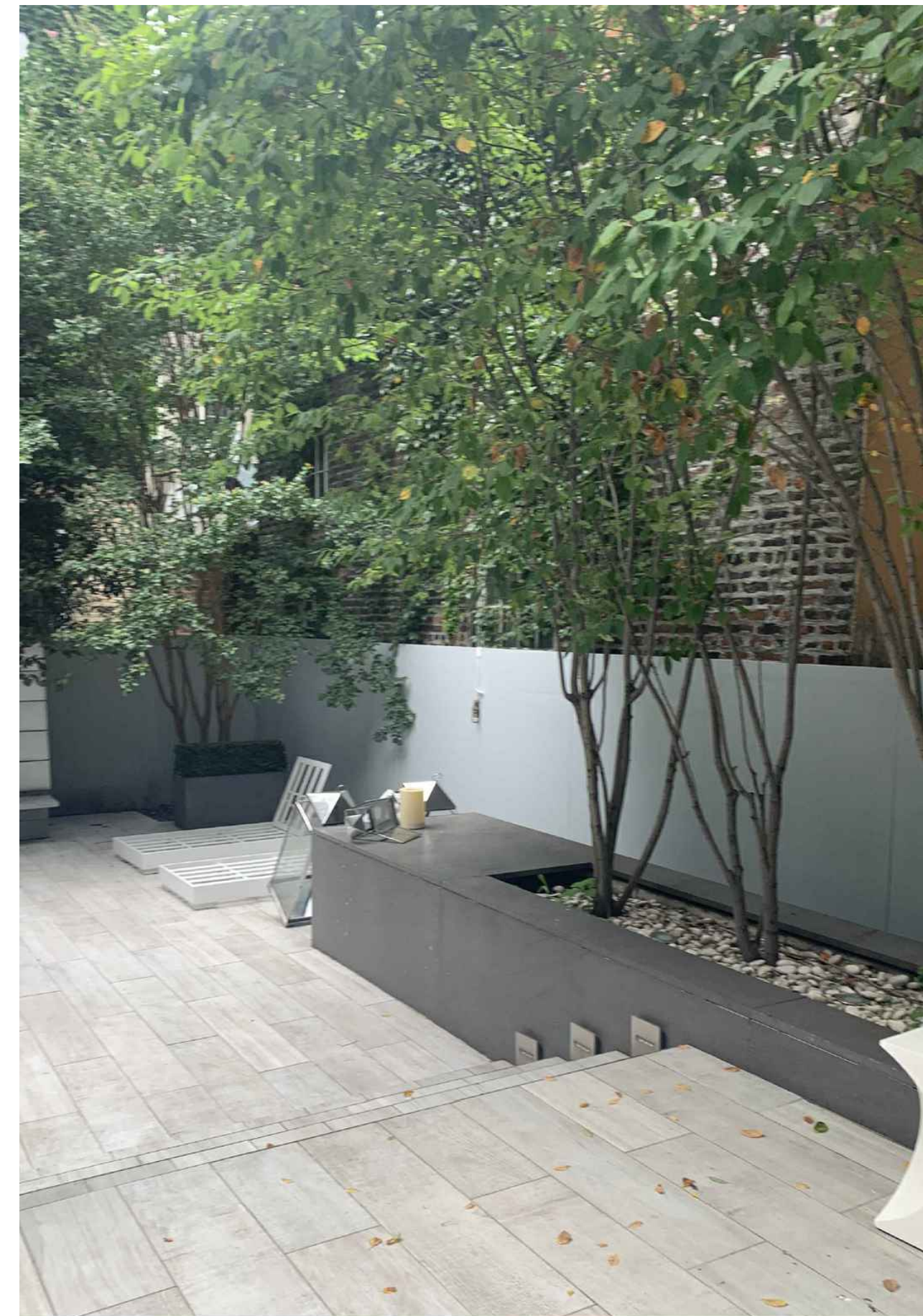

④ REAR YARD PHOTO

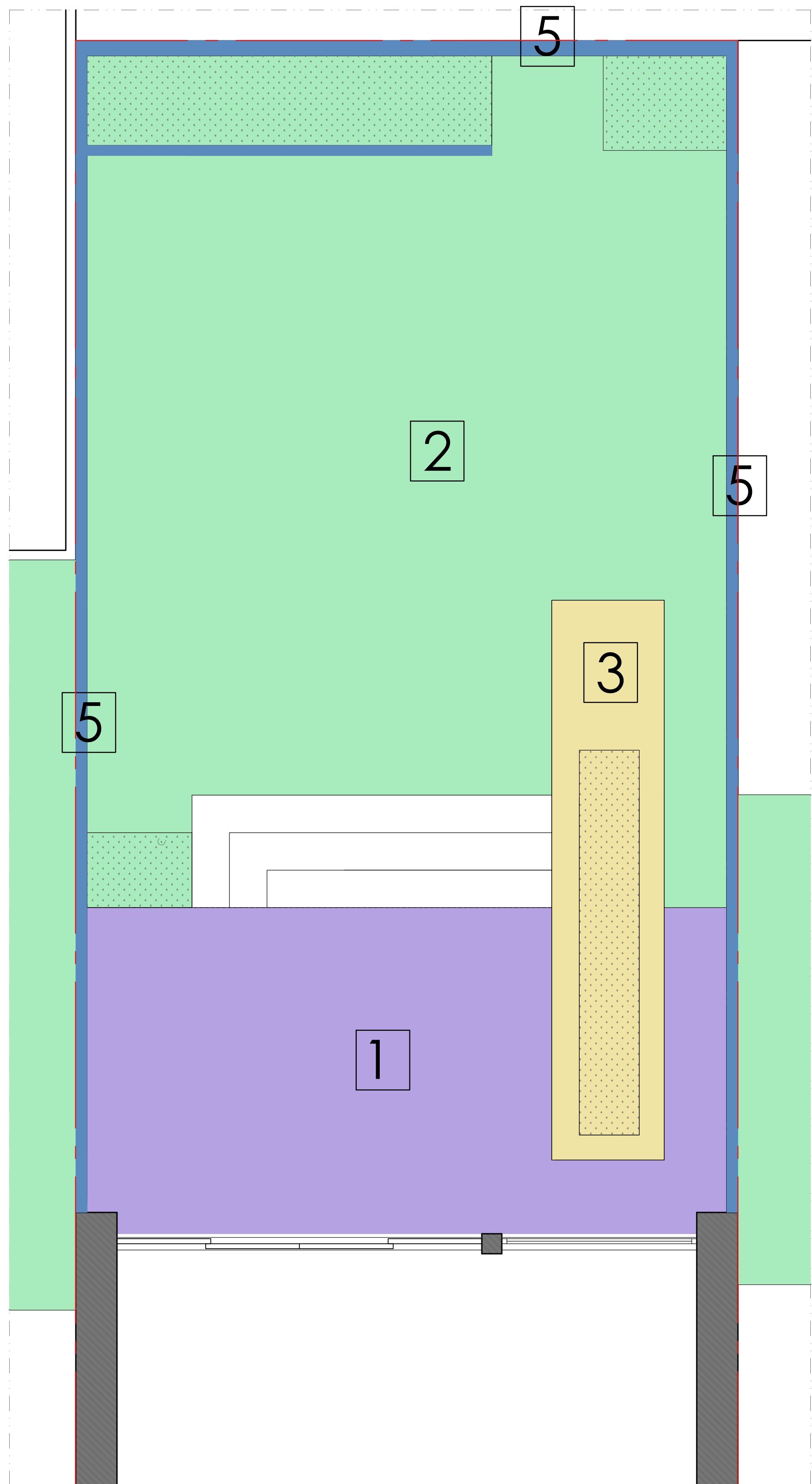

01 DIAGRAM GRADE RELATIONSHIP - EXISTING  
 3/8"-1'0"

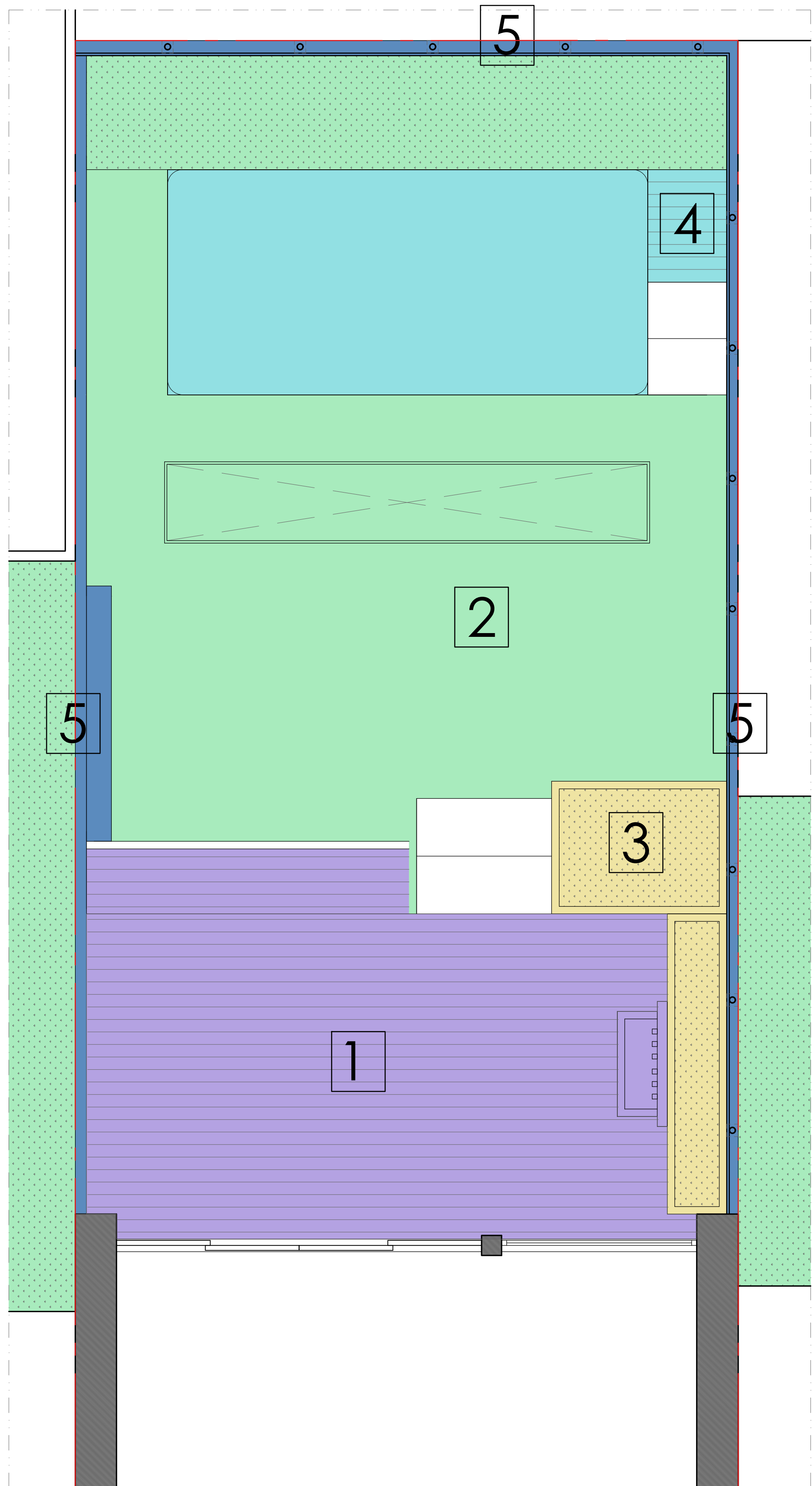

02 DIAGRAM GRADE RELATIONSHIP - PROPOSED  
 3/8"-1'0"

LEGEND

- 1-HIGHER PATIO (0.00)
- 2-LOWER PATIO (-1'-6")
- 3-PLANTER (+10")
- 4-TUB PATIO (+8")
- 5-FENCE (+4'-0")
- PROPERTY LINE

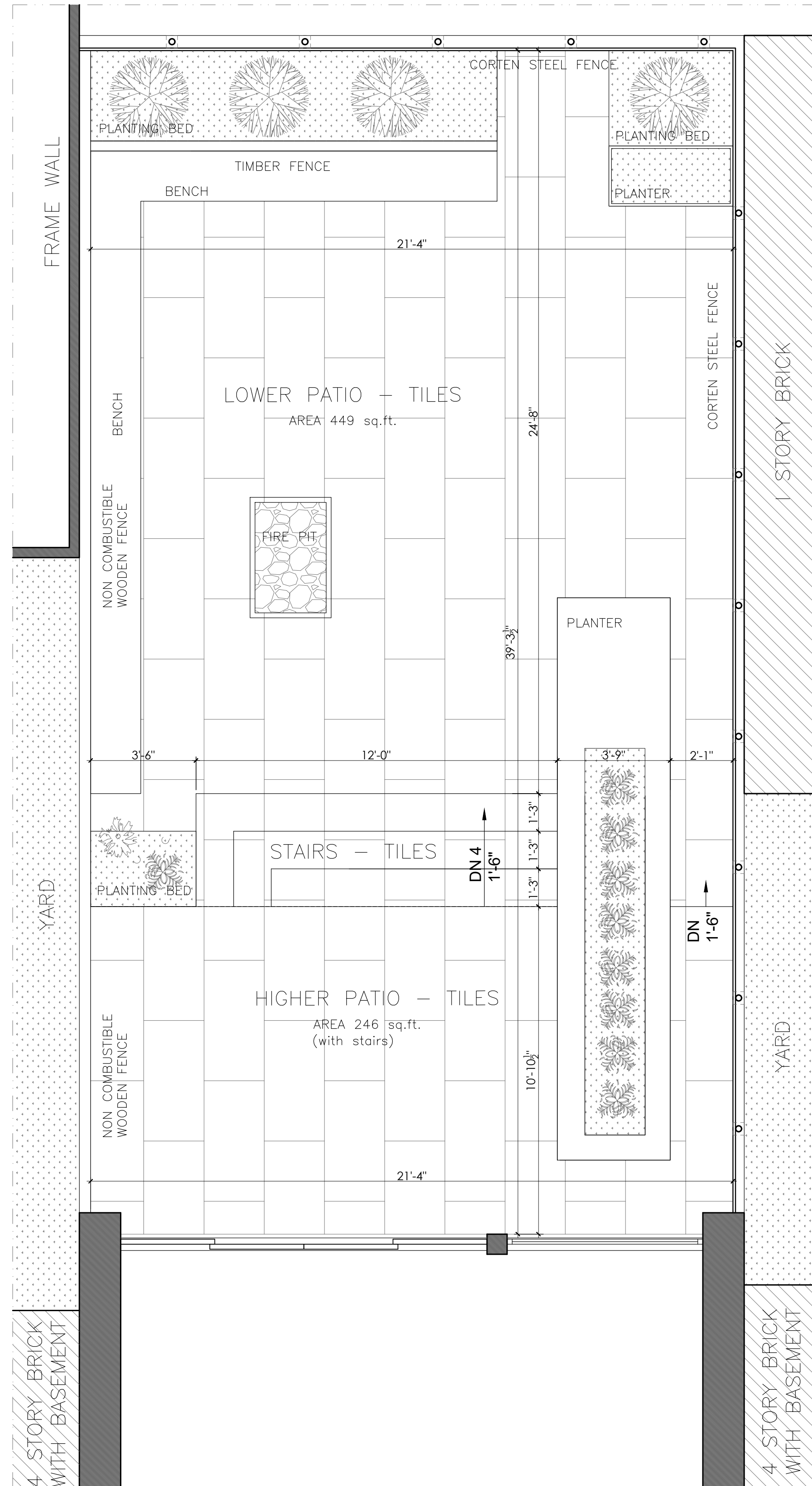

**01** AREA PLAN - REAR YARD FIRST FLOOR, EXISTING  
 3/8"=1'-0" LPC docket number #063313 - Approved Staff Level 2005

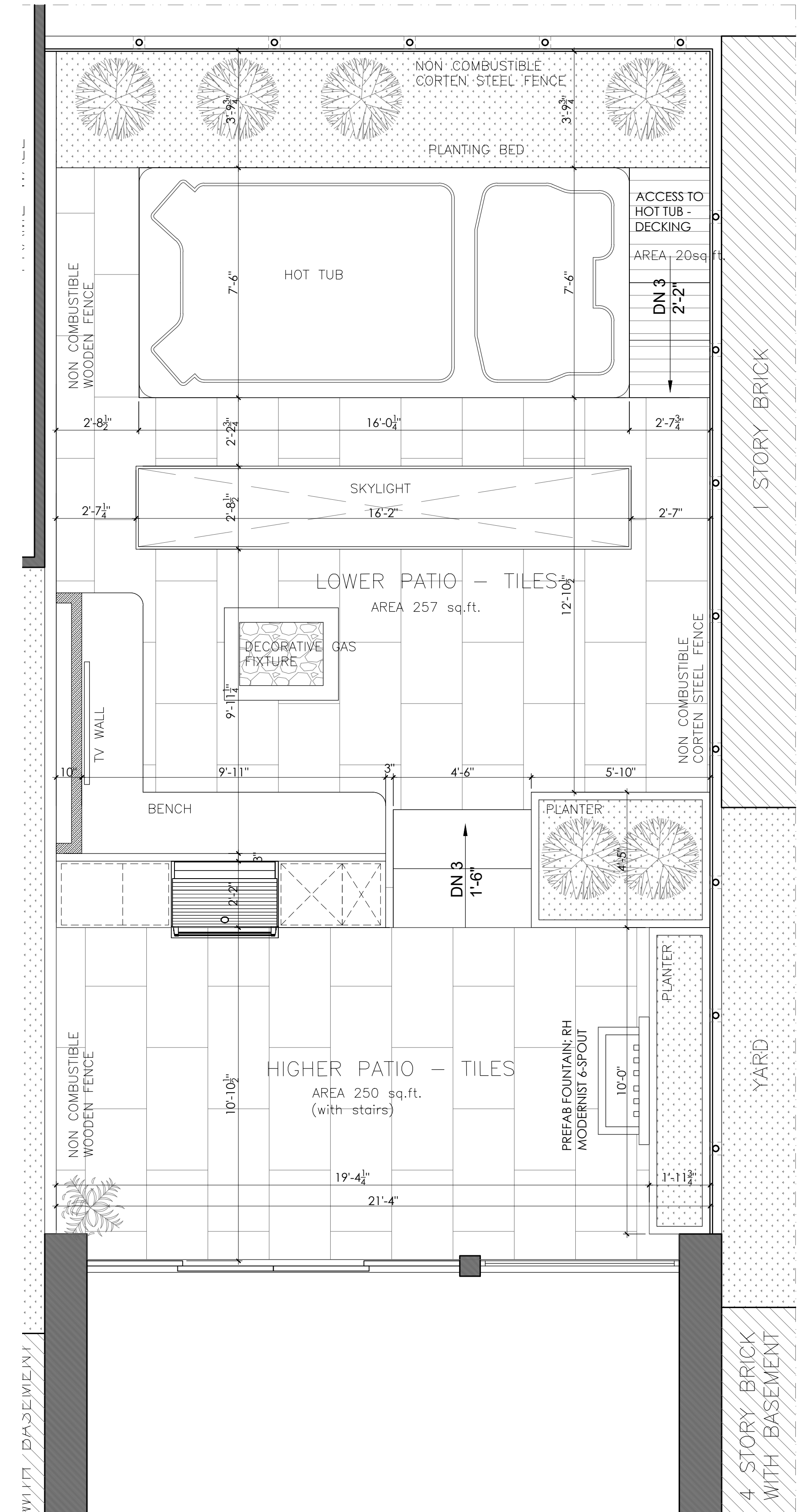
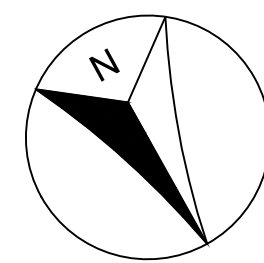

**02** AREA PLAN - REAR YARD FIRST FLOOR, PROPOSED  
 3/8"=1'-0"

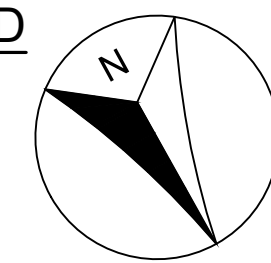

122 WAVERLY PLACE  
 REAR YARD EXCAVATION  
 DHD ARCHITECTURE PC  
 SARA KOSTIC AND LARISSA JIMENEZ  
 06/15/2023  
 LPC  
 SLIDE 05

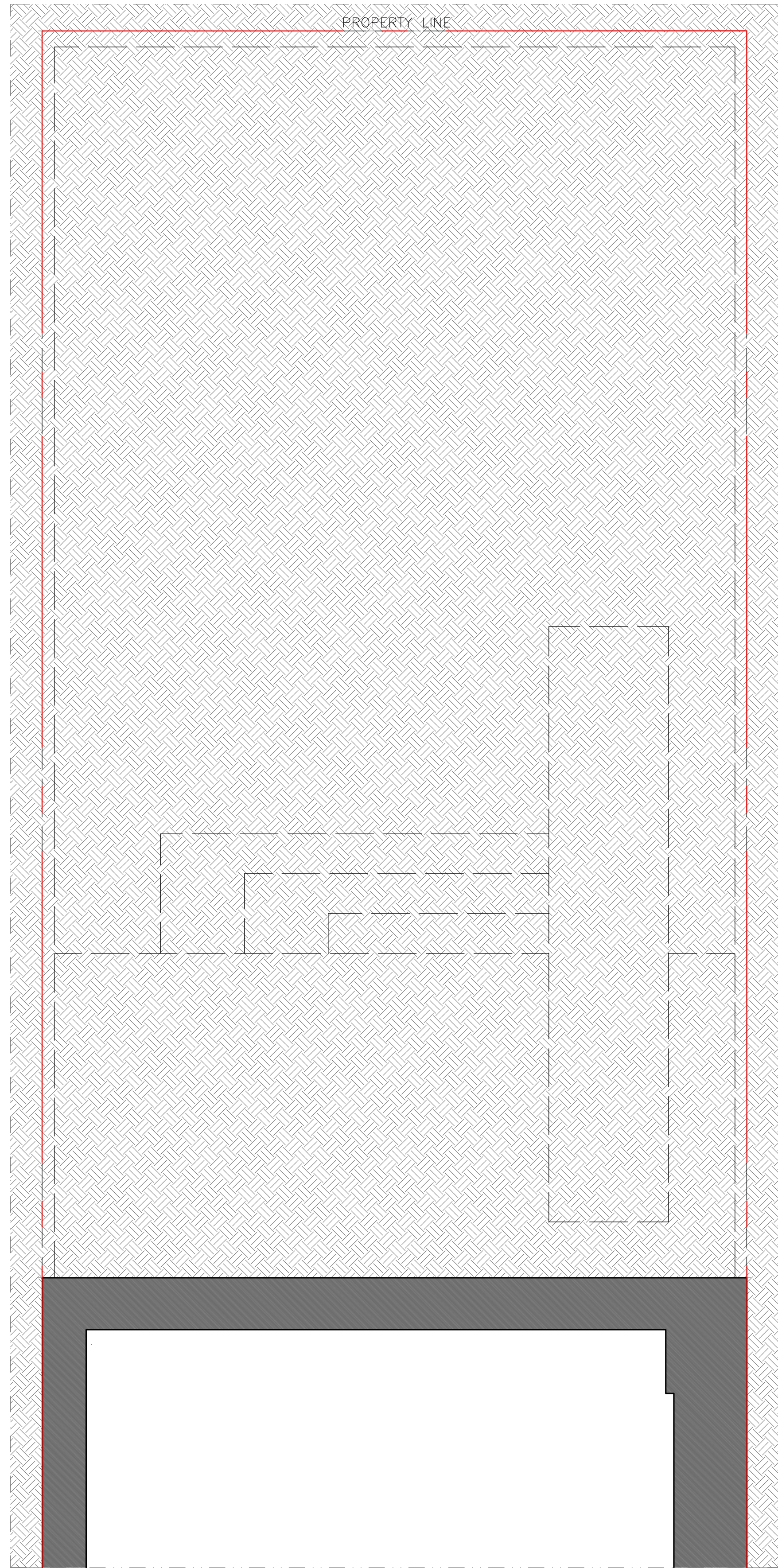

01 AREA PLAN - REAR YARD CELLAR, EXISTING  
3/8"-1'-0"

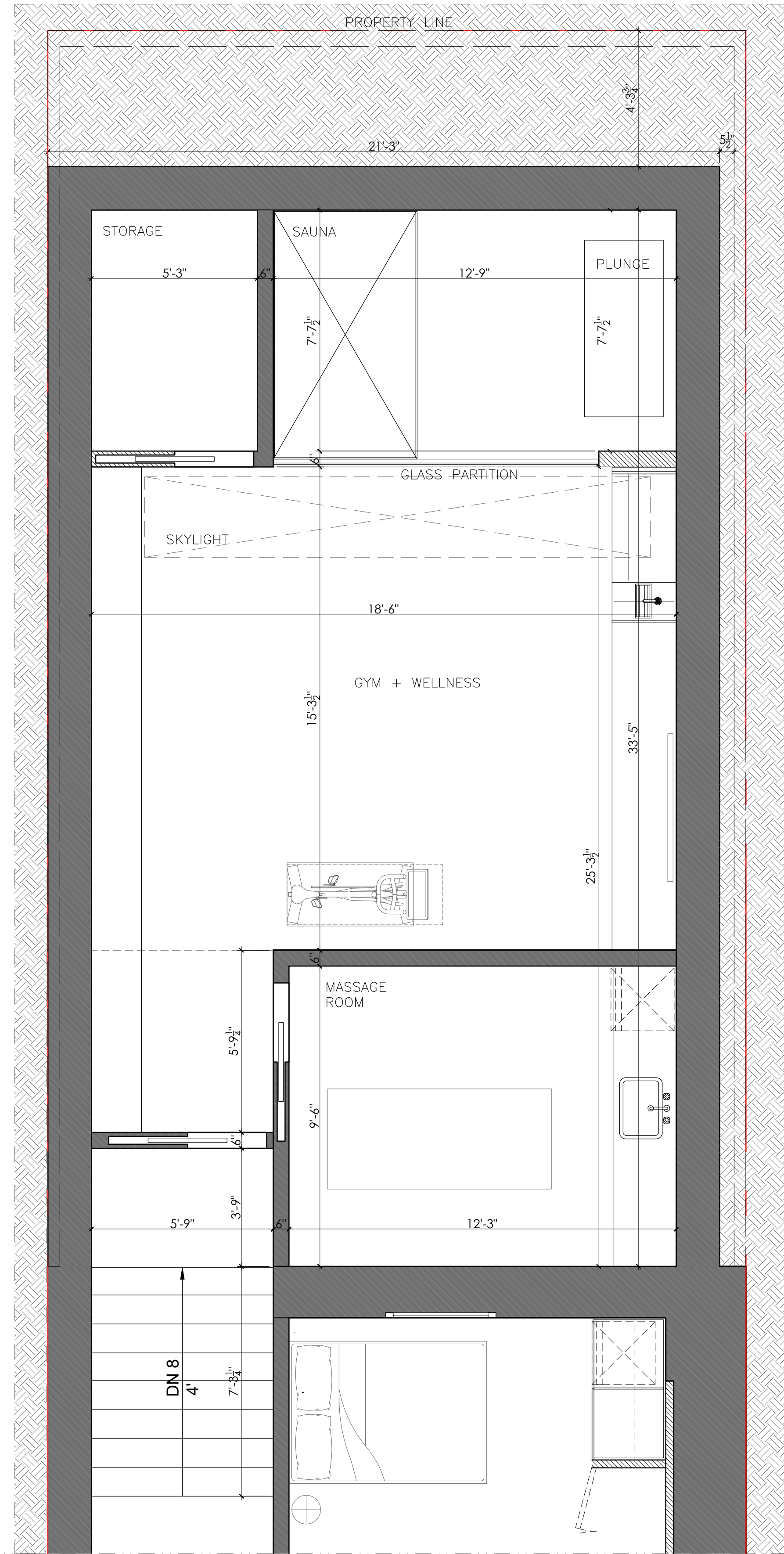
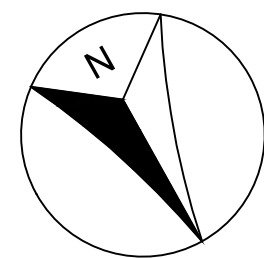

02 AREA PLAN - REAR YARD CELLAR, PROPOSED  
3/8"-1'-0"

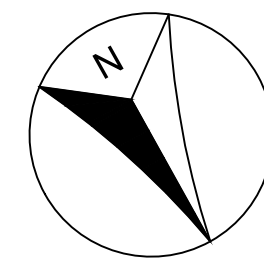

122 WAVERLY PLACE  
REAR YARD EXCAVATION  
DHD ARCHITECTURE PC  
SARA KOSTIC AND LARISSA JIMENEZ  
06/15/2023  
LPC  
SLIDE 11

122 WAVERLY PLACE  
 REAR YARD EXCAVATION  
 DHD ARCHITECTURE PC  
 SARA KOSTIC AND LARISSA JIMENEZ  
 06/15/2023  
 LPC  
 SLIDE 07

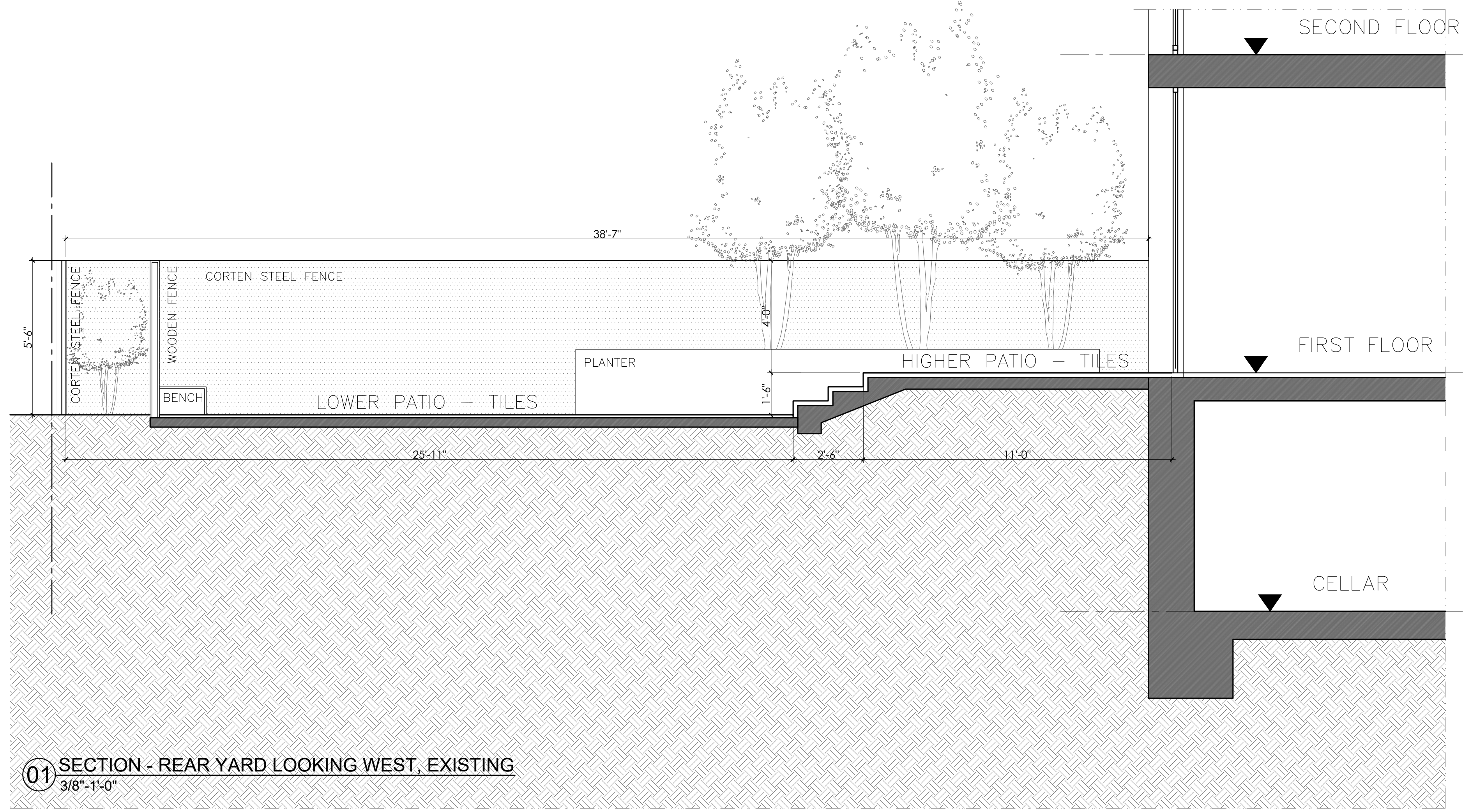

01 SECTION - REAR YARD LOOKING WEST, EXISTING  
 3/8" = 1'-0"

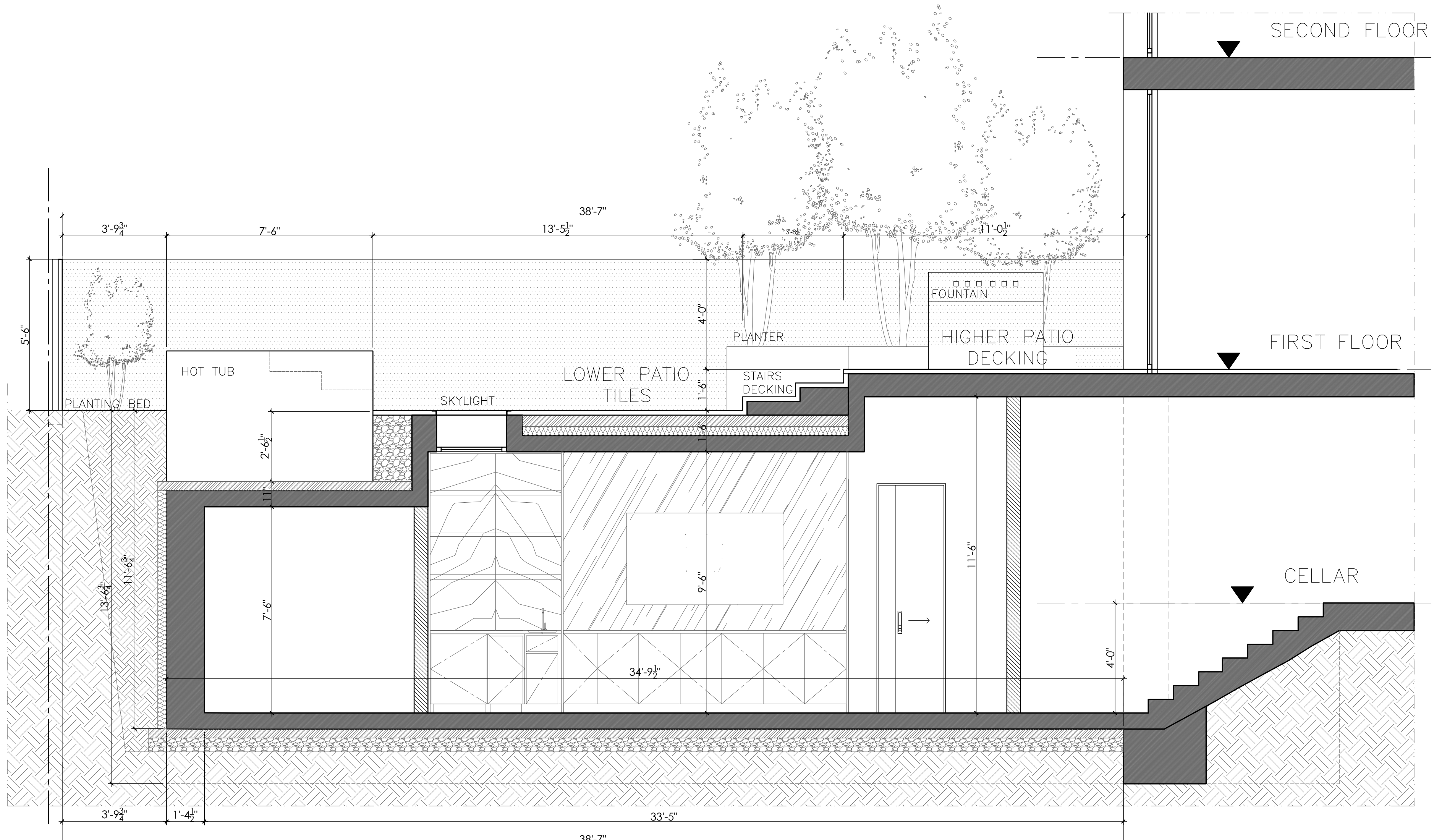

02 SECTION - REAR YARD LOOKING WEST, PROPOSED  
 3/8" = 1'-0"

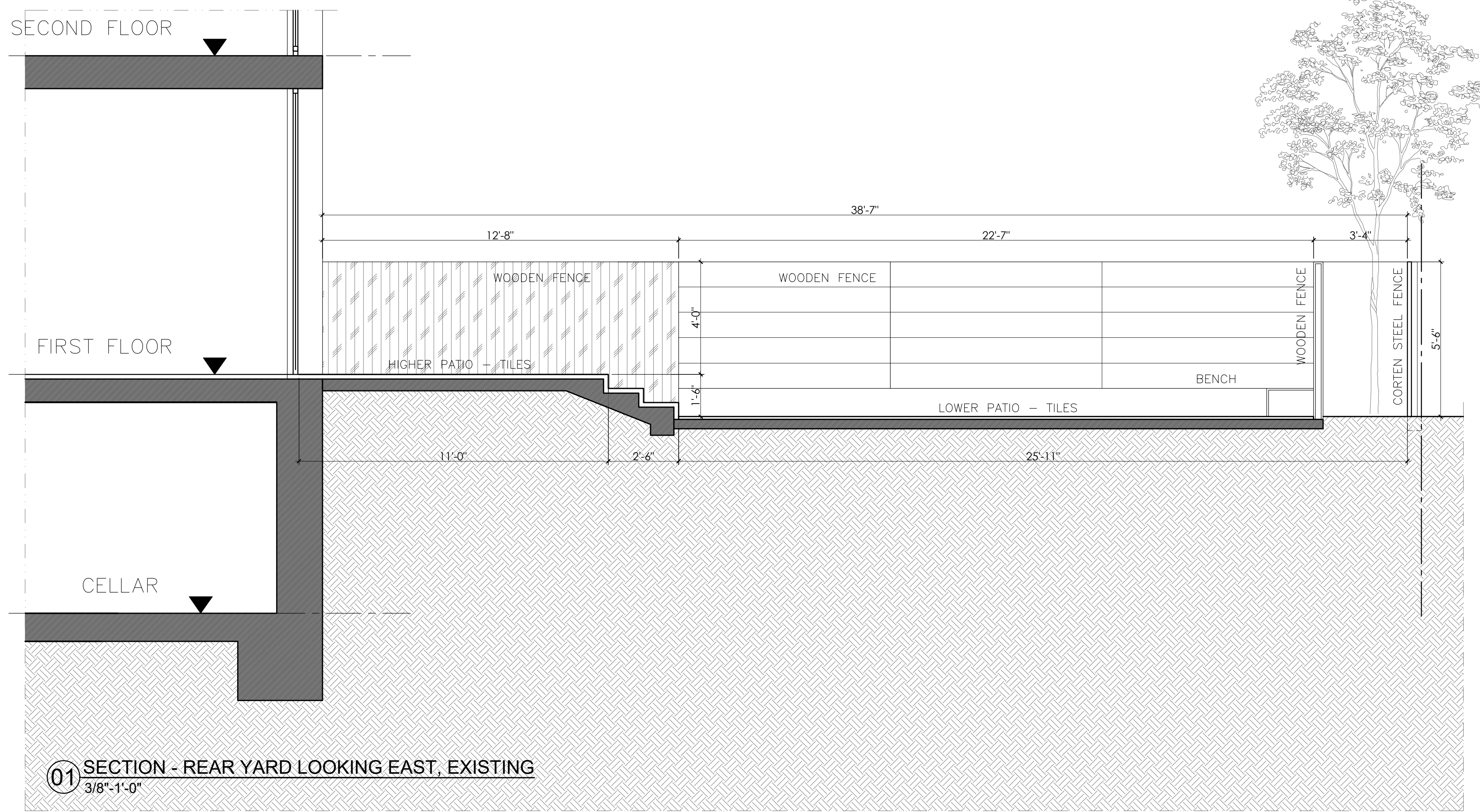

122 WAVERLY PLACE  
 REAR YARD EXCAVATION  
 DHD ARCHITECTURE PC  
 SARA KOSTIC AND LARISSA JIMENEZ  
 06/15/2023  
 LPC  
 SLIDE 08

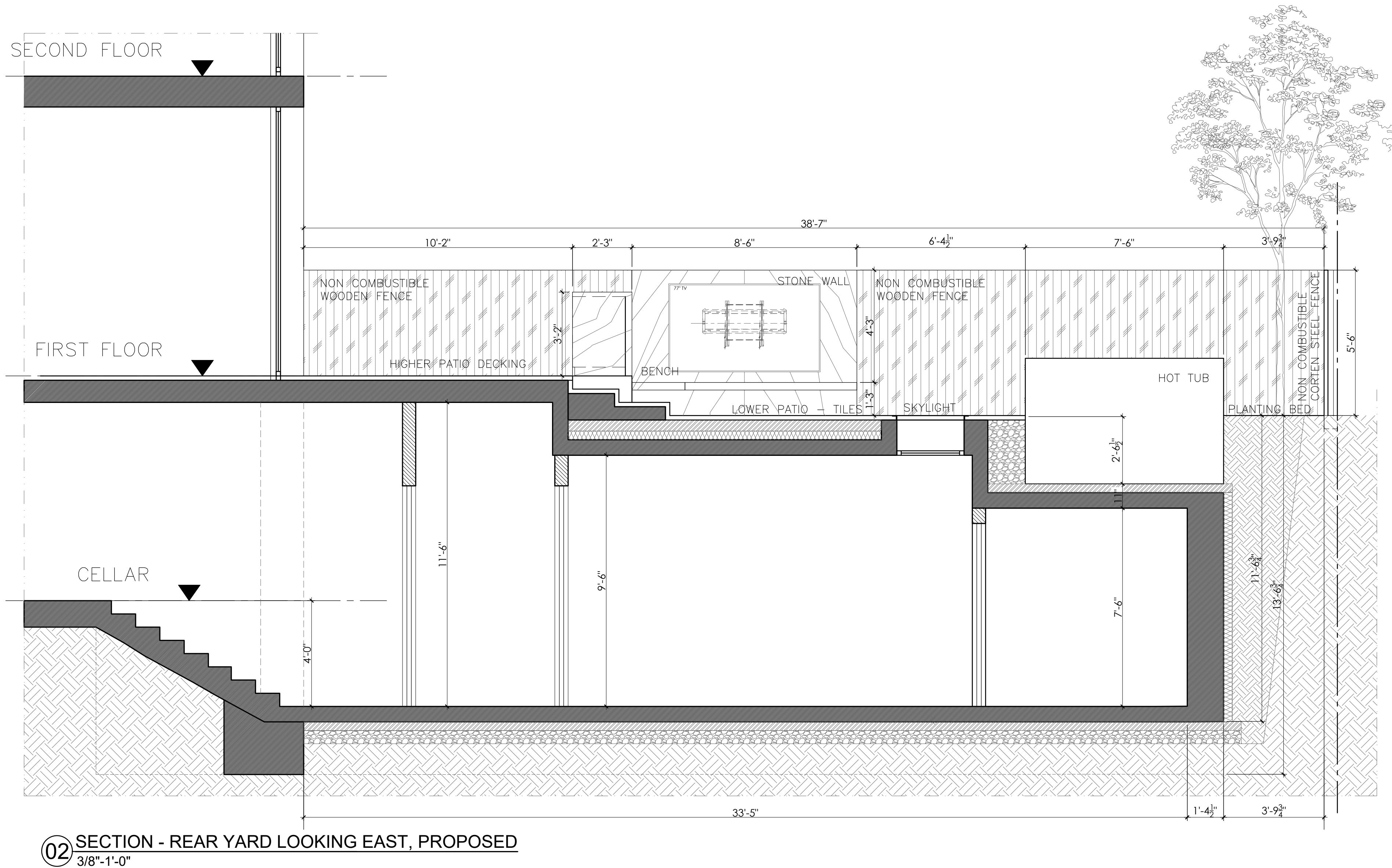



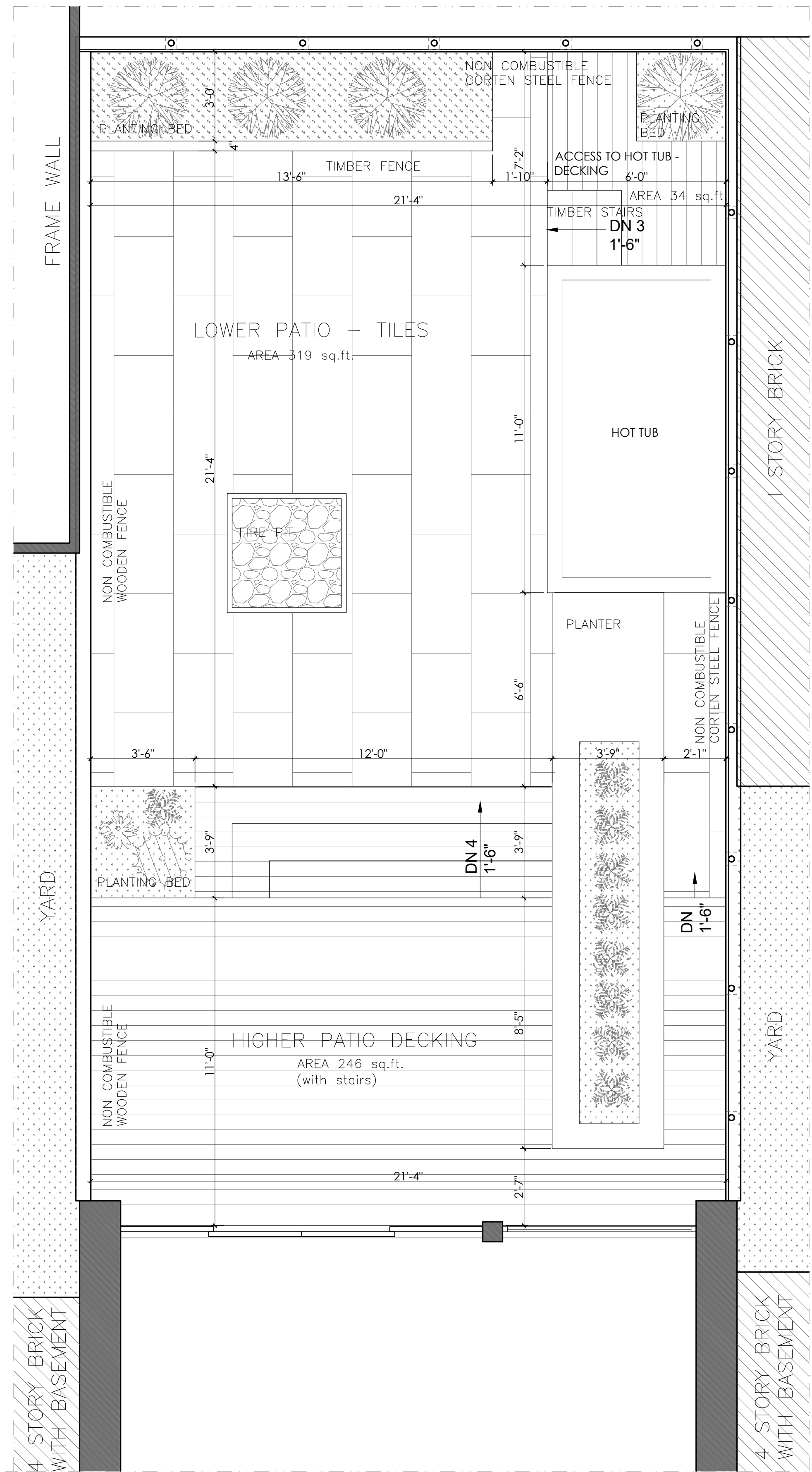
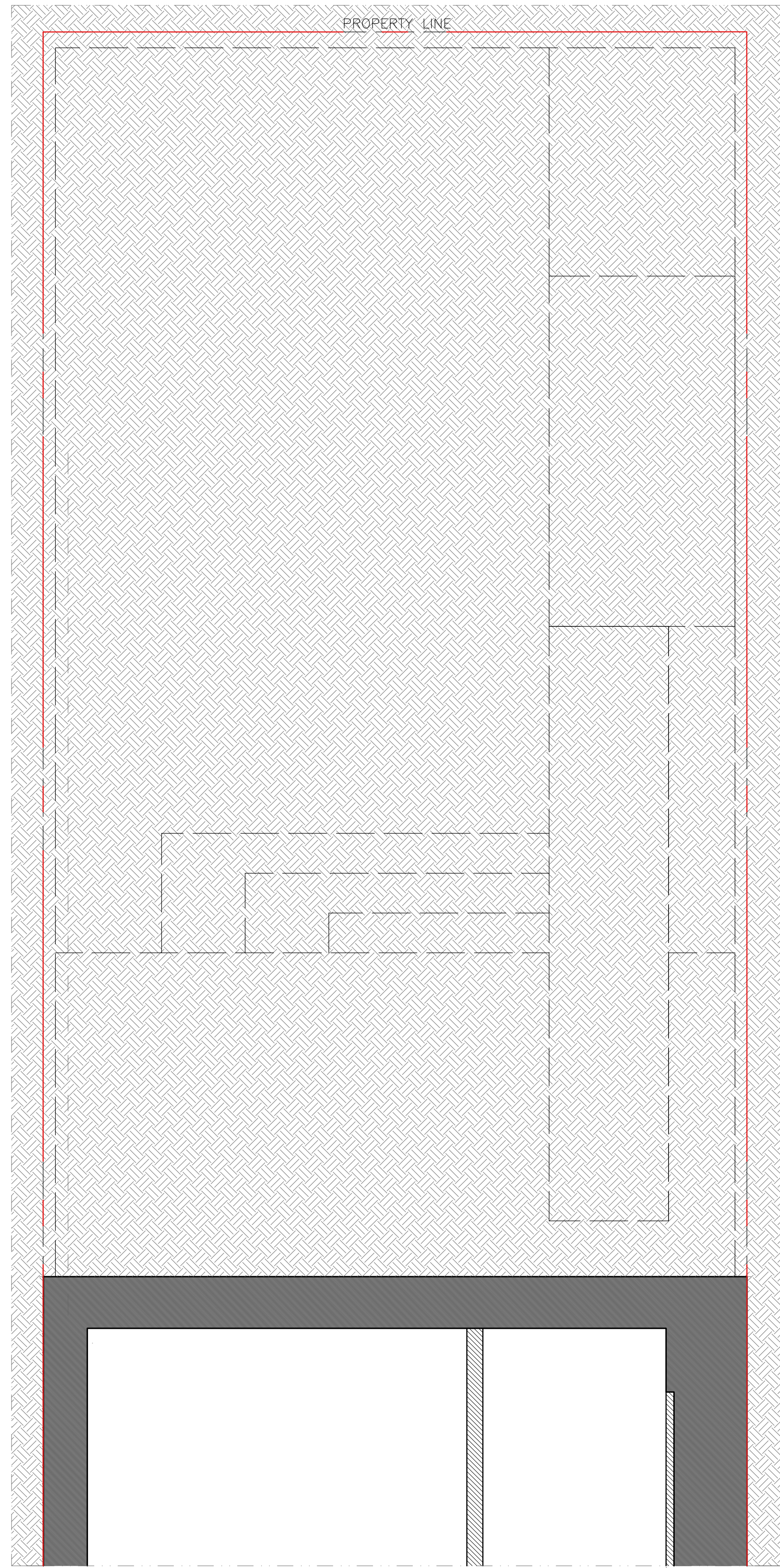

122 WAVERLY PLACE  
 REAR YARD EXCAVATION  
 DHD ARCHITECTURE PC  
 SARA KOSTIC AND LARISSA JIMENEZ  
 06/15/2023  
 LPC  
 SLIDE 09

02 AREA PLAN - REAR YARD CELLAR, APPROVED  
 3/8"-1'-0"

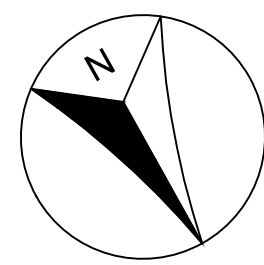

02 AREA PLAN - REAR YARD FIRST FLOOR, APPROVED  
 3/8"-1'-0" LPC docket number #22-07169 - Approved Staff level 2022

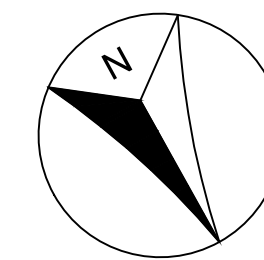

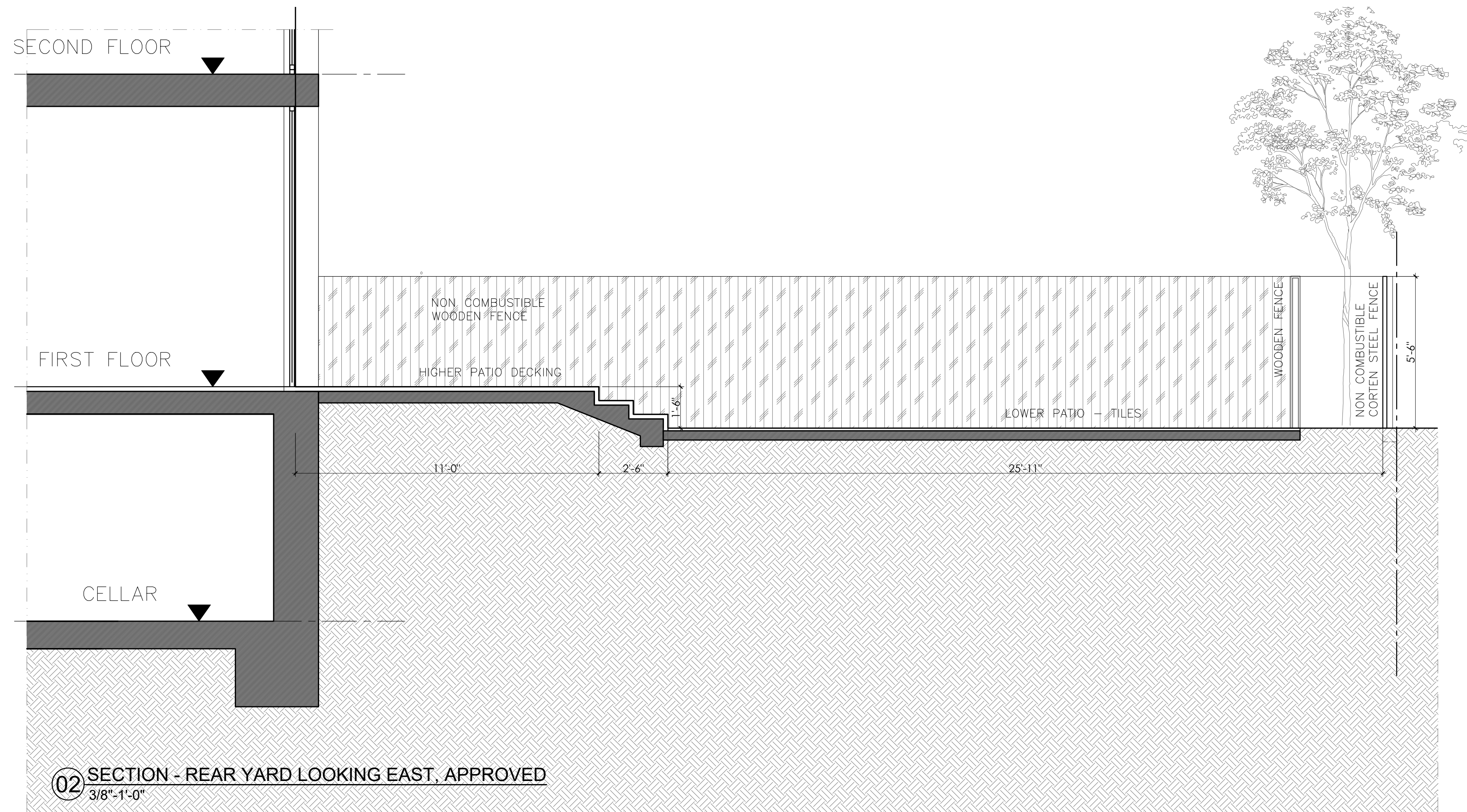
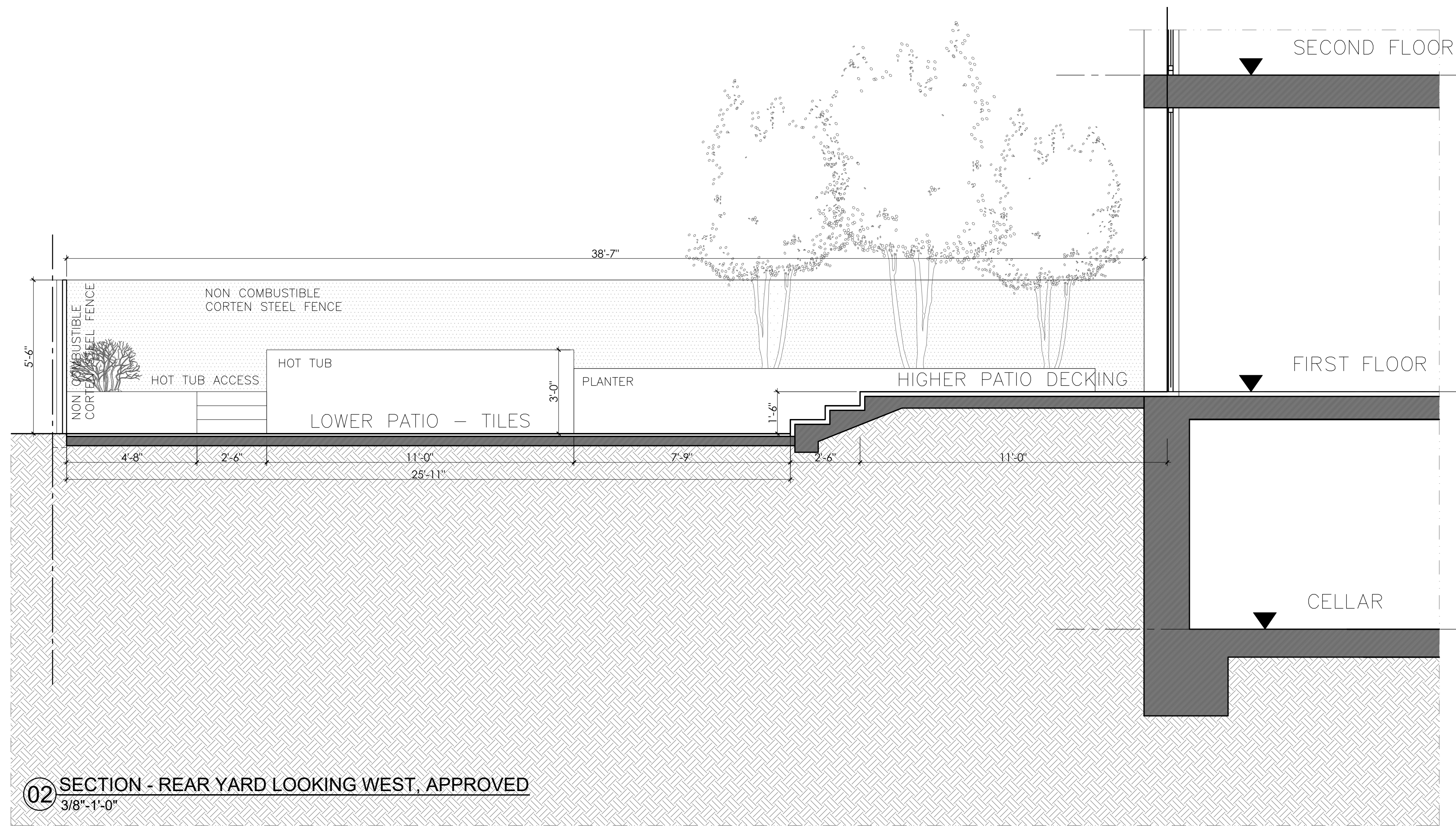

122 WAVERLY PLACE  
REAR YARD EXCAVATION  
DHD ARCHITECTURE PC  
SARA KOSTIC AND LARISSA JIMENEZ  
06/15/2023  
LPC  
SLIDE 10

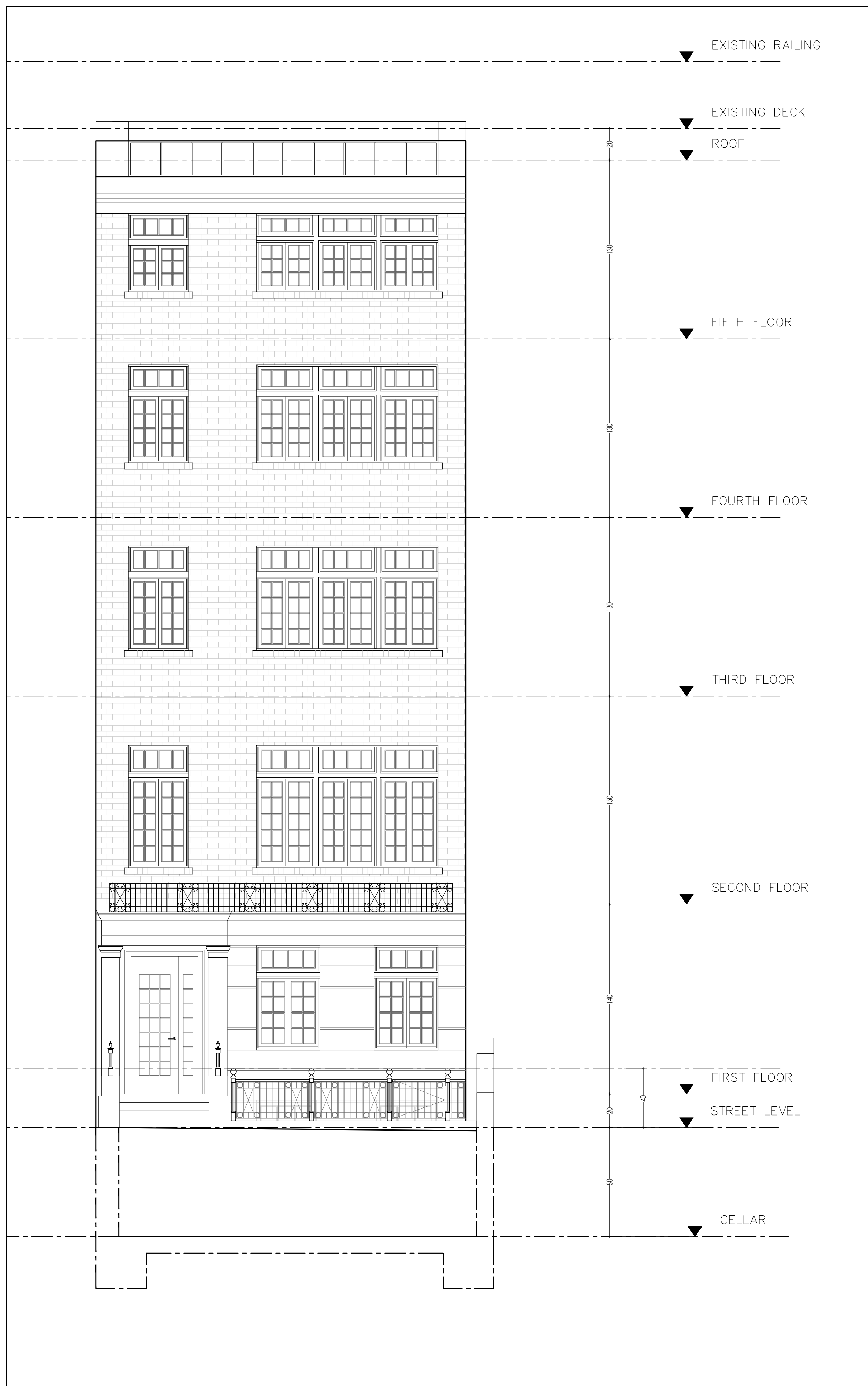

01 EXISTING ELAVATION - SOUTH - FRONT GATE  
SCALE 1/4"=1'-0"

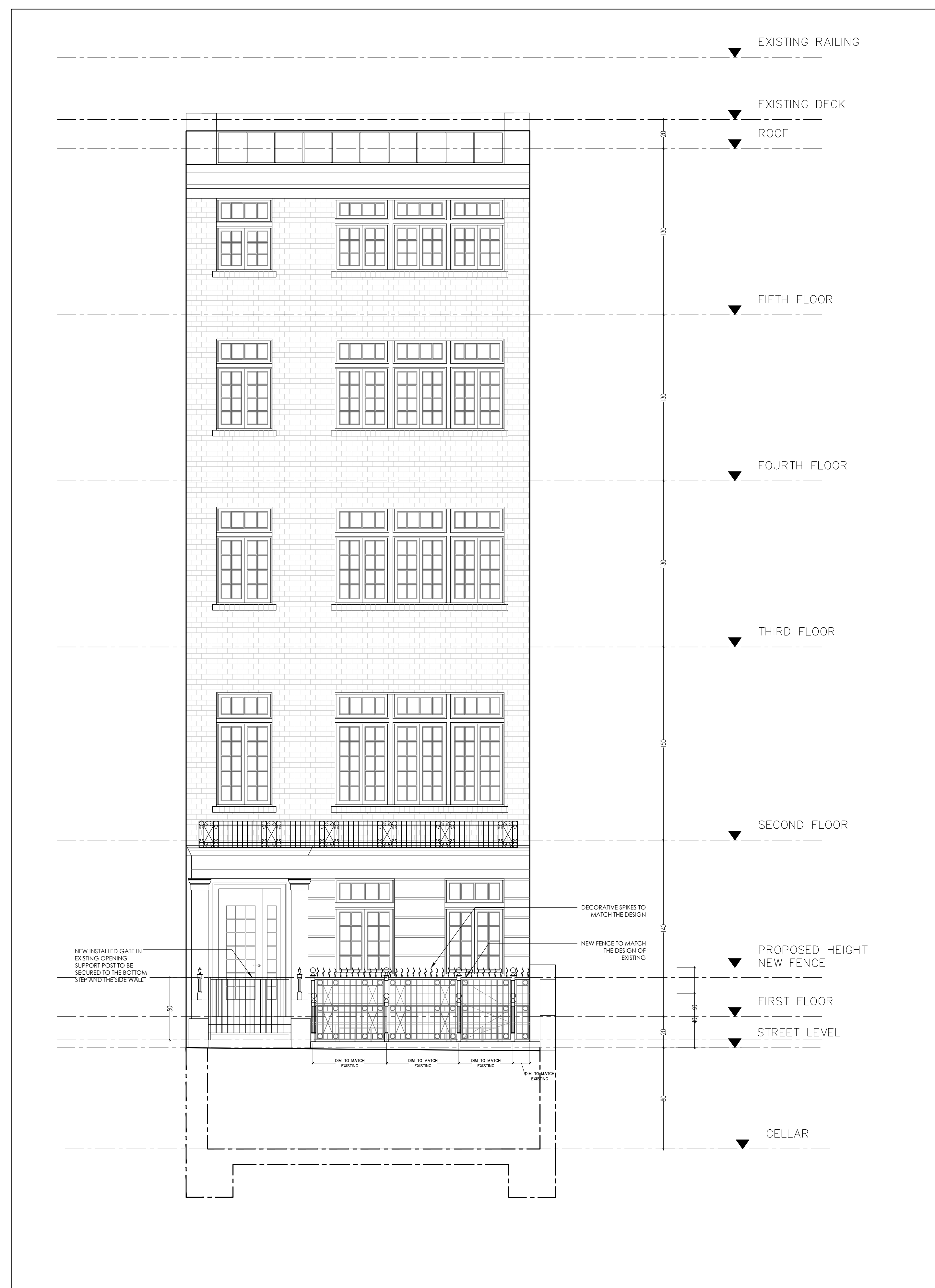

02 PROPOSED ELAVATION - SOUTH - FRONT GATE  
SCALE 1/4"=1'-0"

122 WAVERLY PLACE  
REAR YARD EXCAVATION  
DHD ARCHITECTURE PC  
SARA KOSTIC AND LARISSA JIMENEZ  
06/15/2023  
LPC  
SLIDE 11



01 PROPOSED ELEVATION 1 - SOUTH  
 SCALE: 3/4"=1'-0"

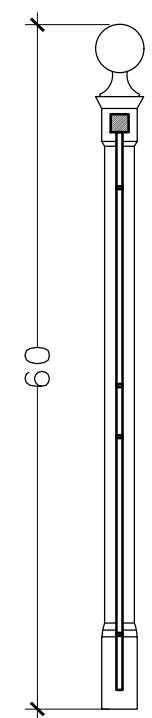

02 PROPOSED FENCE SECTION  
 SCALE: 3/4"=1'-0"



03 1940'S TAX PHOTO  
 SCALE: 3/4"=1'-0"



01 119 WAVERLY PLACE  
FRONT GATE AND FENCE



02 138 WAVERLY PLACE  
FRONT GATE AND FENCE

122 WAVERLY PLACE  
REAR YARD EXCAVATION  
DHD ARCHITECTURE PC  
SARA KOSTIC AND LARISSA JIMENEZ  
06/15/2023  
LPC  
SLIDE 13