

**14 GAY STREET
PUBLIC HEARING PRESENTATION**

11.05.2021

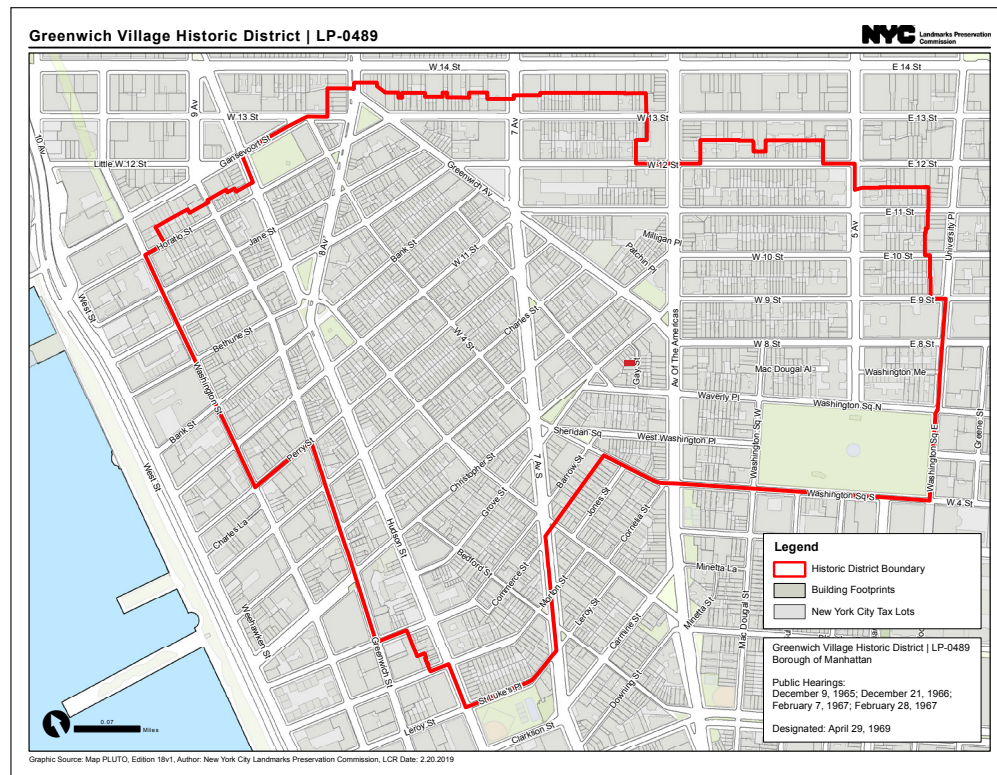

14 GAY STREET



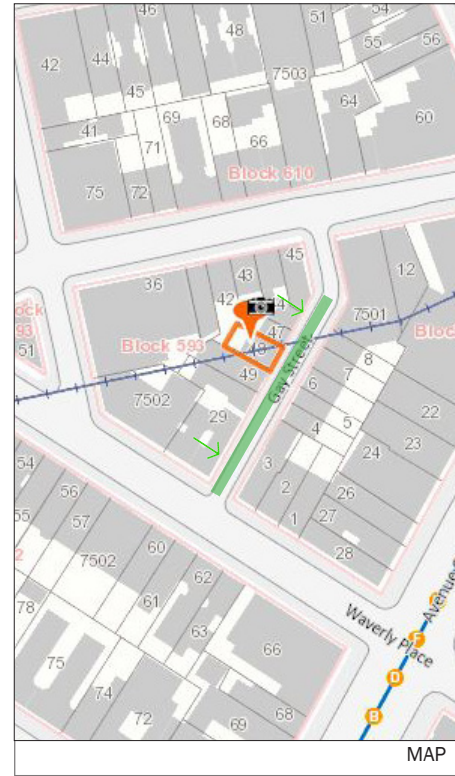

EAST ELEVATION

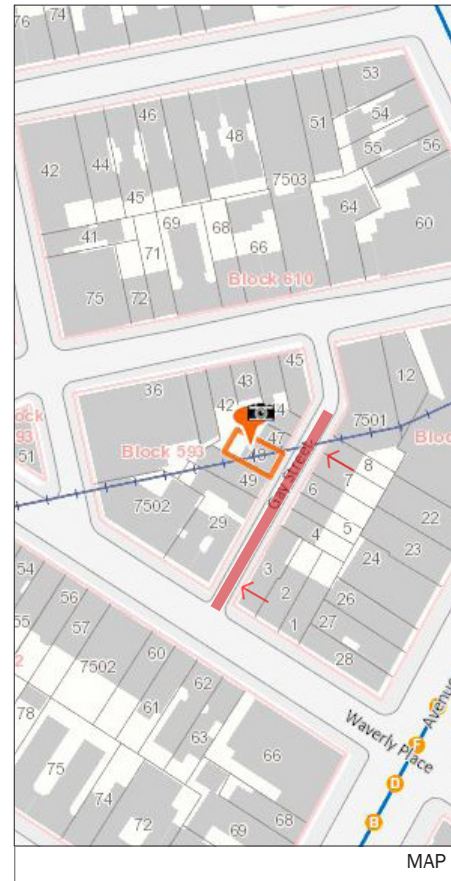

WEST ELEVATION



PROPOSED ENTRANCE 14 GAY STREET - WEST ELEVATION





VIEW 1



VIEW 2



VIEW 3

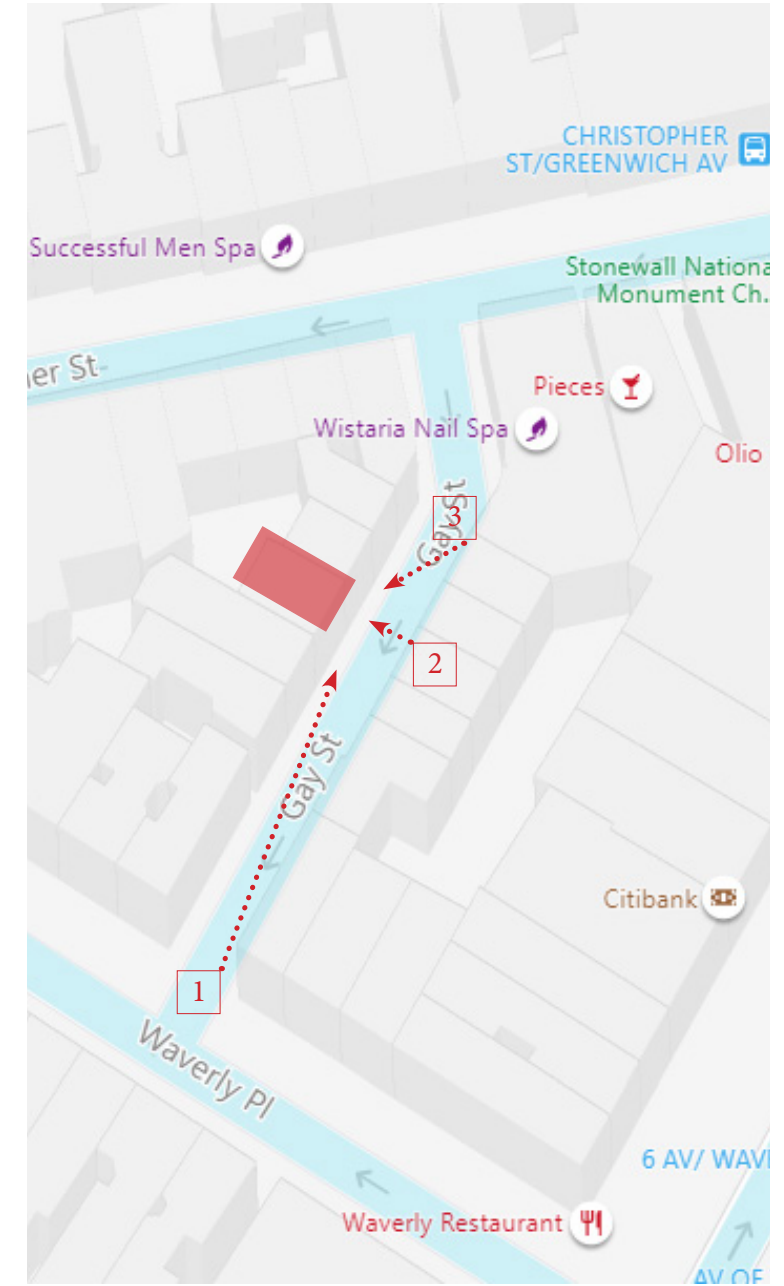

KEY PLAN



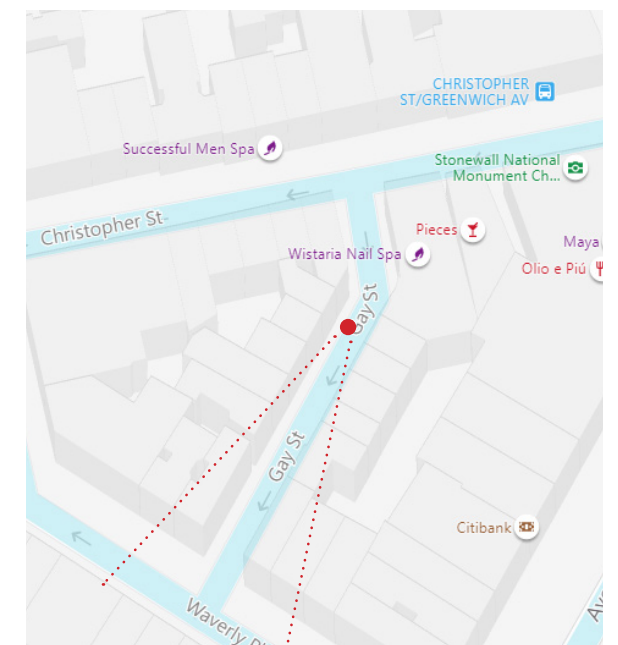



9 GAY STREET ENTRANCE GATE



13 GAY STREET ENTRANCE GATE



15 GAY STREET ENTRANCE GATE



12 GAY STREET ENTRANCE GATE



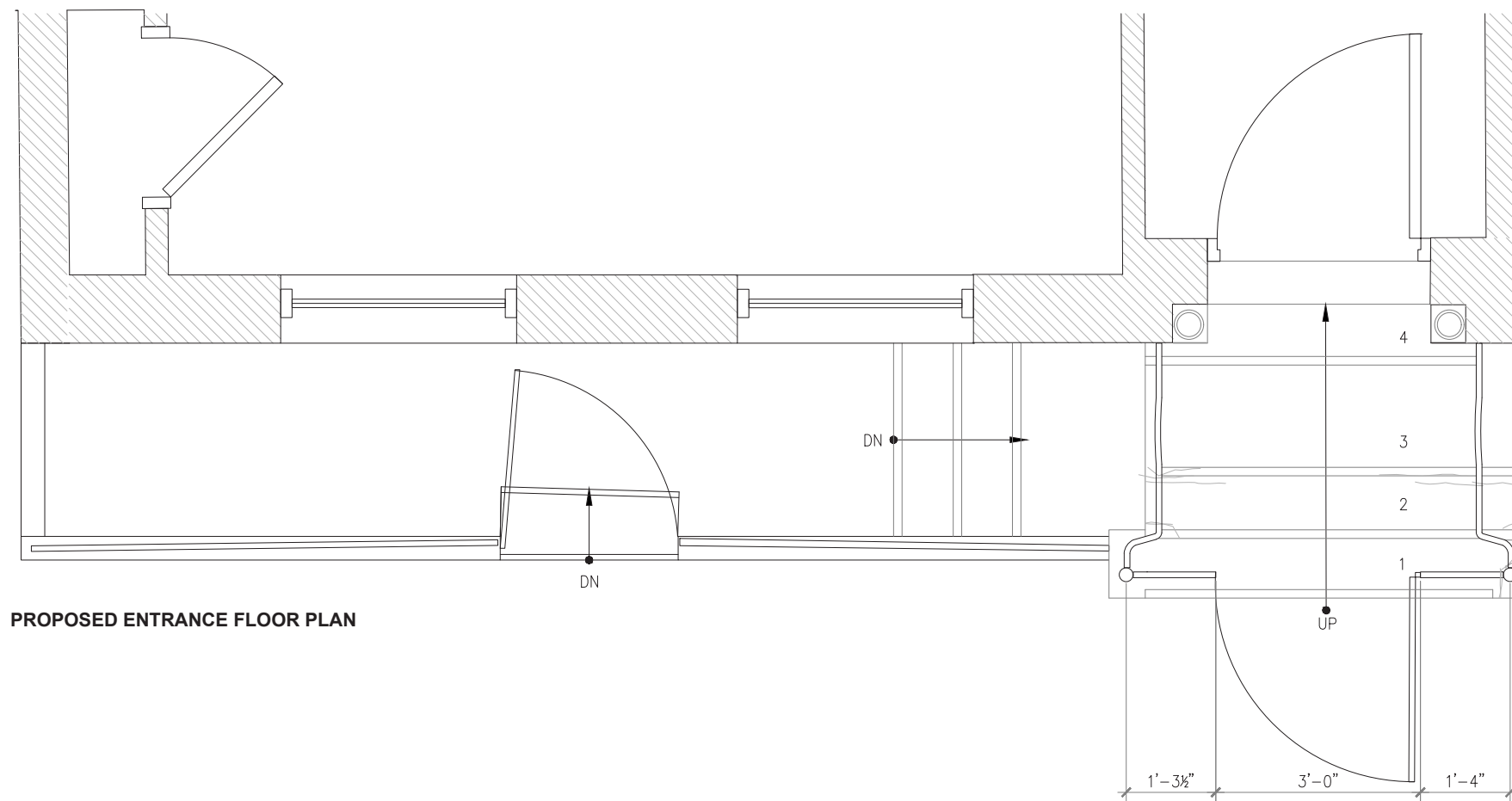
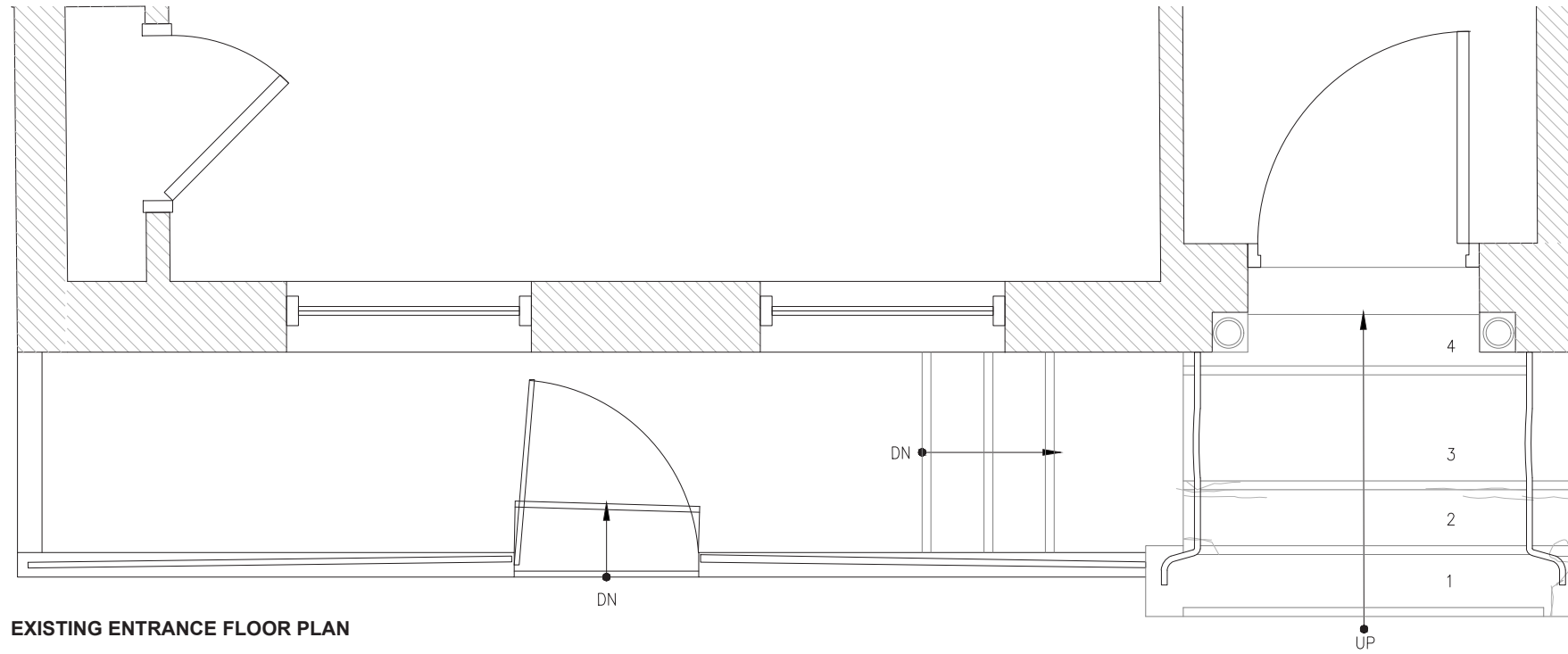



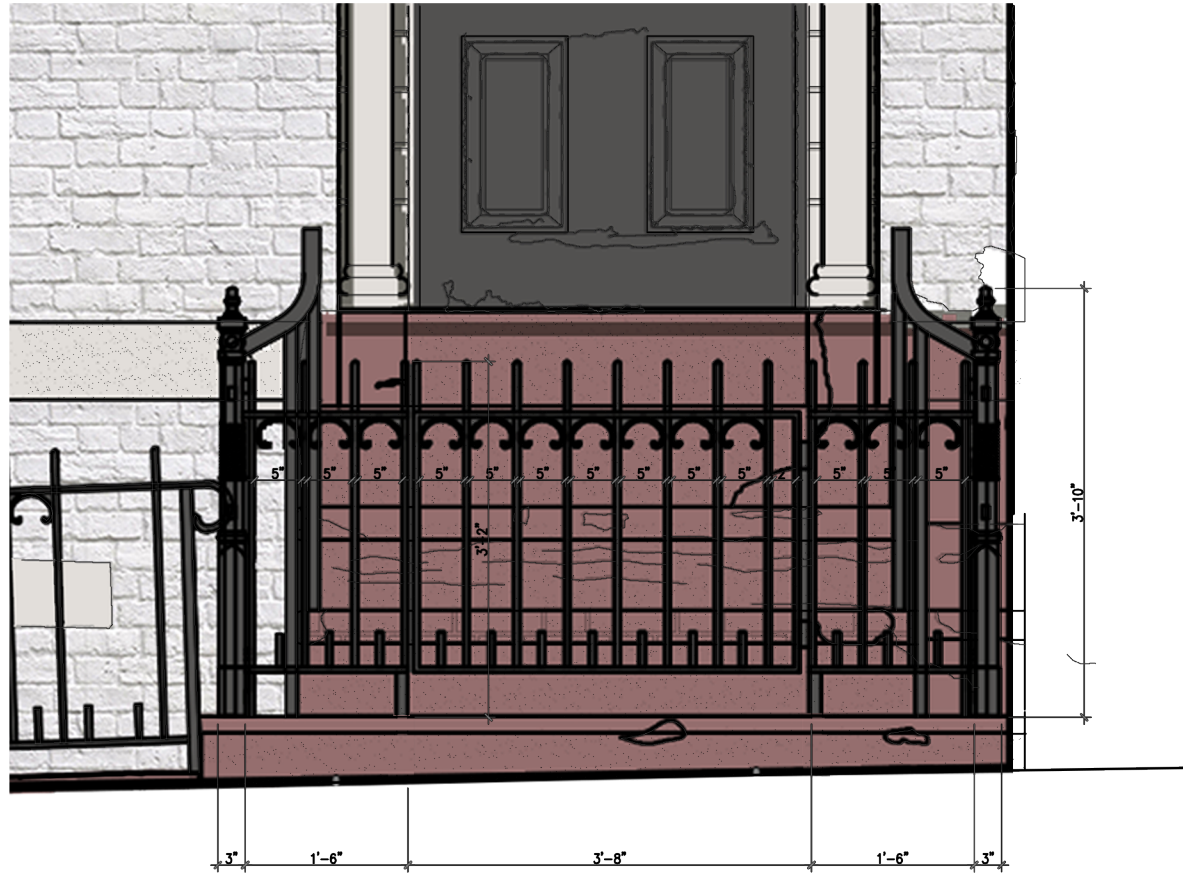

PROPOSED ENTRANCE ELEVATION WITH
OPEN GATE

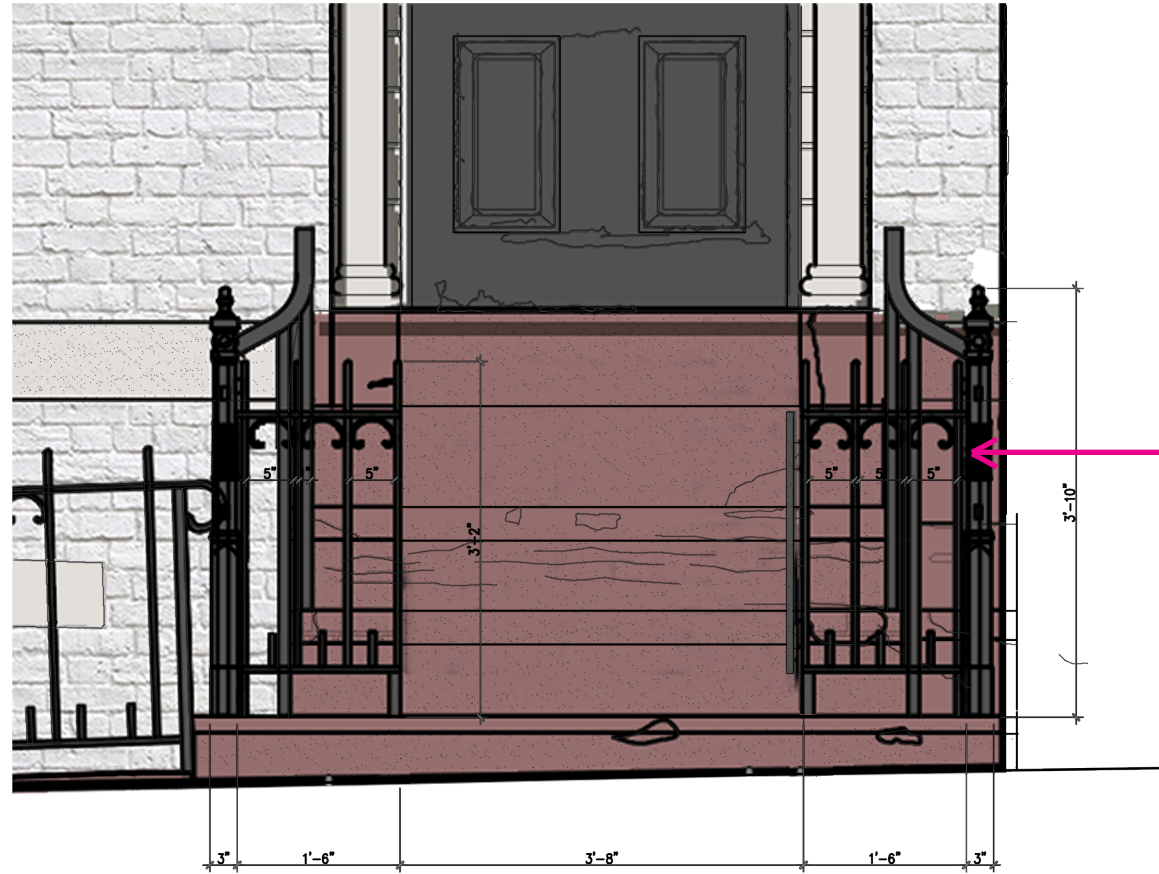

PROPOSED ENTRANCE ELVATION WITH
CLOSED GATE

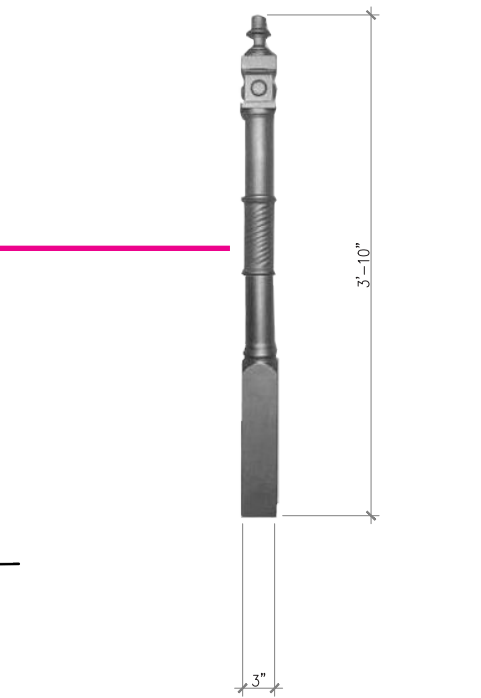

PROPOSED ENTRANCE ELVATION WITH
CLOSED GATE

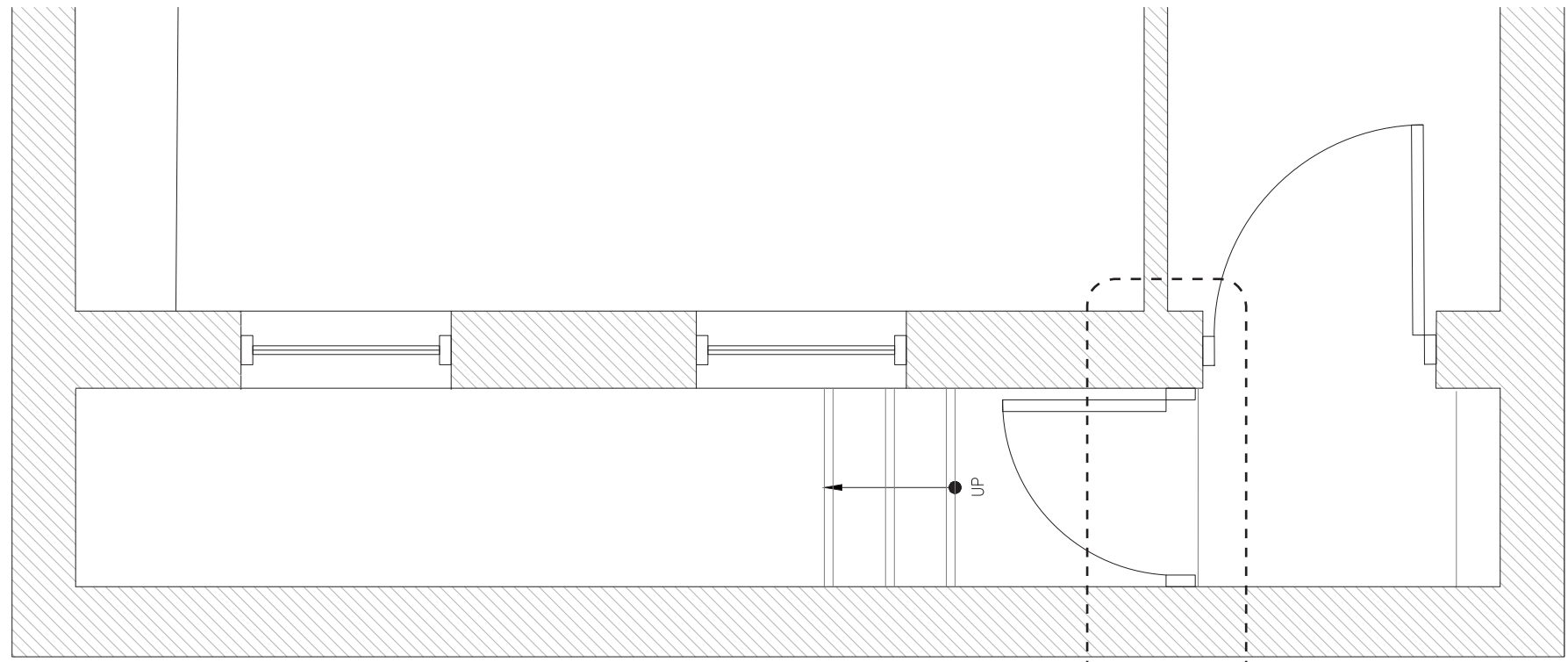

EXISTING CELLAR FLOOR PLAN

AREA OF WORK:
CHANGE ROTATION OF A HINGE

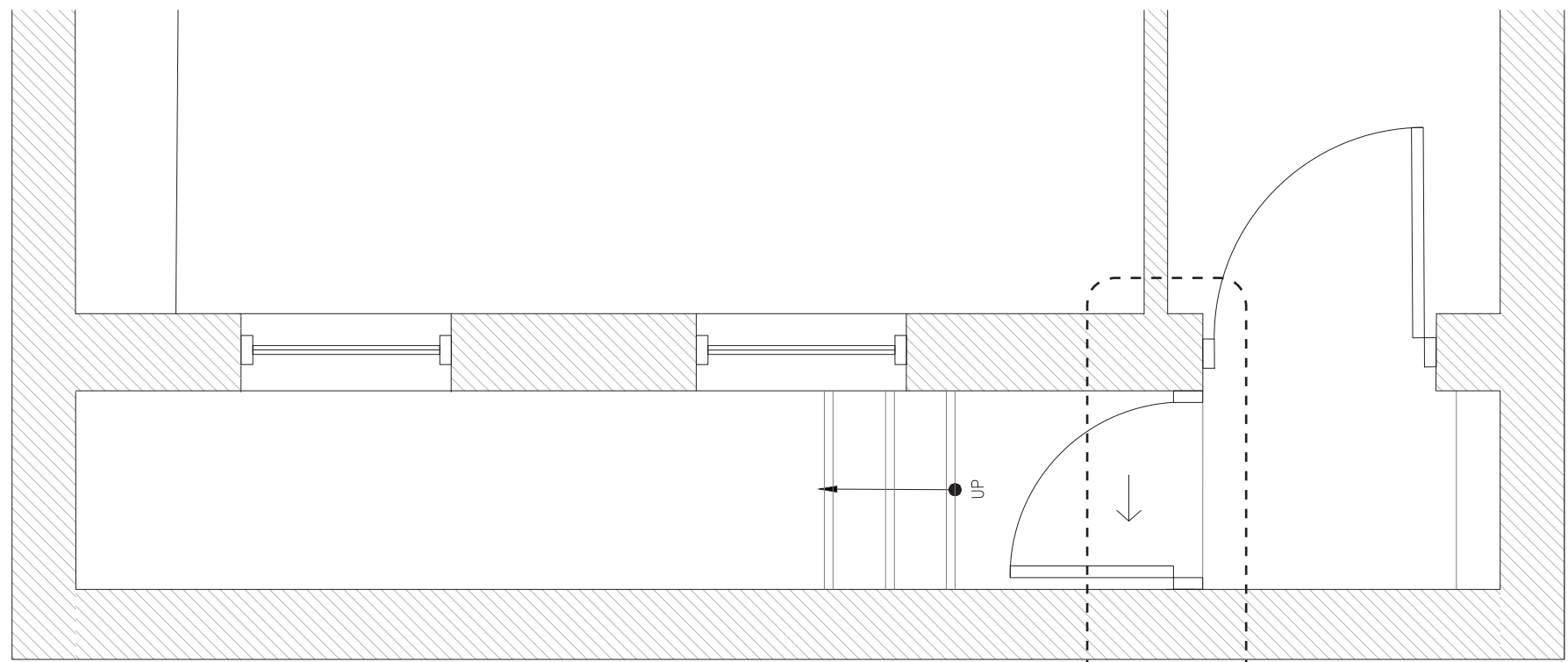

PROPOSED CELLAR FLOOR PLAN

AREA OF WORK:
CHANGE ROTATION OF A HINGE



16 GAY STREET EXISTING CELLAR GATE



12 GAY STREET EXISTING CELLAR GATE



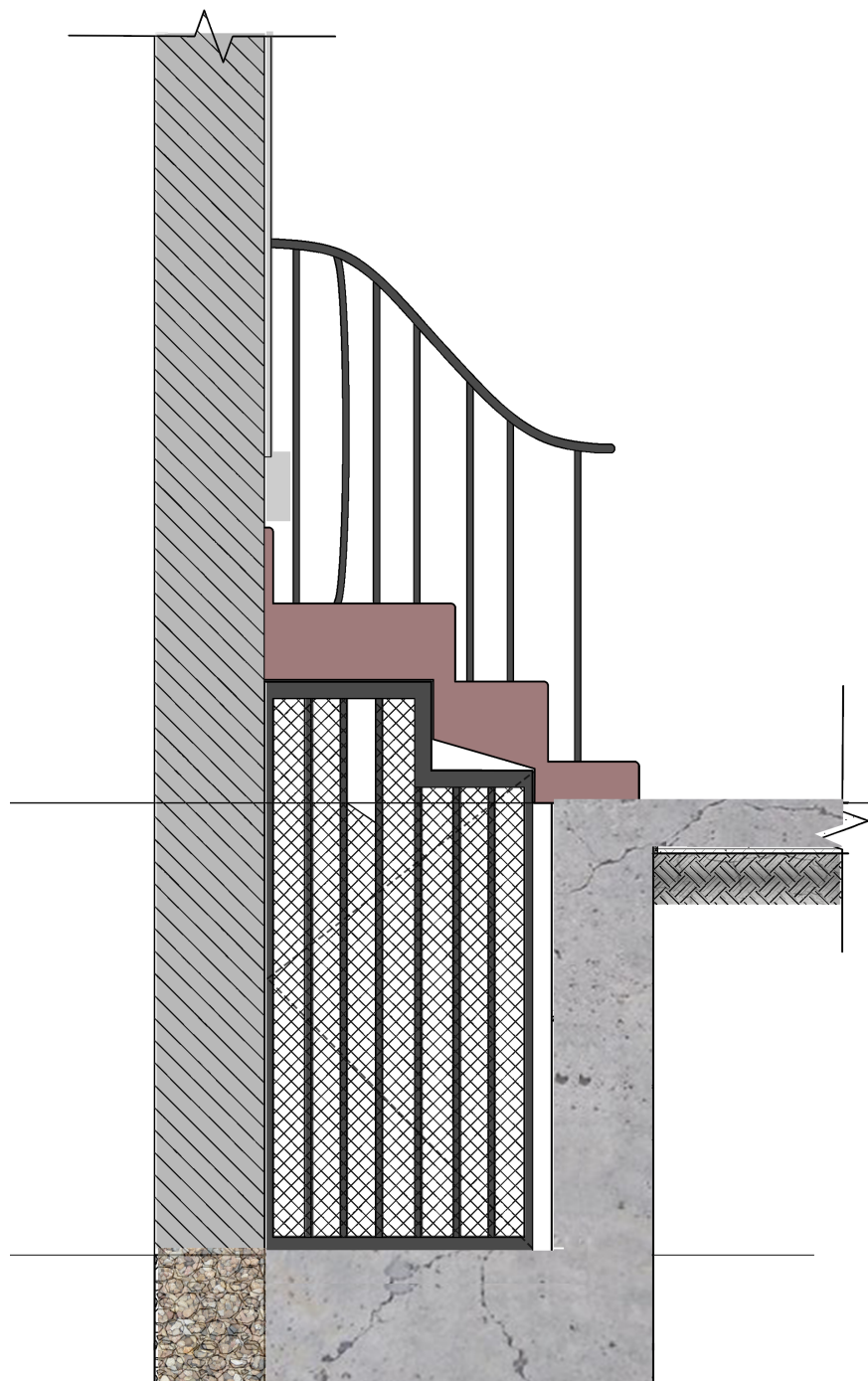

EXISTING CELLAR ENTRANCE SECTION

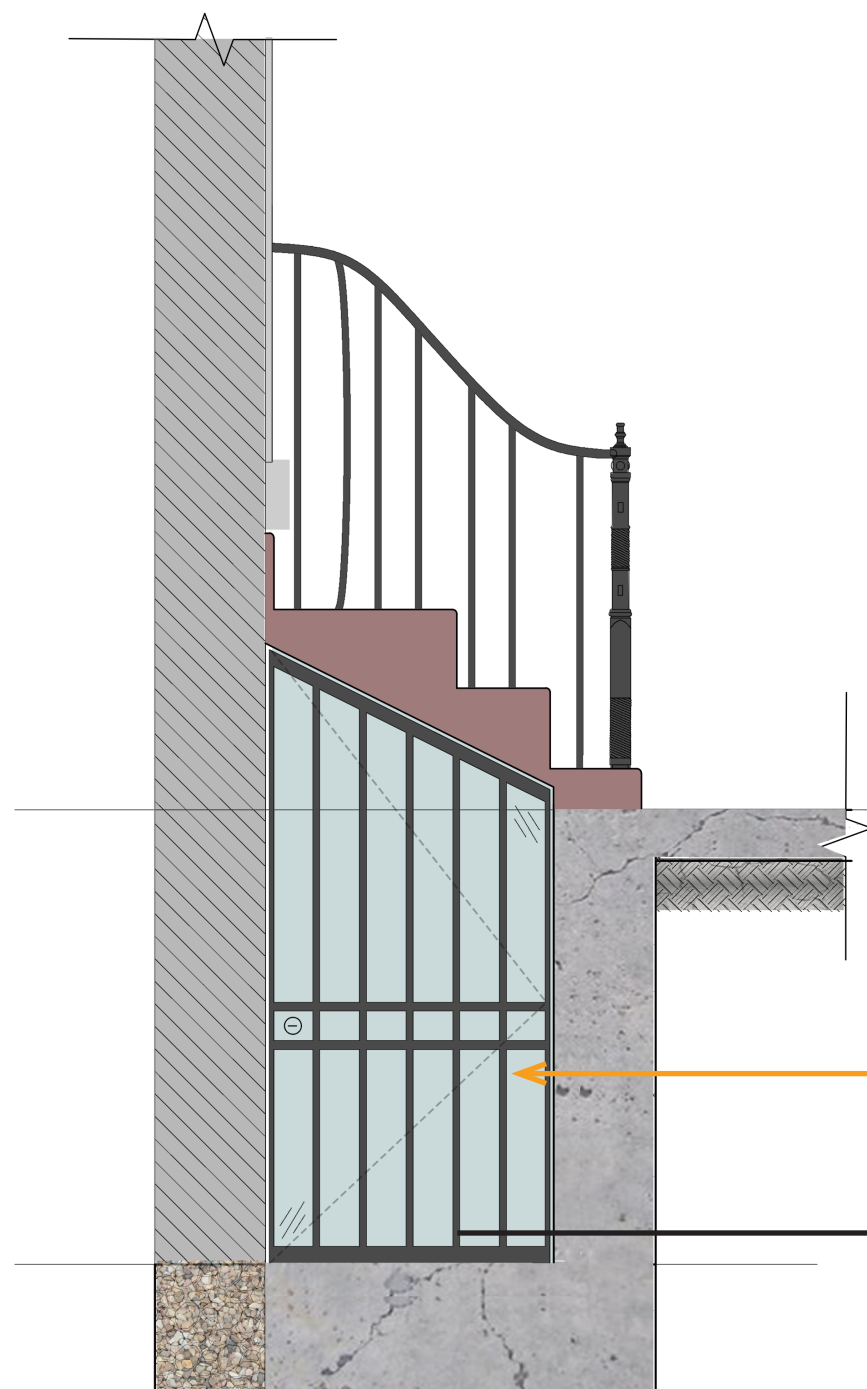

CELLAR ENTRANCE SECTION

Gate color
 Color
 R: 47
 G: 44
 B: 48



GLAZED GATE FOR WEATHER PROTECTION