

FORMAT ARCHITECTURE OFFICE

406 West 13th Street

Manhattan Community Board 2 - LPC Presentation

05 March 2021

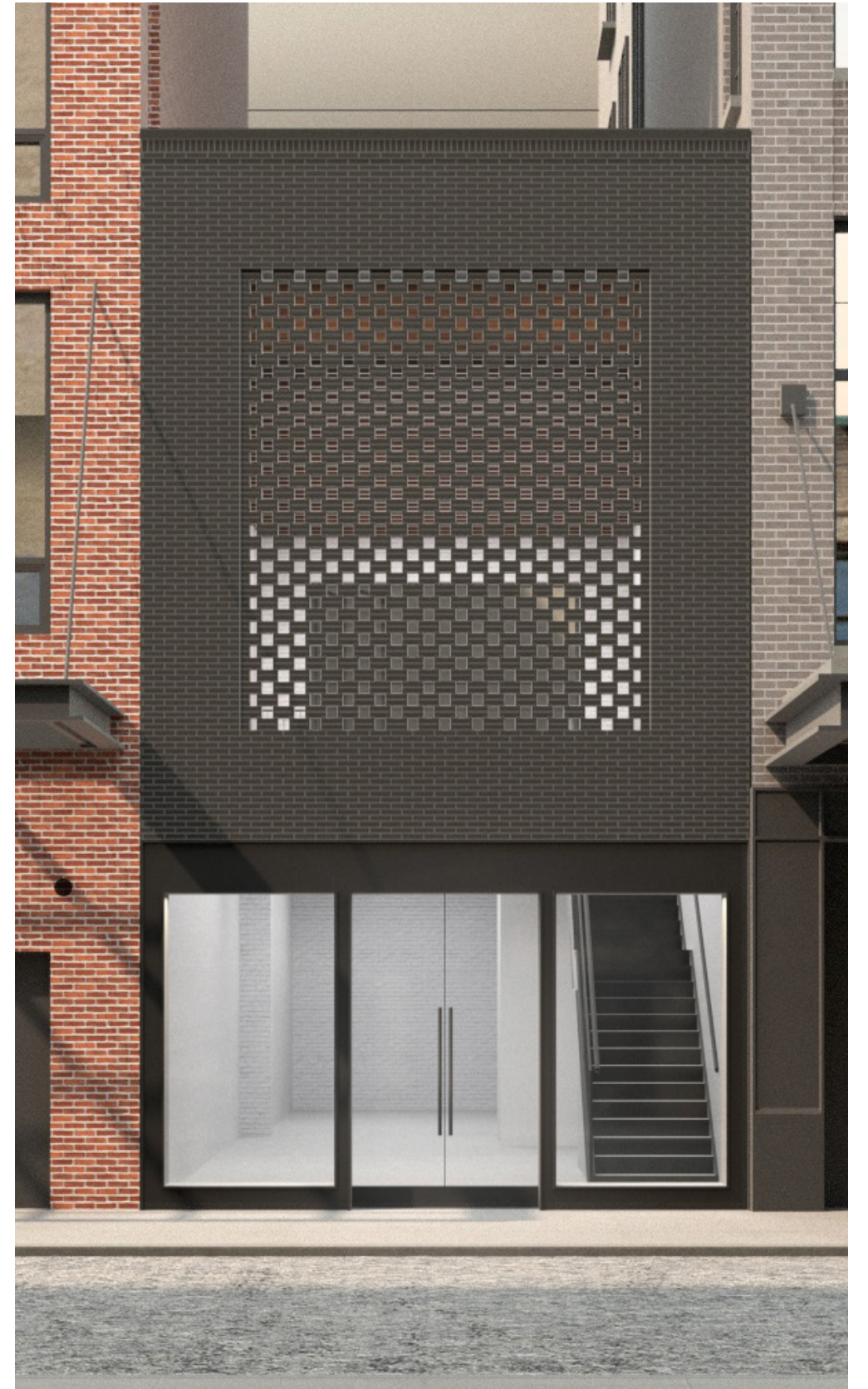

Context & Existing Conditions

Gansevoort Market Historic District

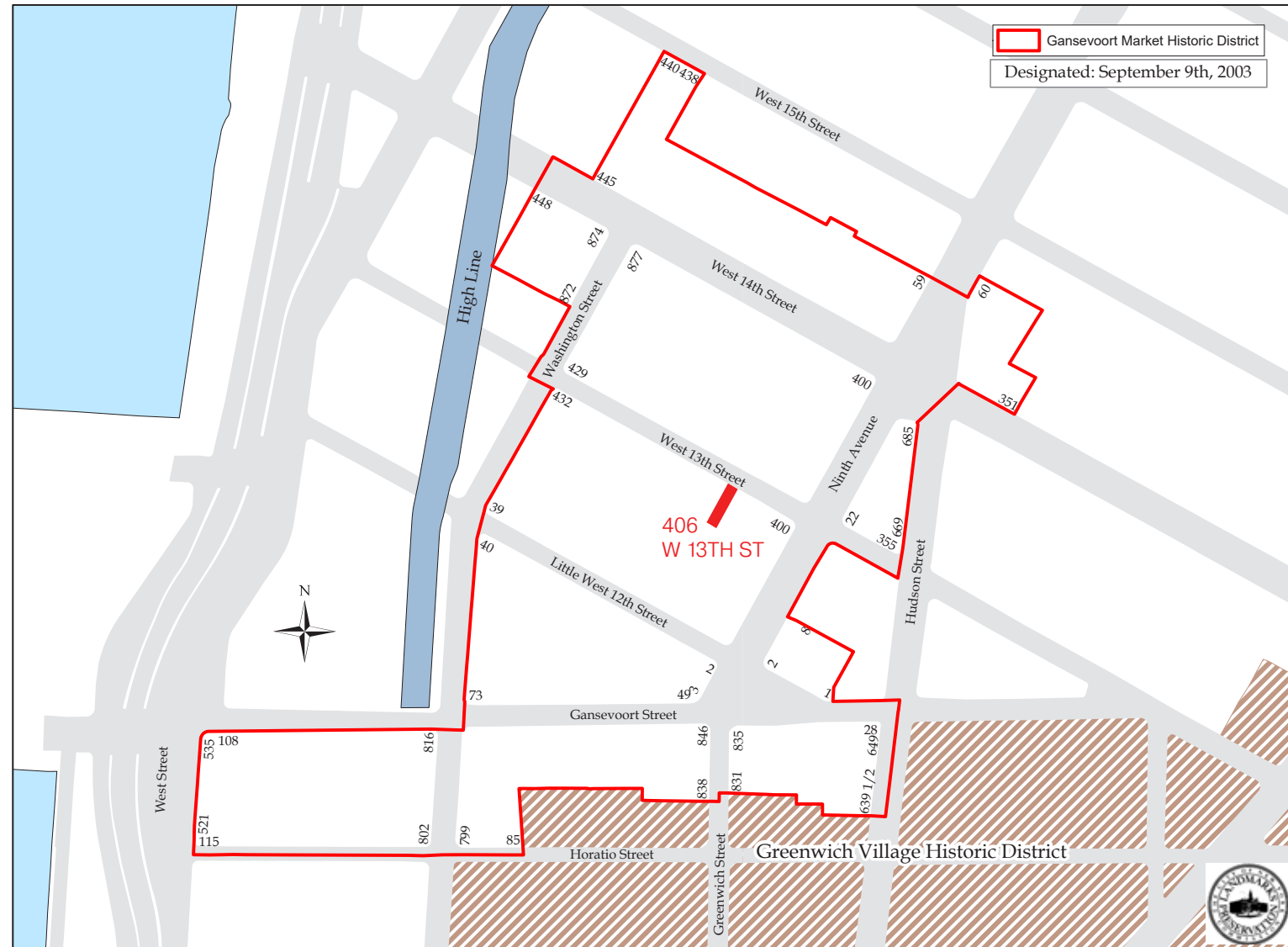

District Map



2017 NYC Tax Map

Site Location: 406 West 13th Street

406 West 13th Street



Tax Photo (1940) - 1846 Greek Revival Rowhouse



Tax Photo (1980) - 1955 Alteration (No Style)



Current Condition (2021) - No Style

Historic Conditions

406 West 13th Street

BLOCK 645

402-404 and 406 WEST 13TH STREET
Tax Map Block 645, Lots 39 and 38

Date: 1950 (Alt. 1165-1950); 1955 (Alt. 683-1955)
Architect: Abraham L. Seiden
Owner: 402/404 West 13th Street Corps.; 406 West 13th Street Corp.

Type: Market buildings (2)
Style: none
Stories: 2
Facade Materials: brick, metal canopy

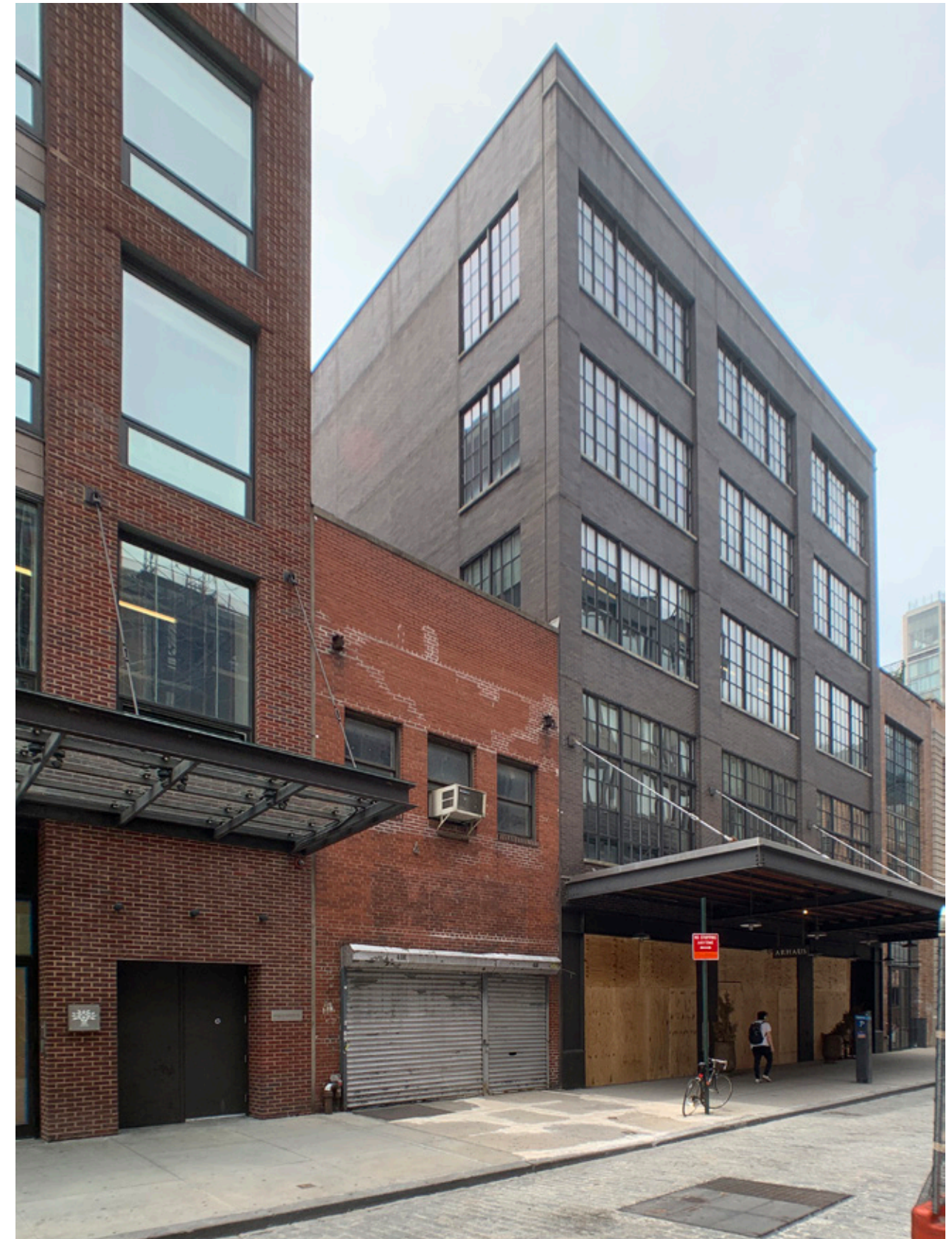

Designation Report & Existing Conditions

406 West 13th Street



View from 9th Ave and W 13th St Corner

406 West 13th Street



21-27 Ninth Avenue



29 Ninth Avenue



405-409 West 13th Street



412 West 13th Street



416 West 13th Street



417 West 13th Street

West 13th Street Context

406 West 13th Street

**Proposed
Design**

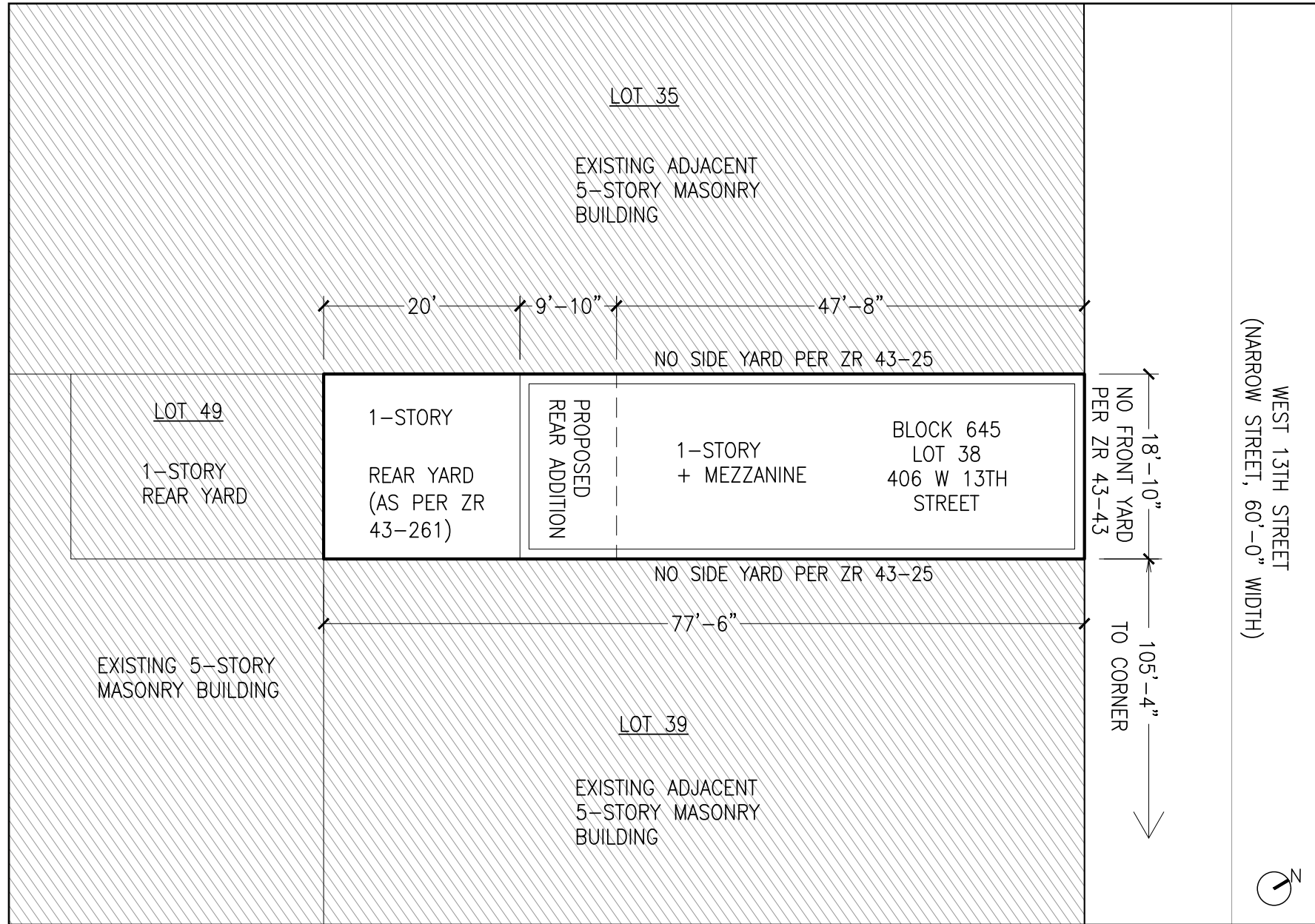

Plot Plan

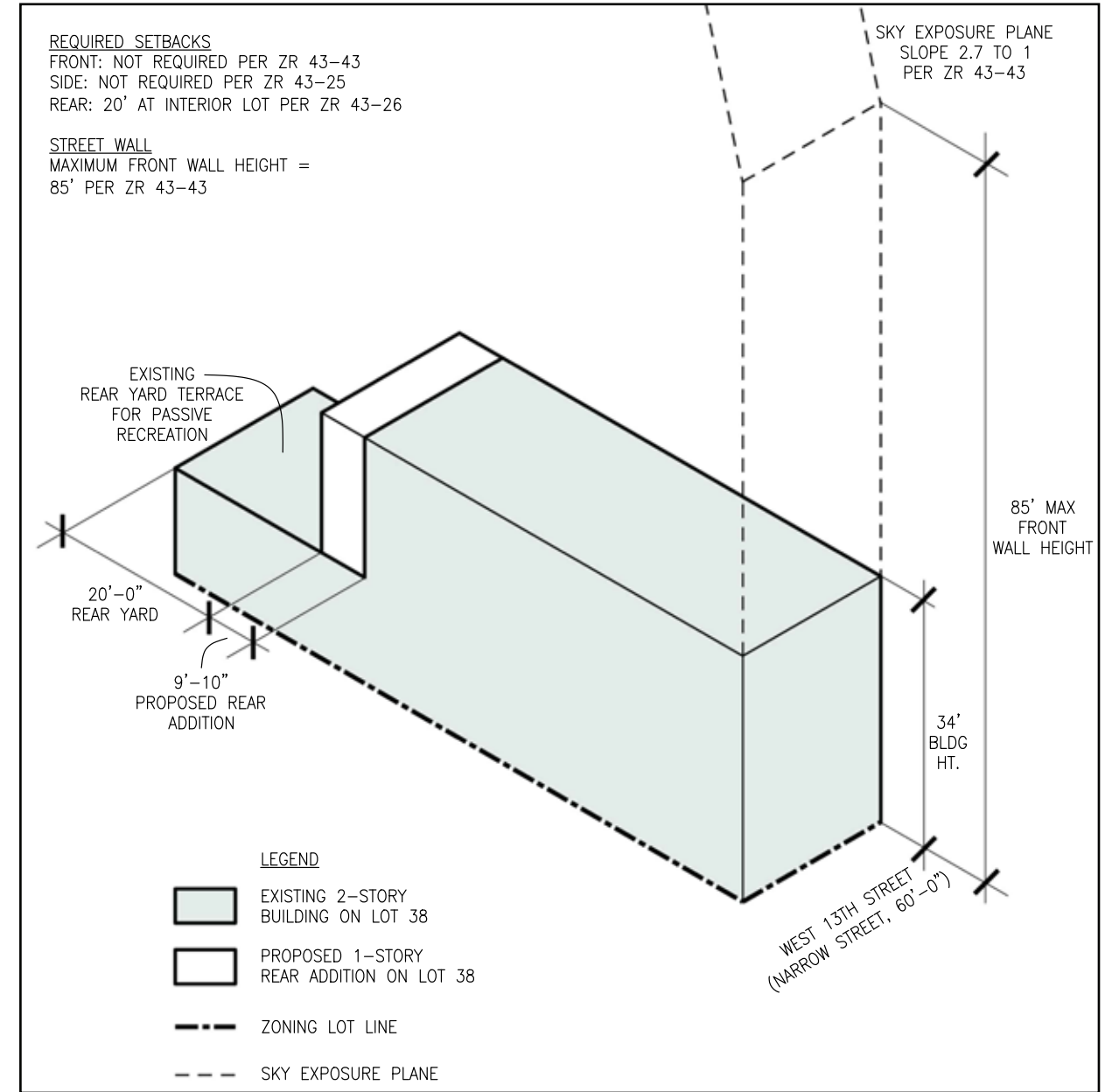

Zoning Envelope Analysis

Site Location: 406 West 13th Street

406 West 13th Street



Neighborhood Context - West 13th Street South Elevation

406 West 13th Street

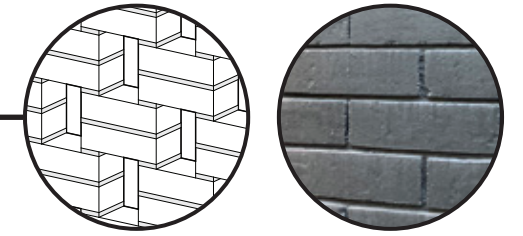

Stacked modular brick screen, painted dark gray (Duranar Charcoal)

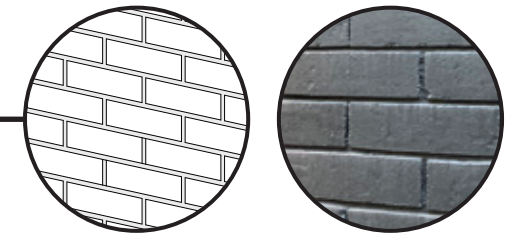

Running bond, modular brick, painted dark gray (Duranar Charcoal)

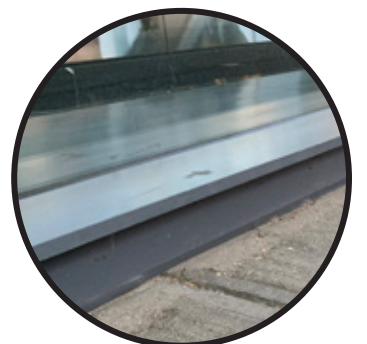

Steel and glass storefront, painted dark gray (Duranar Graphite)

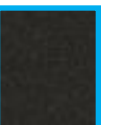

Proposed Design

Front Facade - 406 W 13th Street



1 872-874 Washington Street (Queen Anne)



2 859-877 Washington Street (Queen Anne)



3 410 West 14th Street (Arts and Crafts)

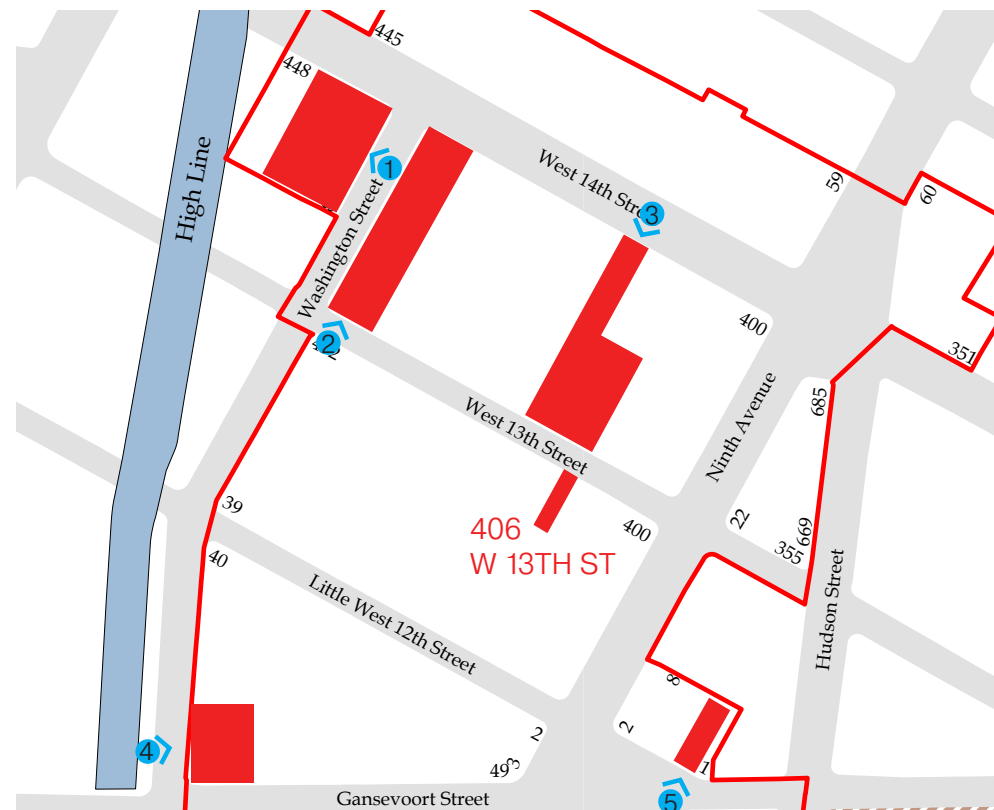

District Map



4 817-821 Washington Street (Queen Anne)



5 1 Little West 12th Street (Neo Grec)

Precedents - Brick Spandrel & Frame Details

406 West 13th Street

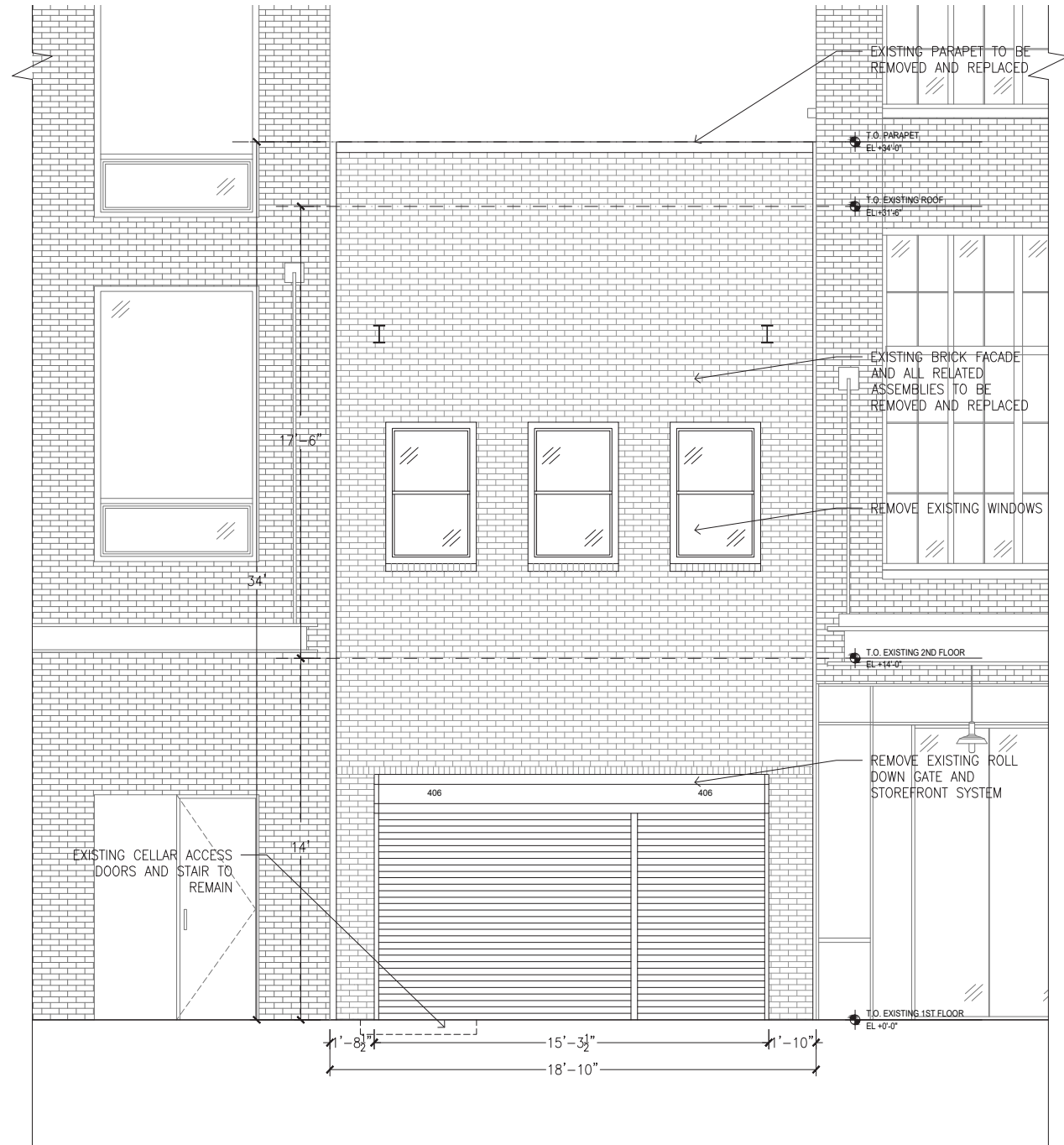

01 BUILDING FRONT ELEVATION - EXISTING
1/4"=1'-0"

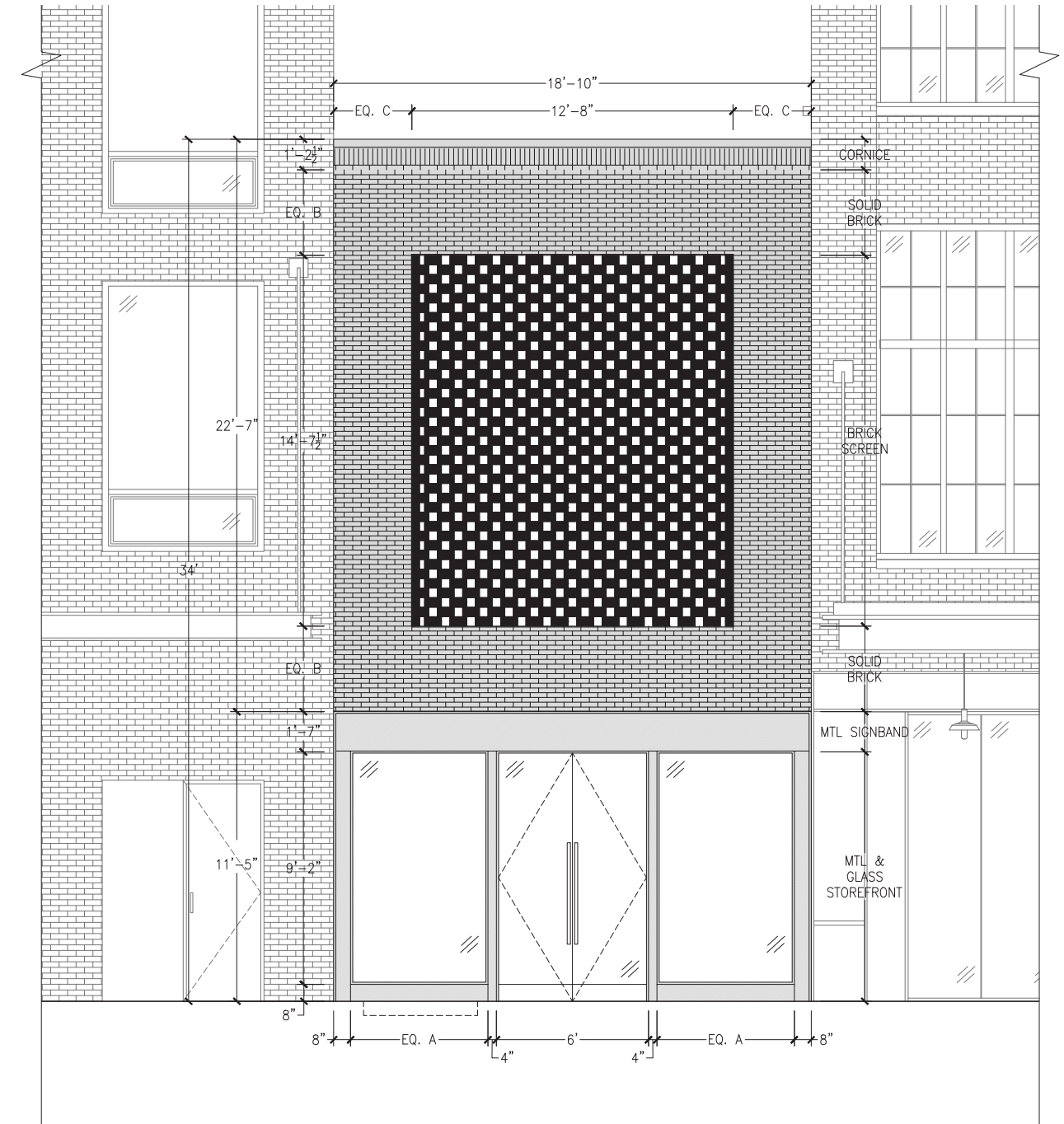

02 BUILDING FRONT ELEVATION - PROPOSED
1/4"=1'-0"

Front Facade - Existing & Proposed

406 West 13th Street

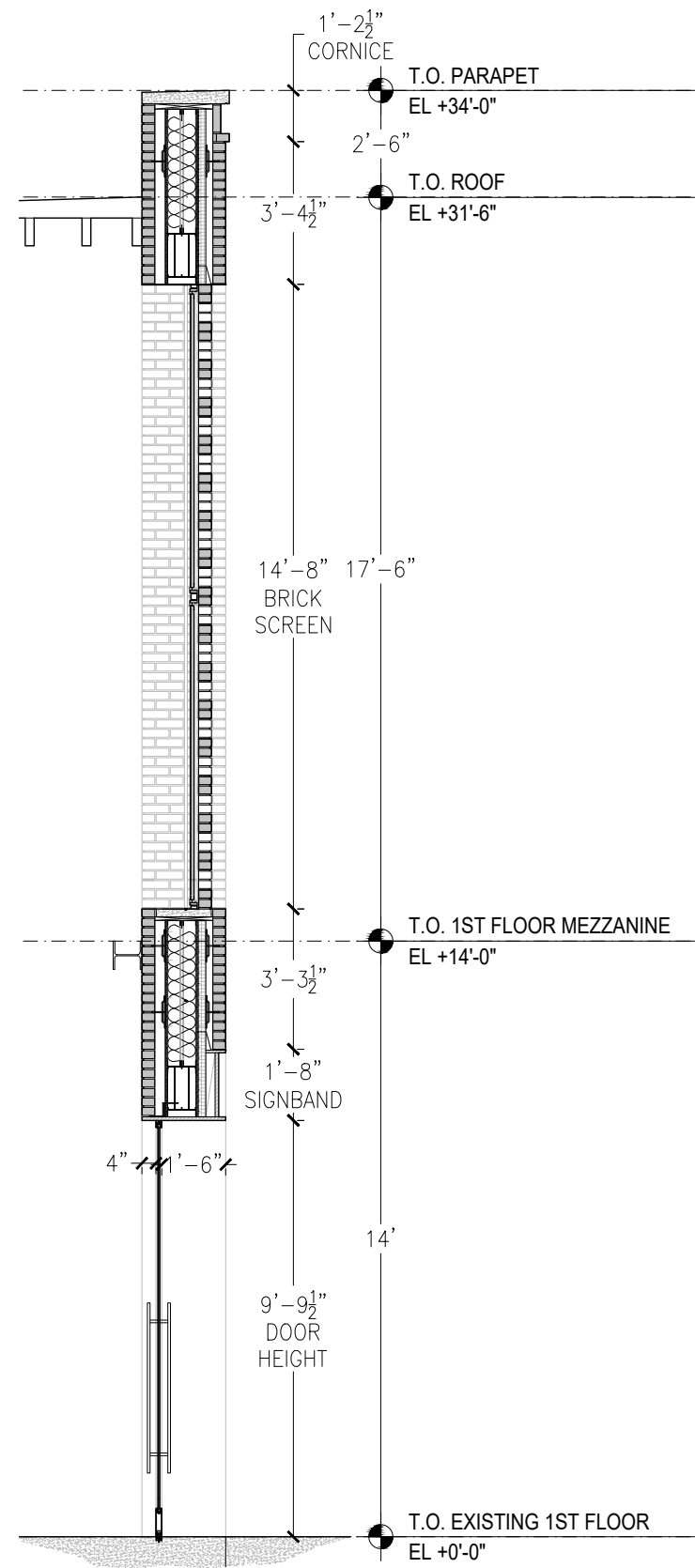

04 FRONT FACADE - WALL SECTION
3/8"=1'-0"

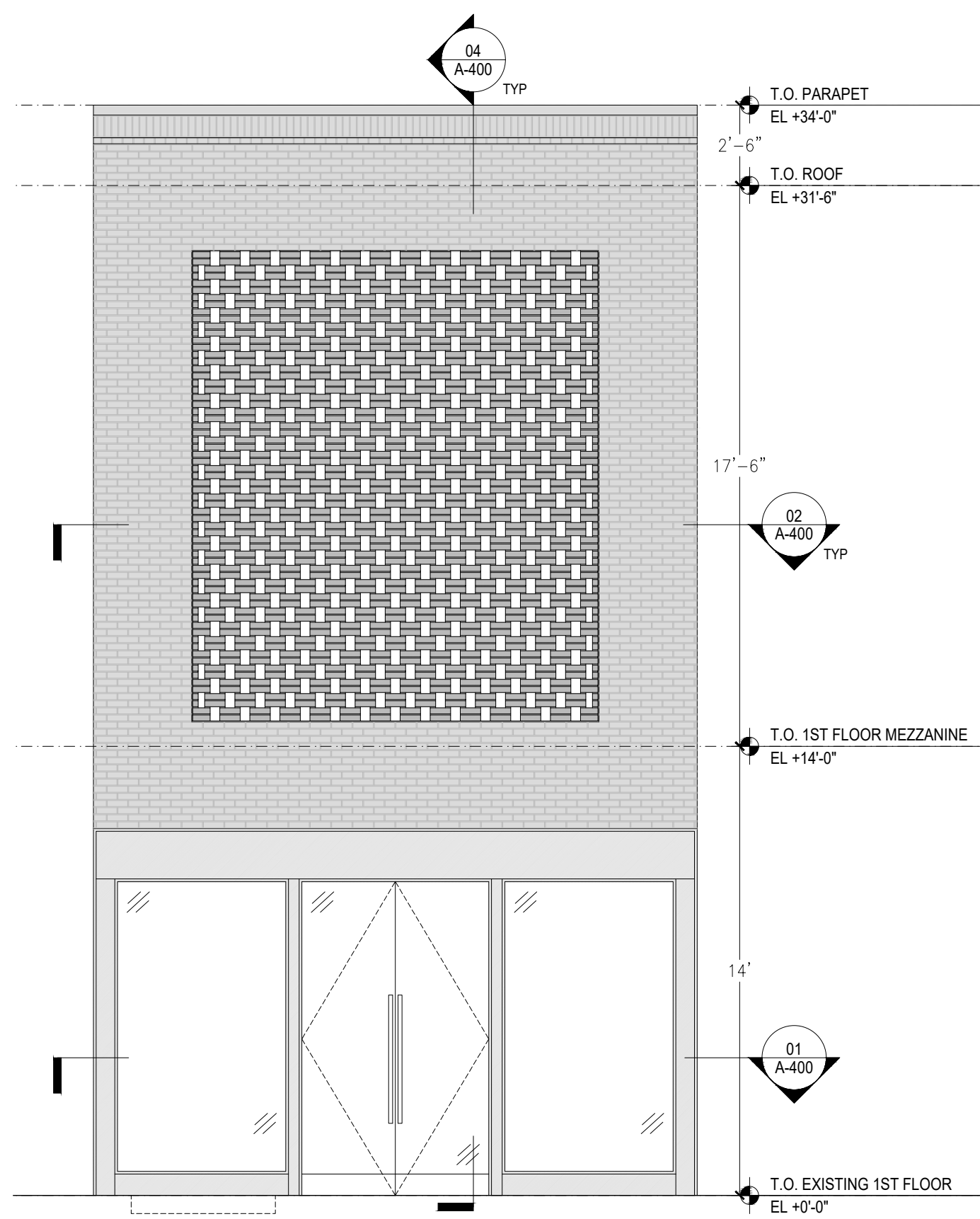

03 FRONT FACADE - ELEVATION DETAIL
3/8"=1'-0"

Exterior

Front Facade - Elevations and Details

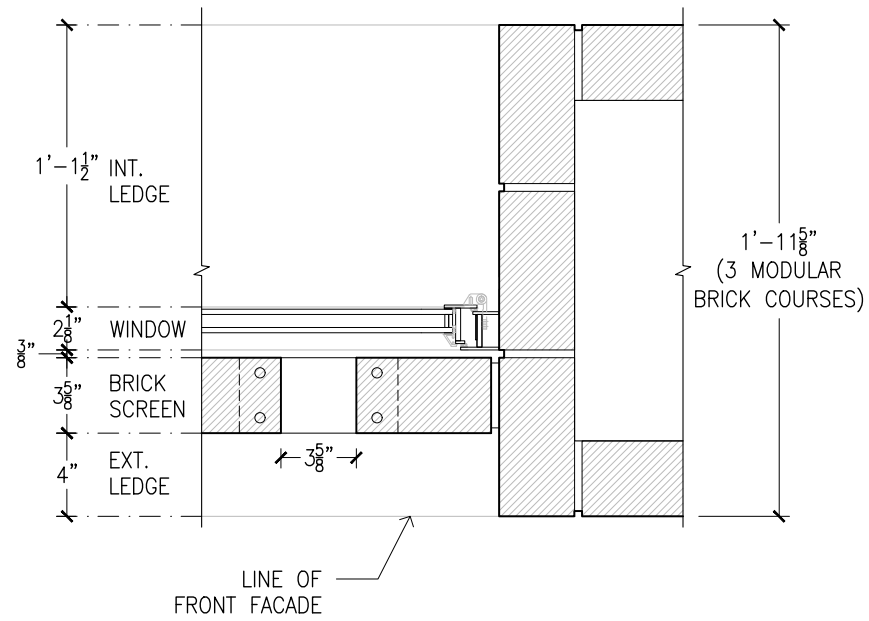

06 FRONT FACADE - PLAN DETAIL @ BRICK SCREEN
1-1/2"=1'-0"

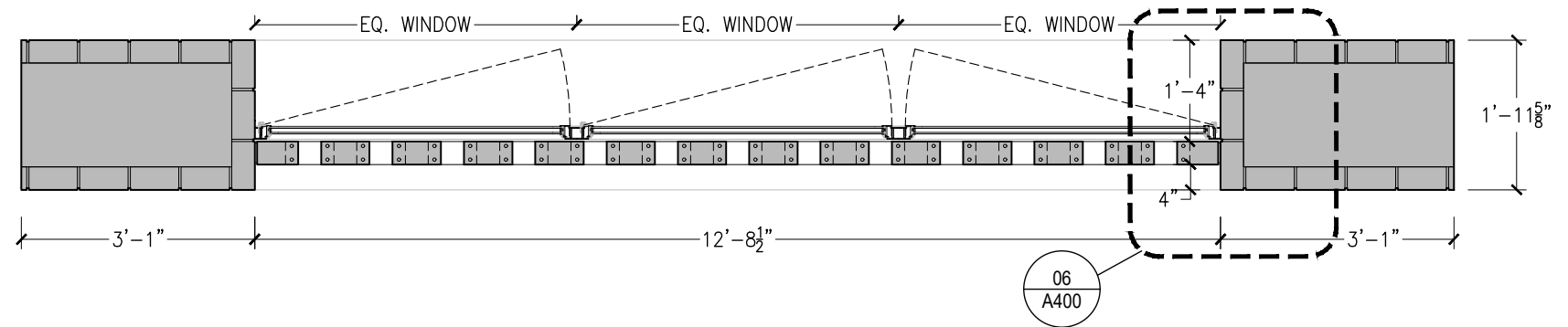

02 FRONT FACADE - PLAN DETAIL @ BRICK SCREEN
1/2"=1'-0"

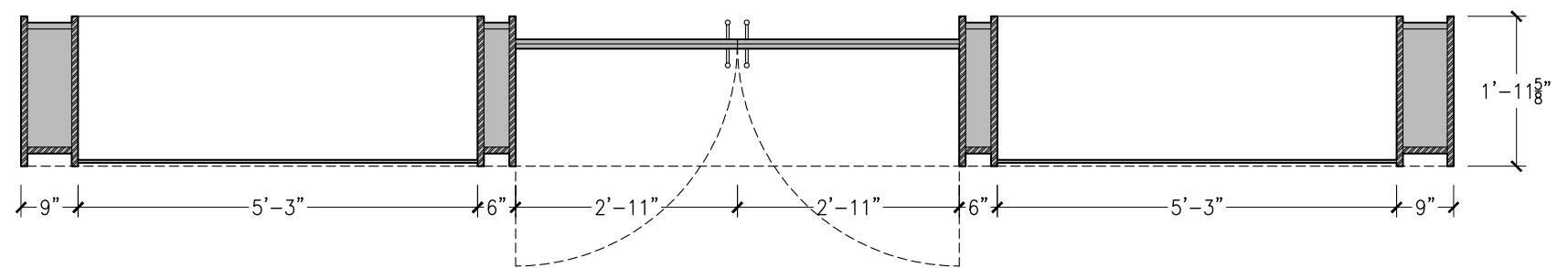

01 FRONT FACADE - PLAN DETAIL @ STOREFRONT
1/2"=1'-0"

Exterior

Front Facade - Elevations and Details

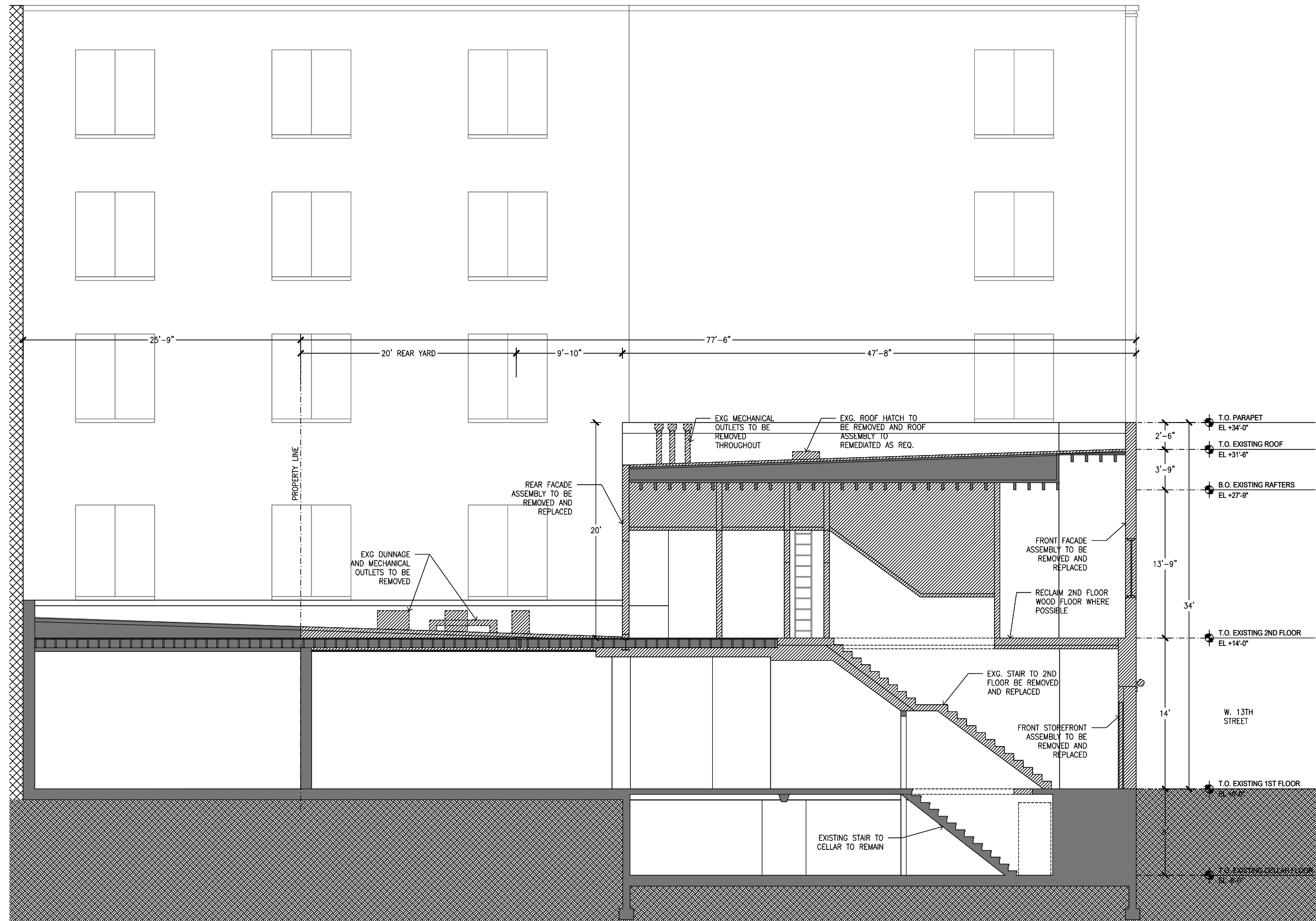

Building Section - Existing

406 West 13th Street

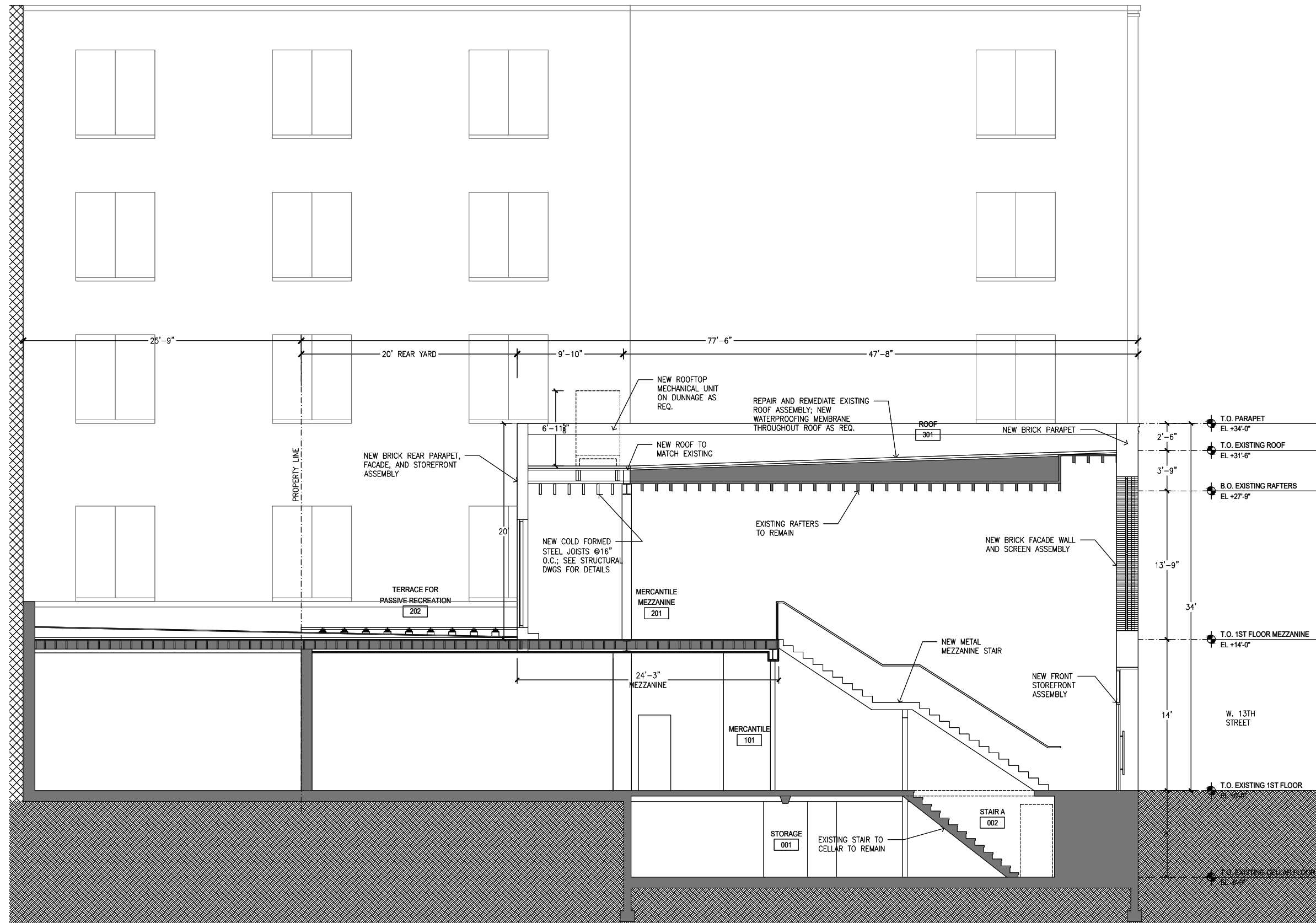

Building Section - Proposed

406 West 13th Street



Proposed Design - Street Level Night View

406 West 13th Street

THANK YOU!