

DXA studio
827- 831 Broadway
November 12, 2020

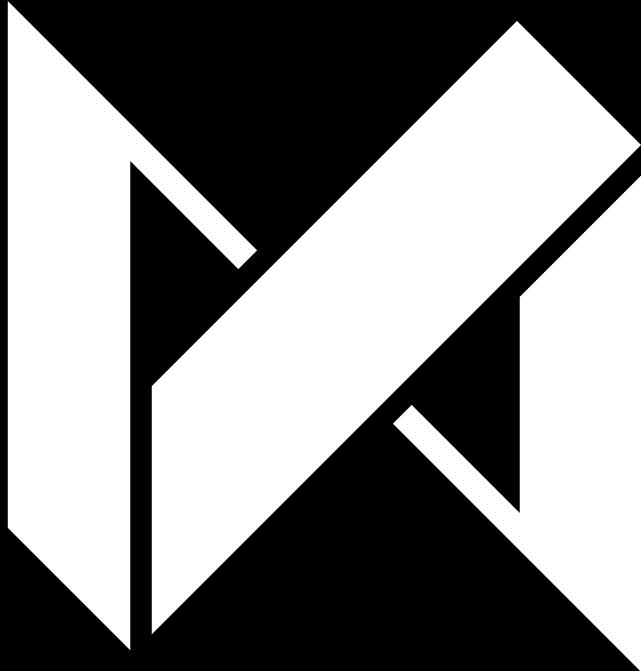

827-831 BROADWAY



STREET VIEW

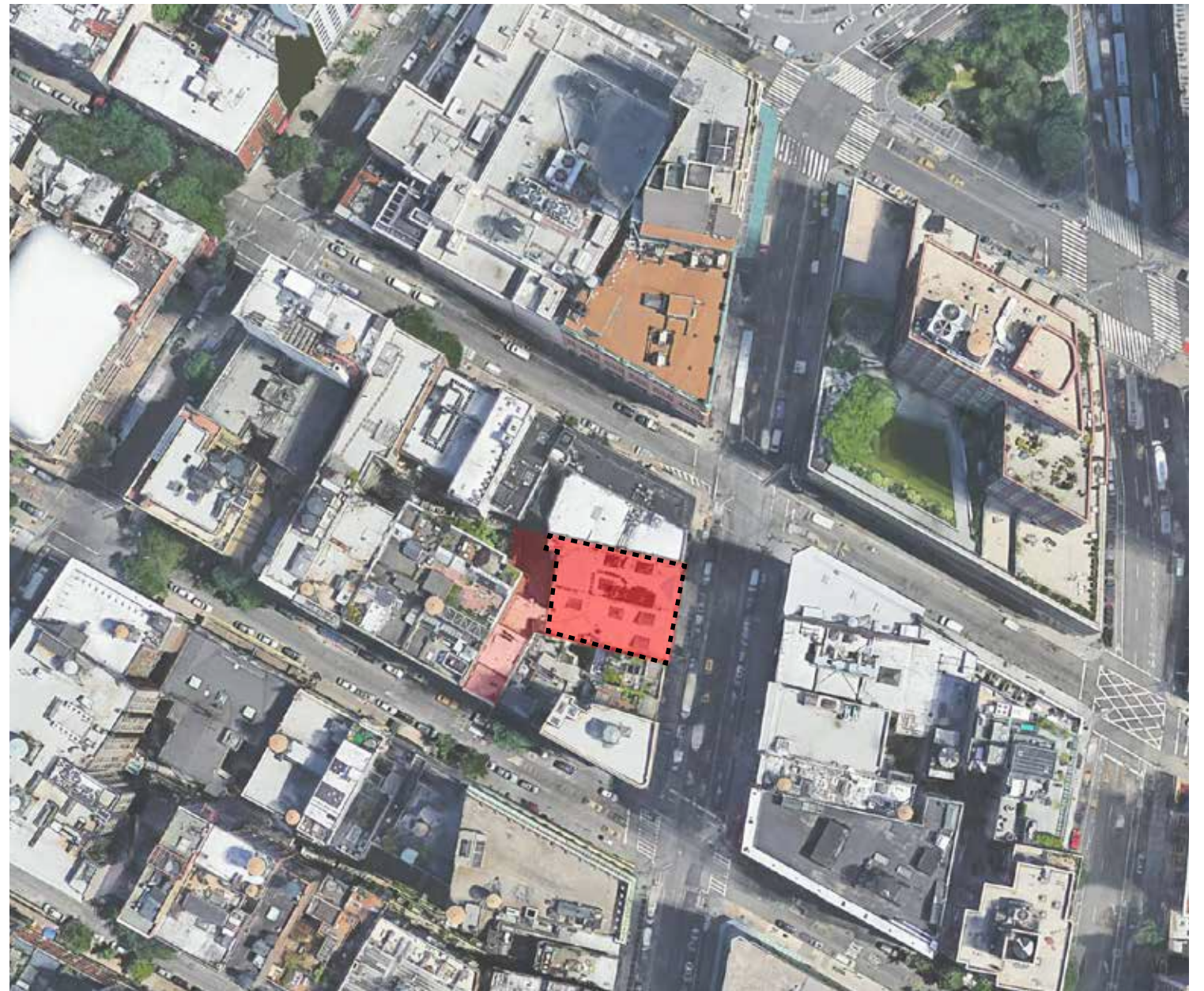

SATELLITE VIEW OF SITE

PROJECT GOALS

- CELEBRATE THE ARTISTS OF THE ABSTRACT EXPRESSIONIST MOVEMENT THAT THRUST NEW YORK TO THE WORLD STAGE, UNSEATING PARIS AS THE CENTER OF THE ART WORLD. RAISE AWARENESS AS TO THE CULTURAL SIGNIFICANCE OF WILLEM AND ELAINE DE KOONING, LARRY POONS, PAUL JENKINS, JULES OLITSKI AND HERBERT FERBER, OF THEIR WORK AND TENURE IN THE BUILDING.
- RESTORE THE EXISTING BUILDING TO ITS PERIOD OF SIGNIFICANCE WHILE RESPECTING THE ORIGINAL DESIGN.

827-831 BROADWAY · SITE CONTEXT

SCALE As Noted
CLIENT
PROJECT NUMBER 17.32
DATE November 12 2020



DXA studio 894 6th Avenue
 5th Floor
 NYC 10001
 T 212 874 0567
 dxastudio.com



SITE ANALYSIS & EXISTING CONDITIONS

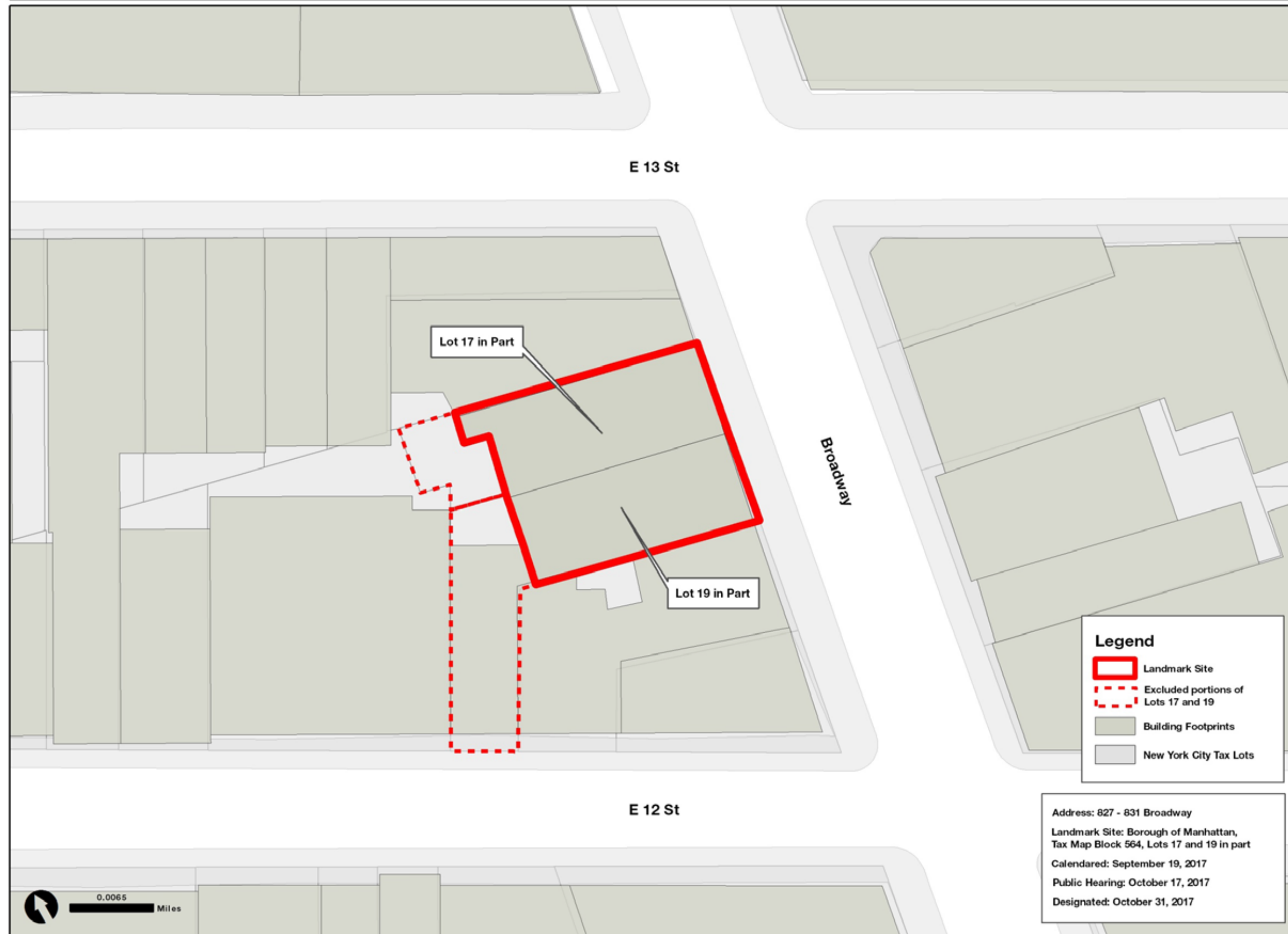

Graphic Source: MapPLUTO, Edition 16v2, Author: New York City Landmarks Preservation Commission, SRM, Date: 10.27.2017

827-831 BROADWAY · SITE DESIGNATION

SCALE As Noted
 CLIENT
 PROJECT NUMBER 17.32
 DATE November 12 2020



DXA studio

894 6th Avenue
 5th Floor
 NYC 10001
 T 212 874 0567

dxastudio.com



TAX PHOTOS BUILDING - 827 & 831 CIRCA 1940



TAX PHOTOS BUILDING - 827 & 831 CIRCA 1980



DXA studio

894 6th Avenue
5th Floor
NYC 10001
T 212 874 0567

dxastudio.com

827-831 BROADWAY · HISTORIC TAX PHOTOS

SCALE As Noted
CLIENT
PROJECT NUMBER 17.32
DATE November 12 2020



BROADWAY FACADE & STOREFRONT

827-831 BROADWAY · PHOTOS OF EXISTING FACADES

SCALE As Noted
 CLIENT
 PROJECT NUMBER 17.32
 DATE November 12 2020



DXA studio
 894 6th Avenue
 5th Floor
 NYC 10001
 T 212 874 0567
 dxastudio.com



BROADWAY ELEVATION PHOTOMONTAGE



DXA studio
 894 6th Avenue
 5th Floor
 NYC 10001
 T 212 874 0567
 dxastudio.com

827-831 BROADWAY · SURROUNDING BUILDINGS

SCALE As Noted
CLIENT
PROJECT NUMBER 17.32
DATE November 12 2020



1



2



3



4



5



6



7



8



9



827-831 BROADWAY · SURROUNDING BUILDINGS - DIVERSITY OF THE NEIGHBORHOOD



DXA studio
894 6th Avenue
5th Floor
NYC 10001
T 212 874 0567
dxastudio.com

SCALE As Noted
CLIENT
PROJECT NUMBER 17.32
DATE November 12 2020

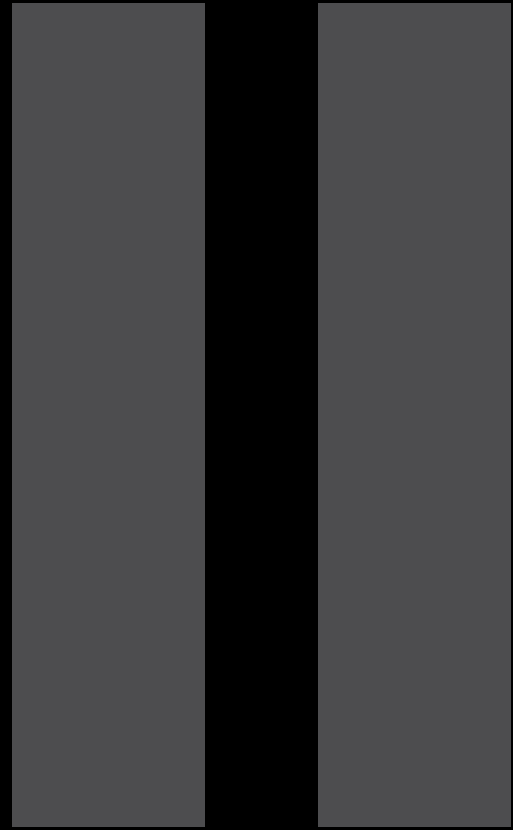

MASSING & DESIGN

INITIAL PROPOSAL 01.09.18 + APPROVED DESIGN 05.15.18

NARRATIVE OF CHANGES BETWEEN THE INITIAL PROPOSAL PRESENTED TO THE LPC COMMISSION ON 01.09.18, AND THE APPROVED DESIGN THAT WAS APPROVED BY THE LPC COMMISSION ON 05.15.18.

- [01.09.18 LPC PRESENTATION COMMENT MADE](#) - THE MASSING OF THE ADDITION IS **OUT OF SCALE** WITH THE NEIGHBORHOOD AND THE **ADDITION IS TOO VISIBLE**.
- [05.15.18 LPC PRESENTATION COMMENT ADDRESSED](#) - THE MASSING OF THE ADDITION WAS **REDUCED IN HEIGHT** AND **SETBACK 8'-0"** FURTHER FROM THE STREET TO REDUCE VISIBILITY. THE REMAINING **BULK** WAS **RELOCATED** OVER TO THE NON-LANDMARKED PORTION OF THE SITE.

- [01.09.18 LPC PRESENTATION COMMENT MADE](#) - THE FACETED GLASS FACADE IS JARRING AS A GESTURE AND **DOES NOT RELATE** ENOUGH TO THE **EXISTING LANDMARK BUILDING**.
- [05.15.18 LPC PRESENTATION COMMENT ADDRESSED](#) - THE **FACADE** WAS **REVISED** TO A **SLUMPED GLASS** EXPRESSION THAT ECHOS THE PROPORTIONS AND FENESTRATION OF THE **HISTORIC** LANDMARK BUILDING BELOW.

- [01.09.18 LPC PRESENTATION COMMENT MADE](#) - THE GLAZING OF THE FACETED DESIGN IS **TOO REFLECTIVE**.
- [05.15.18 LPC PRESENTATION COMMENT ADDRESSED](#) - THE GLAZING **REFLECTIVITY** WAS **REDUCED**.



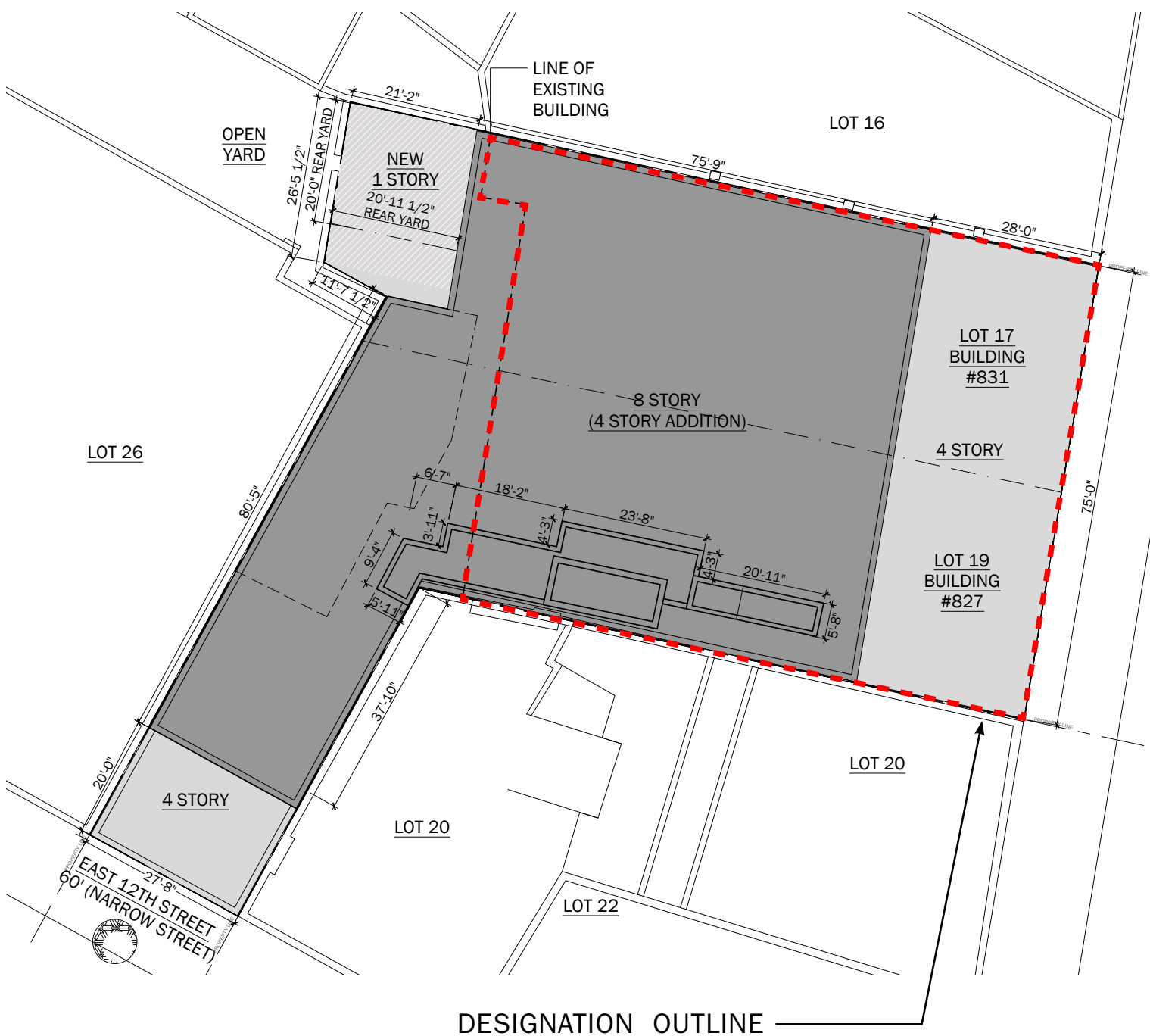

ZONING SITE PLAN - INITIAL PROPOSAL_01.09.18

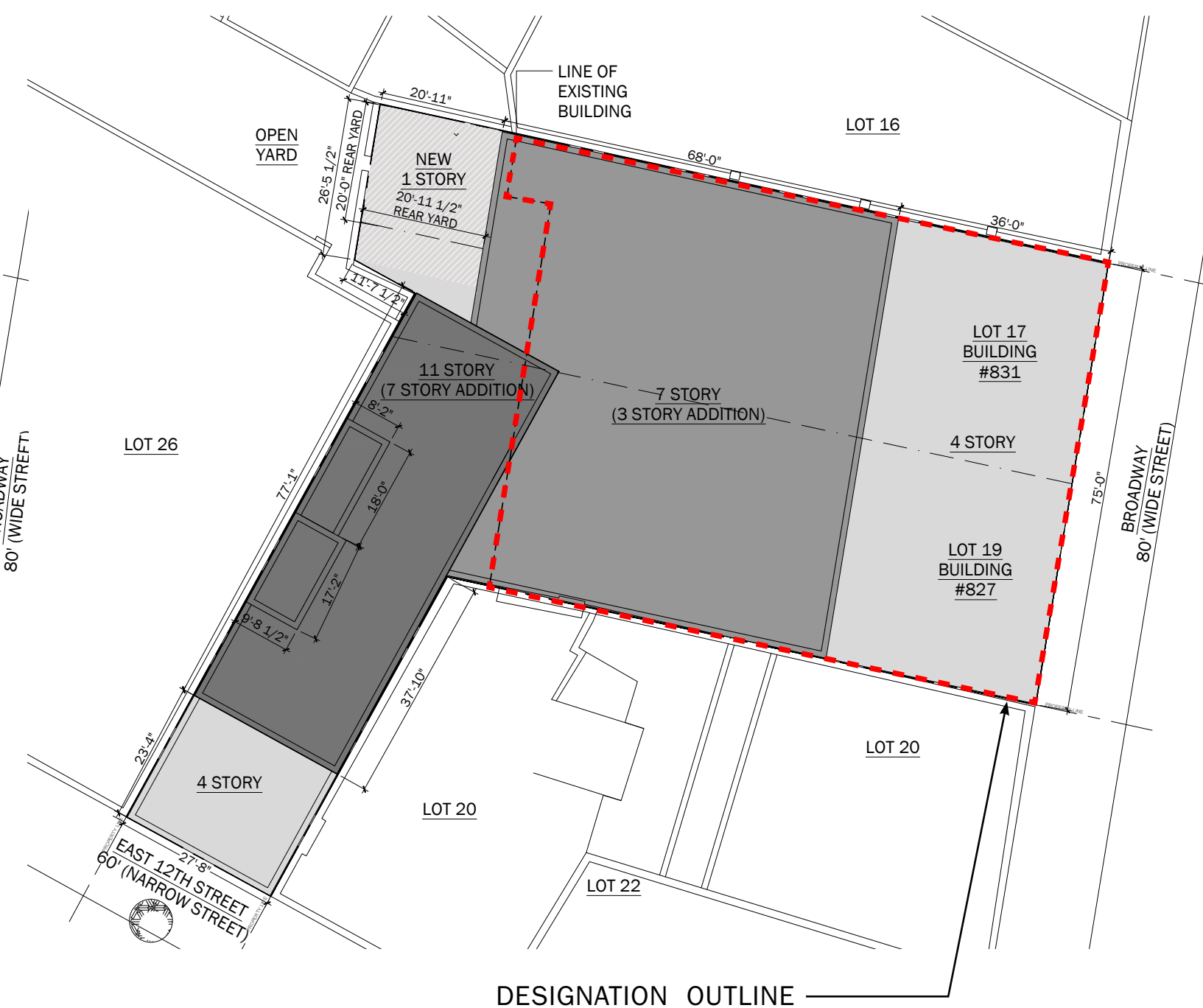

ZONING SITE PLAN - APPROVED DESIGN_05.15.18

827-831 BROADWAY · ZONING SITE PLAN



DXA studio
 894 6th Avenue
 5th Floor
 NYC 10001
 T 212 874 0567
 dxastudio.com

SCALE As Noted
CLIENT
PROJECT NUMBER 17.32
DATE November 12 2020

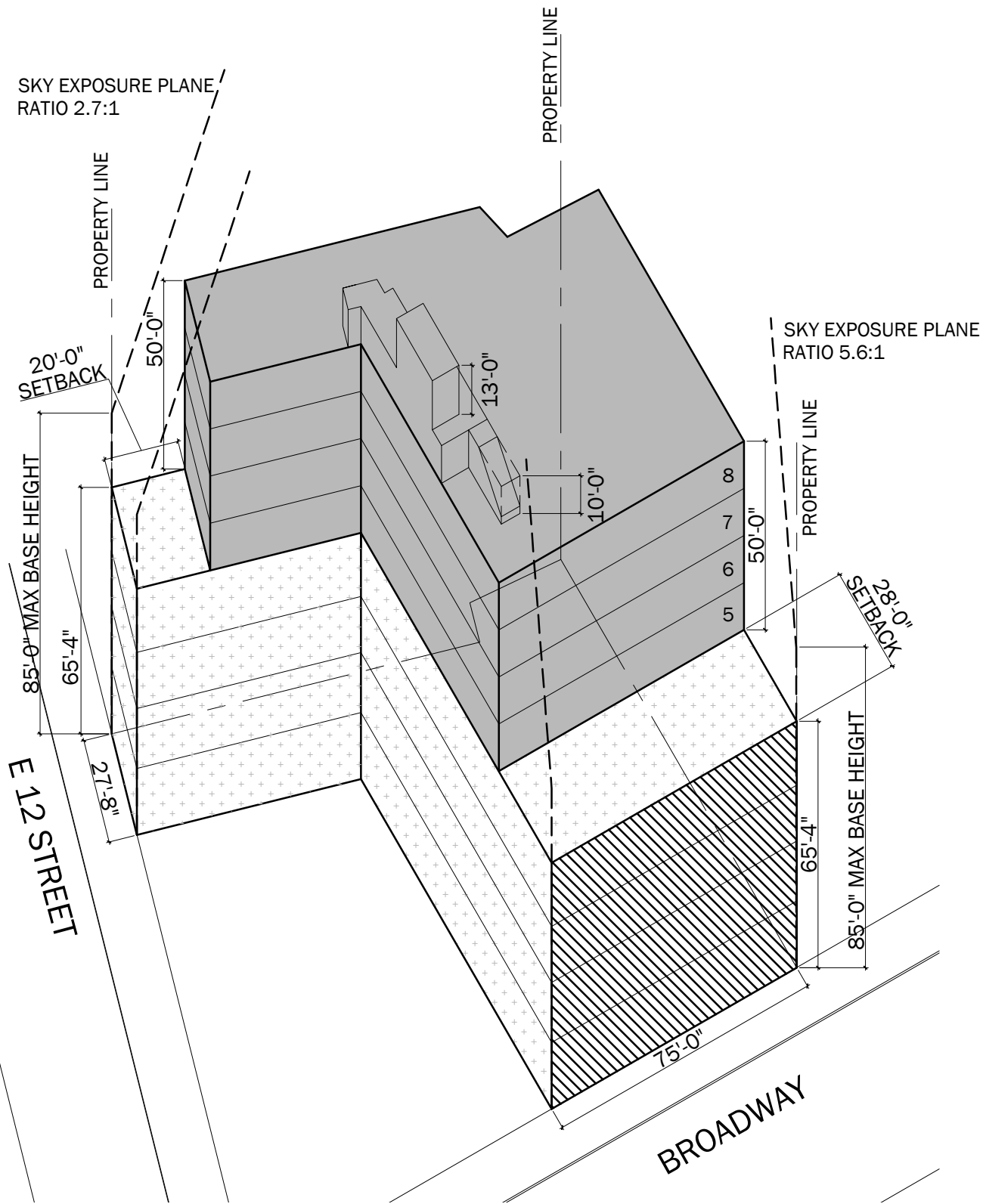

ZONING AXONOMETRIC - INITIAL PROPOSAL_01.09.18

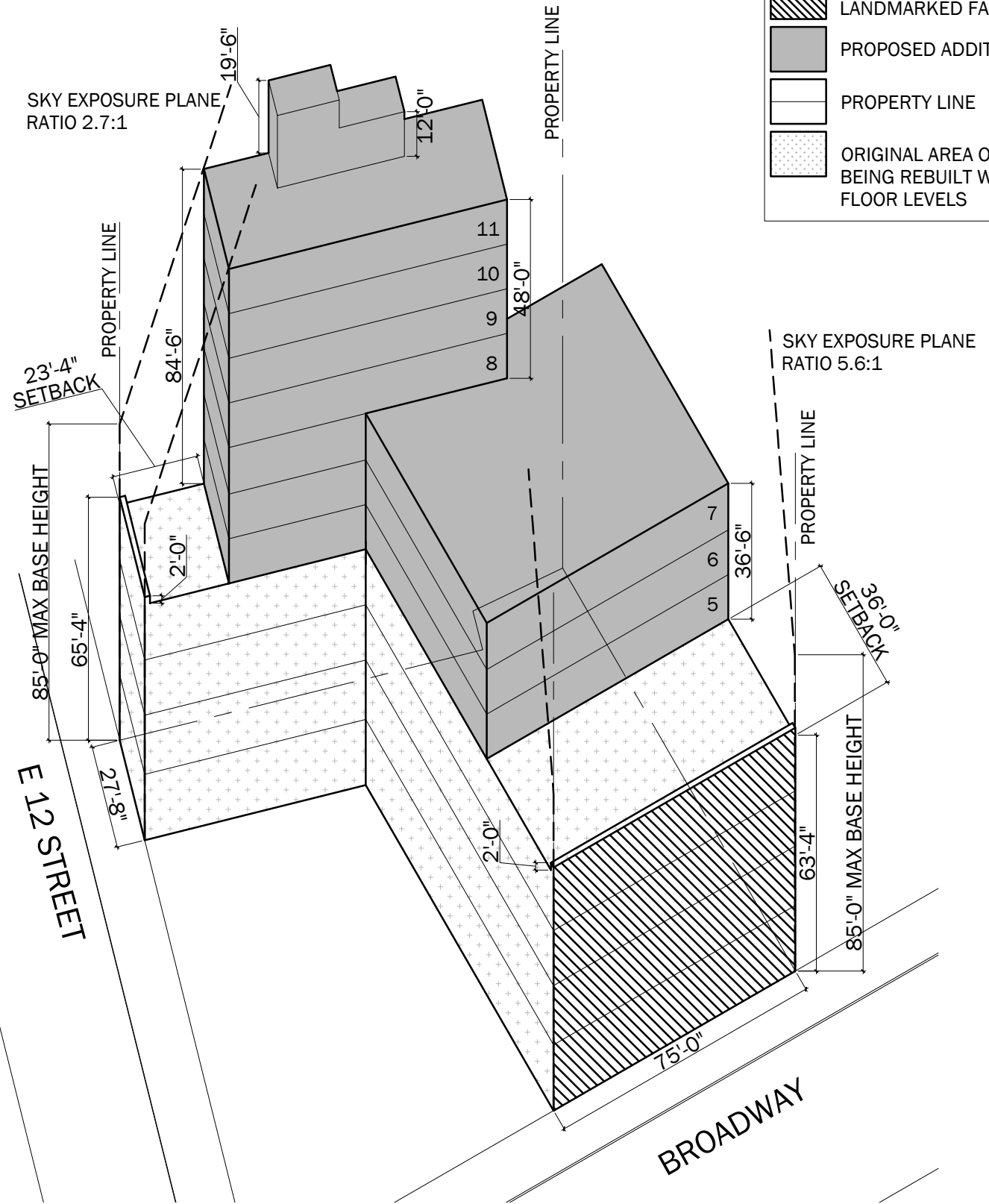

ZONING AXONOMETRIC - APPROVED DESIGN_05.15.18

ZONING LEGEND	
	RESTORED LANDMARKED FACADE
	PROPOSED ADDITION
	PROPERTY LINE
	ORIGINAL AREA OF BUILDING BEING REBUILT WITH SAME FLOOR LEVELS



DXA studio
 894 6th Avenue
 5th Floor
 NYC 10001
 T 212 874 0567
 dxastudio.com

827-831 BROADWAY · AXONOMETRIC DIAGRAMS

SCALE As Noted
 CLIENT
 PROJECT NUMBER 17.32
 DATE November 12 2020



827-831 BROADWAY - STREET VIEW FROM BROADWAY AND EAST 13TH STREET - APPROVED DESIGN_05.15.18



DXA studio
894 6th Avenue
5th Floor
NYC 10001
T 212 874 0567
dxastudio.com

SCALE As Noted
CLIENT
PROJECT NUMBER 17.32
DATE November 12 2020



827-831 BROADWAY - STREET VIEW FROM BROADWAY AND EAST 13TH STREET - INITIAL PROPOSAL_01.09.18



DXA studio
894 6th Avenue
5th Floor
NYC 10001
T 212 874 0567
dxastudio.com

SCALE As Noted
CLIENT
PROJECT NUMBER 17.32
DATE November 12 2020



HISTORY & INSPIRATION

**PROMINENT ARTISTS OF
THE NEW YORK SCHOOL**



JACKSON POLLOCK



MARK ROTHKO



FRANZ KLINE



ARSHILE GORKY



ADOLF GOTTLIEB



HELEN FRANKENTHALER

**827-831 BROADWAY
CONTRIBUTING ARTISTS**



LARRY POONS



PAUL JENKINS

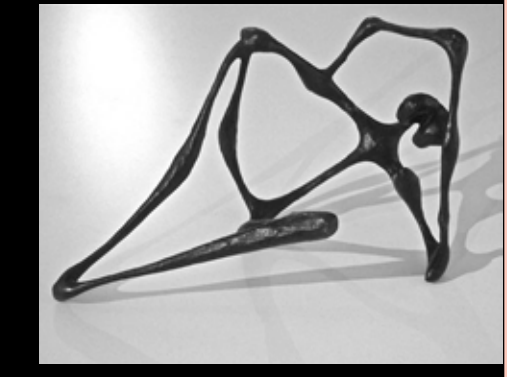

HERBERT FERBER



WILLEM DE KOONING



ELAINE DE KOONING



JULES OLITSKI



827-831 BROADWAY · HISTORY & INSPIRATION: ABSTRACT EXPRESSIONISM



DXA studio
894 6th Avenue
5th Floor
NYC 10001
T 212 874 0567
dxastudio.com

SCALE As Noted
CLIENT
PROJECT NUMBER 17.32
DATE November 12 2020

WILLEM DE KOONING IN
BROADWAY STUDIO 1958 - 1963

**BLACK & WHITE
ABSTRACT
- LATE 1940s**



**FIGURATIVE
REPRESENTATION
- EARLY 1950s**

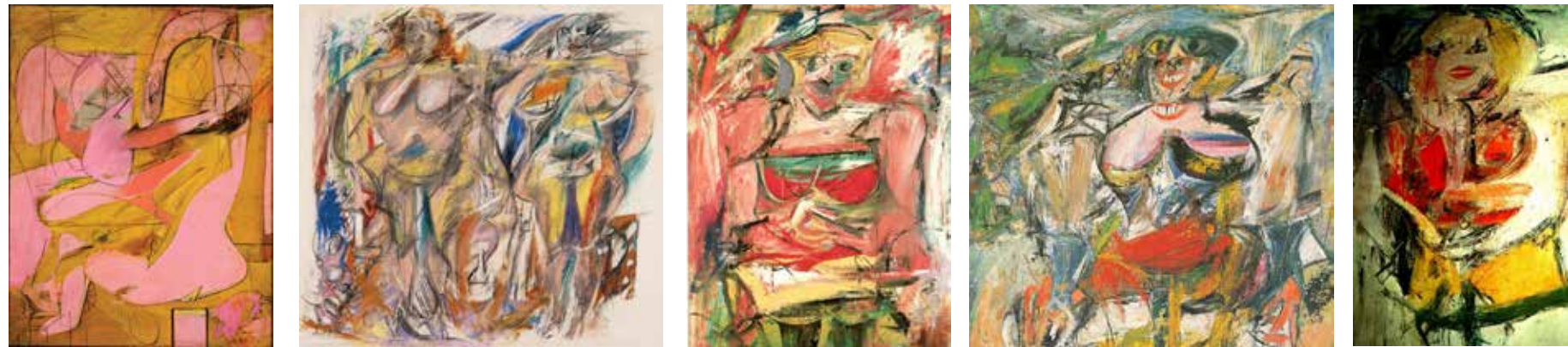

**URBAN LANDSCAPE
REPRESENTATION
- LATE 1950s**



**RURAL LANDSCAPE
REPRESENTATION
- EARLY 1960s**



**PAINTINGS WILLEM DE KOONING
PRODUCED IN 831 BROADWAY
- ROSY - FINGERED DAWN AT LOUSE POINT
- DOOR TO THE RIVER**

DE KOONING AS A MICROCOSM OF THE MOVEMENT

827-831 BROADWAY · HISTORY & INSPIRATION - DE KOONING



DXA studio 894 6th Avenue
5th Floor
NYC 10001
T 212 874 0567
dxastudio.com

SCALE As Noted
CLIENT
PROJECT NUMBER 17.32
DATE November 12 2020



PAINTING AS CONSTRUCTION: WILLEM DE KOONING - EXCAVATION

827-831 BROADWAY · HISTORY & INSPIRATION - DE KOONING

SCALE	As Noted
CLIENT	
PROJECT NUMBER	17.32
DATE	November 12 2020



DXA studio

894 6th Avenue
5th Floor
NYC 10001
T 212 874 0567

dxastudio.com



FIGURATIVE REPRESENTATION;
CALLIGRAPHIC LINES DEFINE ANATOMICAL
PARTS FORMING COMPLEX MULTI-FIGURE
GROUPINGS

VERTICAL ALIGNMENT: DIVIDING
PAINTING INTO APPROXIMATING
COLUMNS

EXPRESSIVE BRUSHWORK WITH
BRIGHT BACKGROUND TEXTURES

ORGANIZATION OF SPACE INTO
LOOSE SLIDING PLANES WITH
OPEN CONTOURS

DETAIL 1

827-831 BROADWAY · HISTORY & INSPIRATION - DE KOONING

SCALE As Noted
CLIENT
PROJECT NUMBER 17.32
DATE November 12 2020



DXA studio

dxastudio.com

894 6th Avenue
5th Floor
NYC 10001
T 212 874 0567

19

NW

**FACADE DESIGN
& COMPARATIVE
VISIBILITY
STUDIES**



827-831 BROADWAY - STREET VIEW WEST - APPROVED DESIGN_05.15.18



DXA studio

dxastudio.com

894 6th Avenue
5th Floor
NYC 10001
T 212 874 0567

SCALE	As Noted
CLIENT	
PROJECT NUMBER	17.32
DATE	November 12 2020

21



827-831 BROADWAY - STREET VIEW WEST - INITIAL PROPOSAL_01.09.18



DXA studio

dxastudio.com

894 6th Avenue
5th Floor
NYC 10001
T 212 874 0567

SCALE	As Noted
CLIENT	
PROJECT NUMBER	17.32
DATE	November 12 2020

22

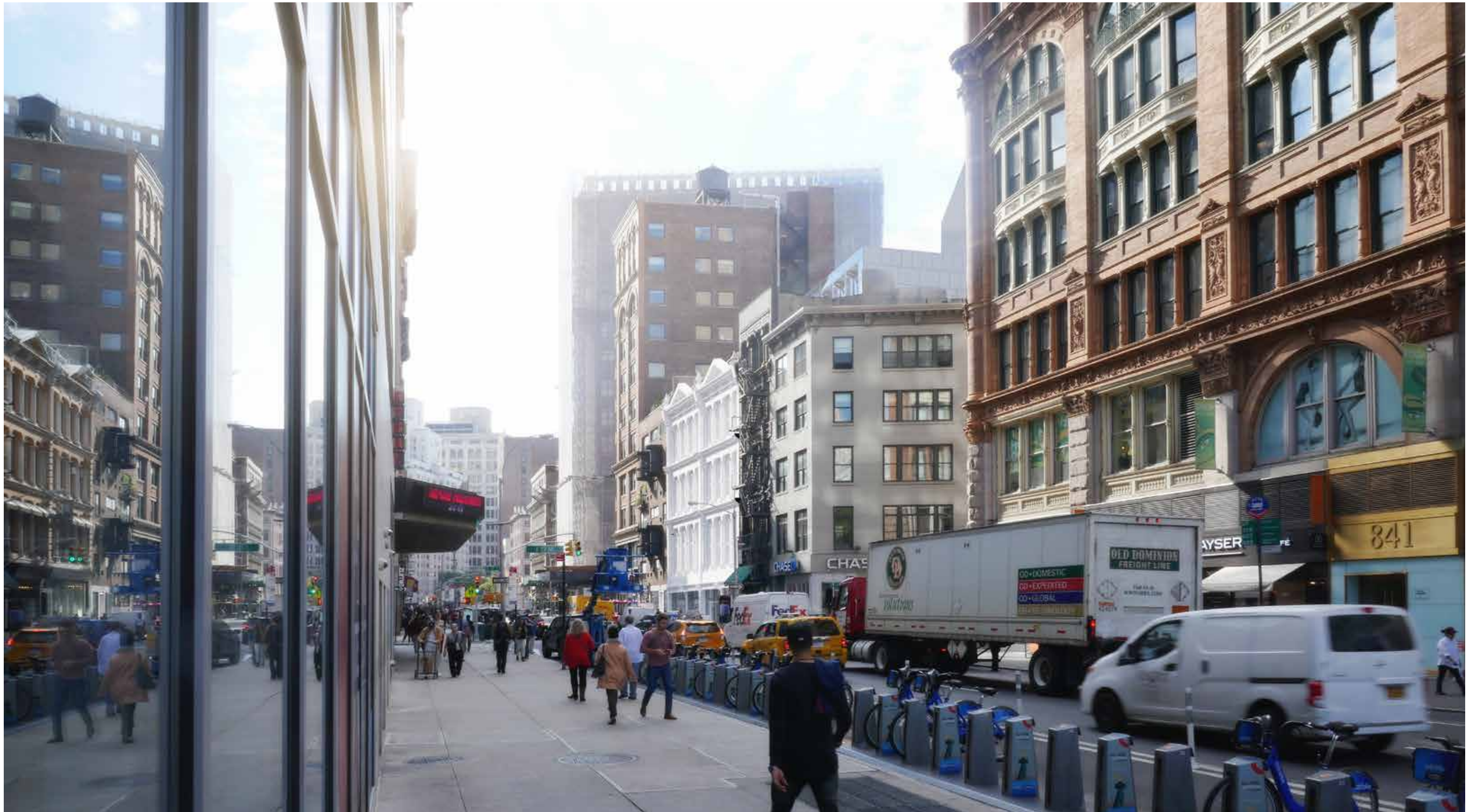

827-831 BROADWAY - STREET VIEW FROM UNION SQUARE - APPROVED DESIGN_05.15.18



DXA studio

894 6th Avenue
5th Floor
NYC 10001
T 212 874 0567

dxastudio.com

SCALE As Noted
CLIENT
PROJECT NUMBER 17.32
DATE November 12 2020

23

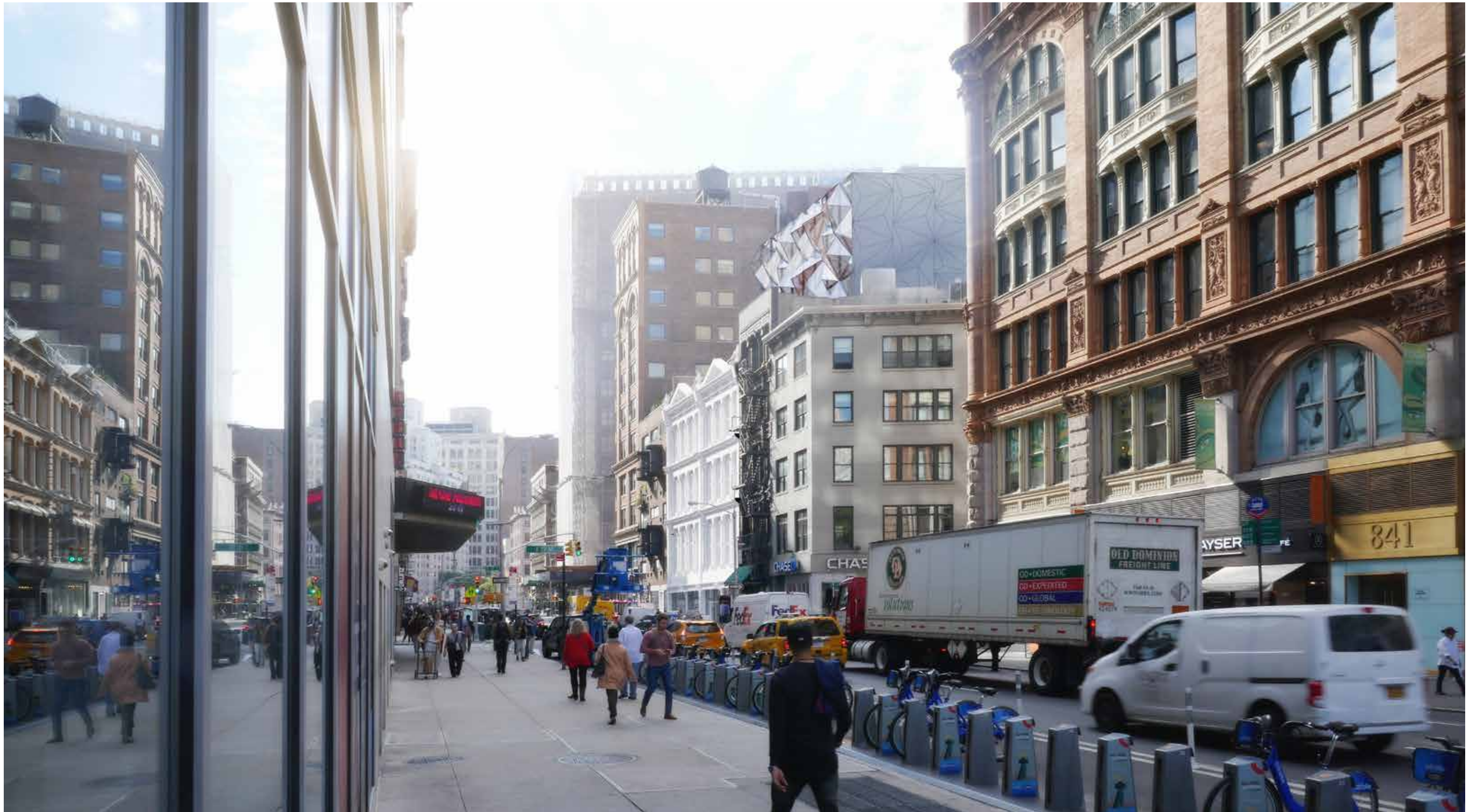

827-831 BROADWAY - STREET VIEW FROM UNION SQUARE - INITIAL PROPOSAL_01.09.18



DXA studio

894 6th Avenue
5th Floor
NYC 10001
T 212 874 0567

dxastudio.com

SCALE As Noted
CLIENT
PROJECT NUMBER 17.32
DATE November 12 2020

24



827-831 BROADWAY - FIFTH FLOOR TERRACE VIEW - DAY - APPROVED DESIGN_05.15.18



DXA studio

894 6th Avenue
5th Floor
NYC 10001
T 212 874 0567

dxastudio.com

SCALE	As Noted
CLIENT	
PROJECT NUMBER	17.32
DATE	November 12 2020

25

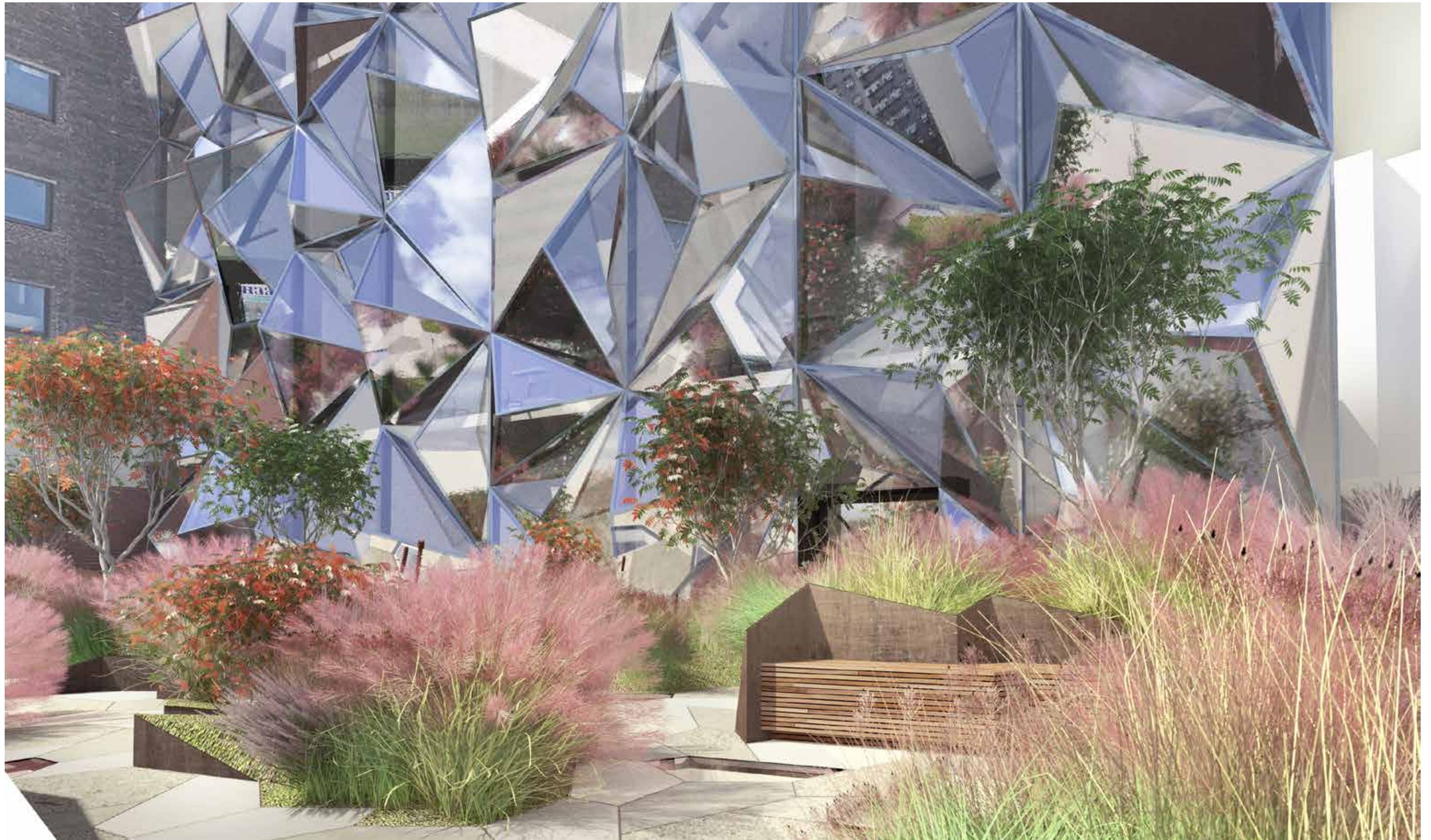

827-831 BROADWAY - FIFTH FLOOR TERRACE VIEW - DAY - INITIAL PROPOSAL_01.09.18



DXA studio
894 6th Avenue
5th Floor
NYC 10001
T 212 874 0567
dxastudio.com

SCALE As Noted
CLIENT
PROJECT NUMBER 17.32
DATE November 12 2020



827-831 BROADWAY - FIFTH FLOOR TERRACE VIEW - NIGHT - APPROVED DESIGN_05.15.18



DXA studio

894 6th Avenue
5th Floor
NYC 10001
T 212 874 0567

dxastudio.com

SCALE	As Noted
CLIENT	
PROJECT NUMBER	17.32
DATE	November 12 2020

27

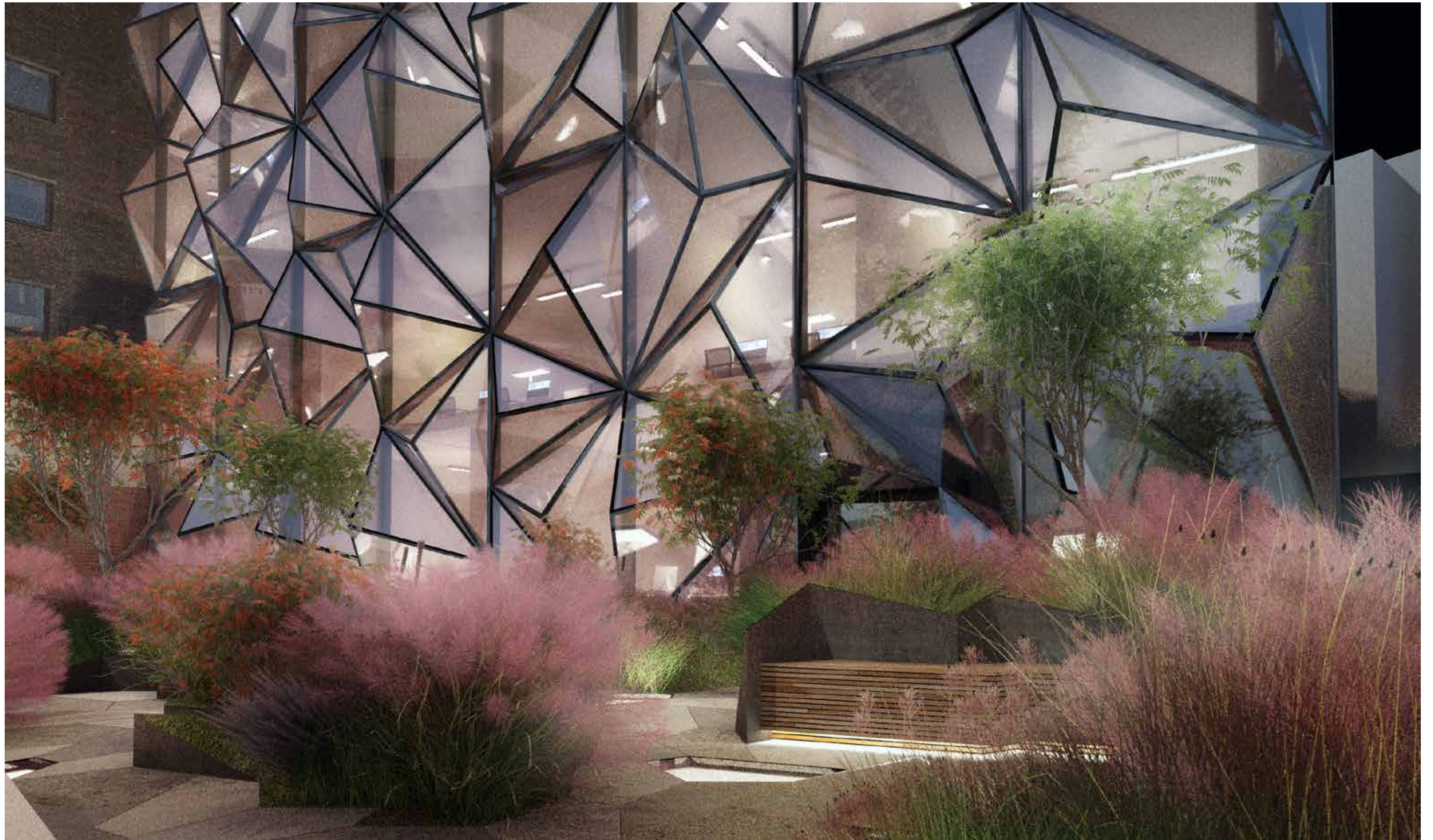

827-831 BROADWAY - FIFTH FLOOR TERRACE VIEW - NIGHT - INITIAL PROPOSAL_01.09.18



DXA studio

894 6th Avenue
5th Floor
NYC 10001
T 212 874 0567

dxastudio.com

SCALE	As Noted
CLIENT	
PROJECT NUMBER	17.32
DATE	November 12 2020

28



827-831 BROADWAY - BROADWAY FACADE - APPROVED DESIGN_05.15.18

SCALE As Noted
CLIENT
PROJECT NUMBER 17.32
DATE November 12 2020



DXA studio
894 6th Avenue
5th Floor
NYC 10001
T 212 874 0567
dxastudio.com



827-831 BROADWAY - BROADWAY FACADE - INITIAL PROPOSAL_01.09.18



DXA studio

894 6th Avenue
5th Floor
NYC 10001
T 212 874 0567

dxastudio.com

SCALE	As Noted
CLIENT	
PROJECT NUMBER	17.32
DATE	November 12 2020

30



1.



2.



3.



4.



5.



6.

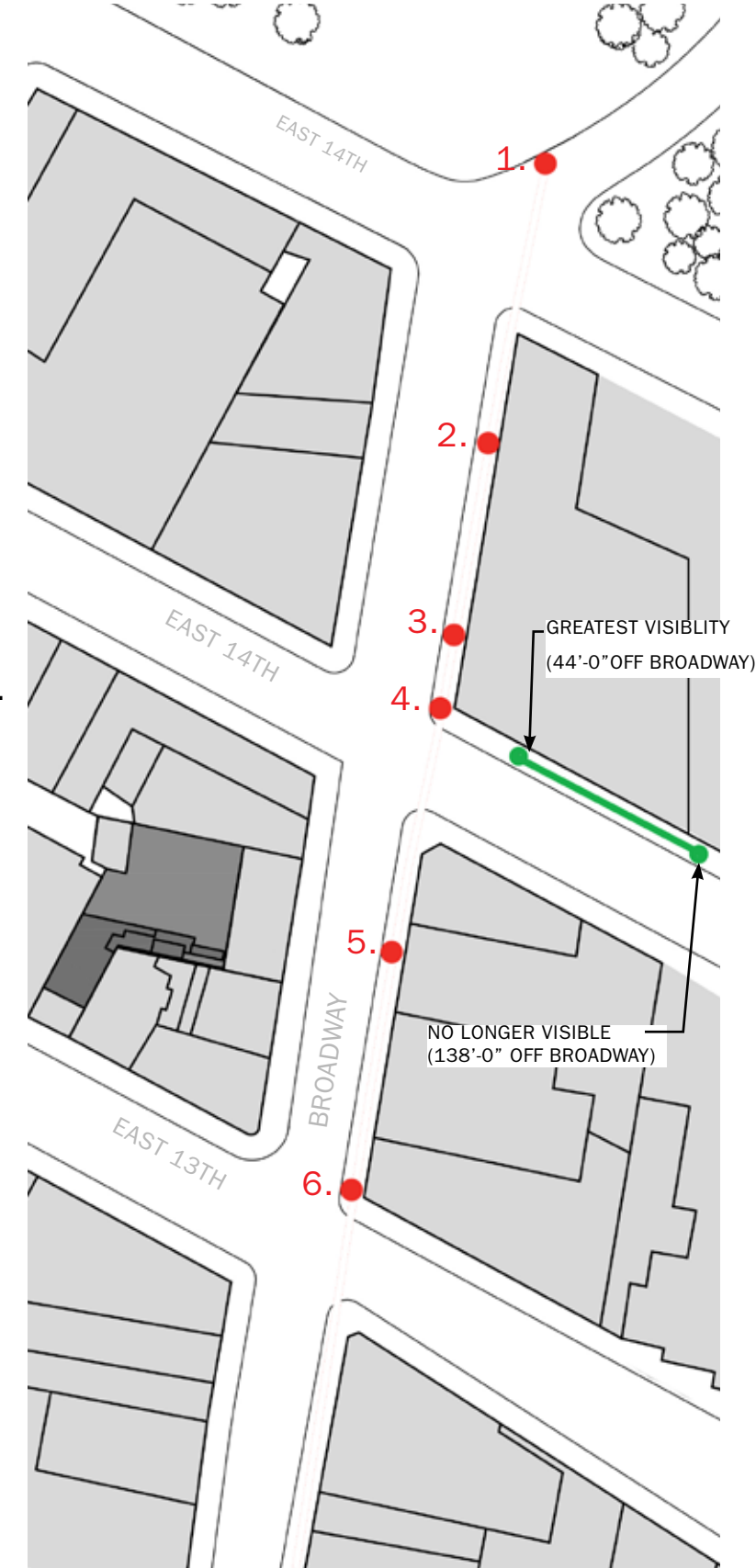

VIEW LOCATIONS

827-831 BROADWAY - VISIBILITY STUDIES - APPROVED DESIGN_05.15.18



DXA studio
 894 6th Avenue
 5th Floor
 NYC 10001
 T 212 874 0567
 dxastudio.com

SCALE As Noted
CLIENT
PROJECT NUMBER 17.32
DATE November 12 2020

31



14TH STREET & BROADWAY



12TH STREET & BROADWAY



DXA studio

894 6th Avenue
5th Floor
NYC 10001
T 212 874 0567

dxastudio.com

827-831 BROADWAY - VISIBILITY STUDIES - INITIAL PROPOSAL_01.09.18

SCALE As Noted
CLIENT
PROJECT NUMBER 17.32
DATE November 12 2020

32

W

**RESTORATION
WORK**



TUCKAHOE MARBLE QUOIN



EXISTING ELEVATION

REMOVE EXISTING RAILING AND REPLACE WITH GLASS RAILING

CLEAN EXPOSED MARBLE WITH SURE KLEAN 942 LIMESTONE AND MARBLE CLEANER OR EQUAL. TESTING FIRST AND FOLLOWING MANUFACTURERS INSTRUCTIONS. WATER RINSE WITH FAN TIPPED NOZZLE AT NO MORE THAN 250 PSI (TYP.)

REMOVE PAINT FROM MARBLE USING PROSOCO ENVIROKLEAN SAFETY PEEL 1 OR EQUAL, TESTING FIRST AND FOLLOWING MANUFACTURERS INSTRUCTIONS (TYP.)

INTERACTIVE PLAQUE

REPAIR AND REPOINT MARBLE FACADE (TYP.) AND TRIM AS REQ. WITH RESTORATION MORTAR, TO MATCH EXISTING IN COLOR, TEXTURE, DETAIL, AND TOOLING, AND FOLLOWING MANUFACTURERS INSTRUCTIONS.

RESET AND REANCHOR DECORATIVE URNS AT CORNICE AND CORNICE BRACKETS, AS REQ. USING STAINLESS STEEL ANCHORS AND PINS AND RETAINING AND REUSING ORIGINAL MATERIALS.



PROPOSED ELEVATION

REPOINT MARBLE FACADE AS REQ. HAND RAKE JOINTS AND REPOINT TO MATCH EXISTING IN COLOR, TEXTURE, COMPOSITION AND TOOLING (TYP.)

UPLIGHTING ON EACH COLUMN (TYPICAL), FIXTURE COLOR TO MATCH FACADE

REPLACE WINDOWS WITH PAIRED 1 OVER 1 - TYPICAL
REMOVE AWNINGS ON SECOND FLOOR WINDOWS

KEEP SECOND FLOOR WINDOWS AND JUILETTE BALCONIES ON 827

RESTORE AND REPAIR EXISTING STOREFRONT ON 827

CAST IRON CORNICE TO MATCH SECOND FLOOR CORNICE PROFILE

PIN MOUNTED METAL LETTER ON METAL SIGN BAND WITH COVE LIGHTING

NEW PAINTED WOOD STOREFRONT ON 831

BROADWAY - EXISTING AND PROPOSED ELEVATIONS

827-831 BROADWAY · RESTORATION WORK - APPROVED DESIGN_05.15.18



DXA studio

894 6th Avenue
5th Floor
NYC 10001
T 212 874 0567

dxastudio.com

SCALE As Noted
CLIENT
PROJECT NUMBER 17.32
DATE November 12 2020



827 STOREFRONT ALTERATED C.1981 EXISTING STOREFRONT 831 STOREFRONT ALTERED AFTER 827 AND AFTER 1981

SCRAPE, REPAINT AND REPAIR METAL BALCONIES AT 827, REATTACH LOOSE ELEMENTS AS REQUIRED, RESTORE MISSING PIECES TO MATCH EXISTING.

RESTORE AND REPAIR EXISTING STOREFRONT ON 827

EXISTING DOOR TO BE USED AS EGRESS



PROPOSED STOREFRONT

- UPLIGHTING ON EACH COLUMN (TYPICAL), FIXTURE COLOR TO MATCH FACADE
- CAST IRON CORNICE TO MATCH SECOND FLOOR CORNICE PROFILE
- PIN MOUNTED METAL LETTER ON METAL SIGN BAND WITH COVE LIGHTING AT BASE
- REPLICATE MISSING CAST IRON COLUMN TYP.
- NEW WOOD AND GLASS DOUBLE DOORS
- INTERACTIVE PLAQUE
- REPAIR AND REPAINT QUOINING IN HISTORIC COLOR
- NEW PAINTED WOOD STOREFRONT - TYPICAL

BROADWAY - EXISTING AND PROPOSED STOREFRONT ELEVATIONS
 827-831 BROADWAY · RENDERED STOREFRONT ELEVATIONS - APPROVED DESIGN_05.15.18

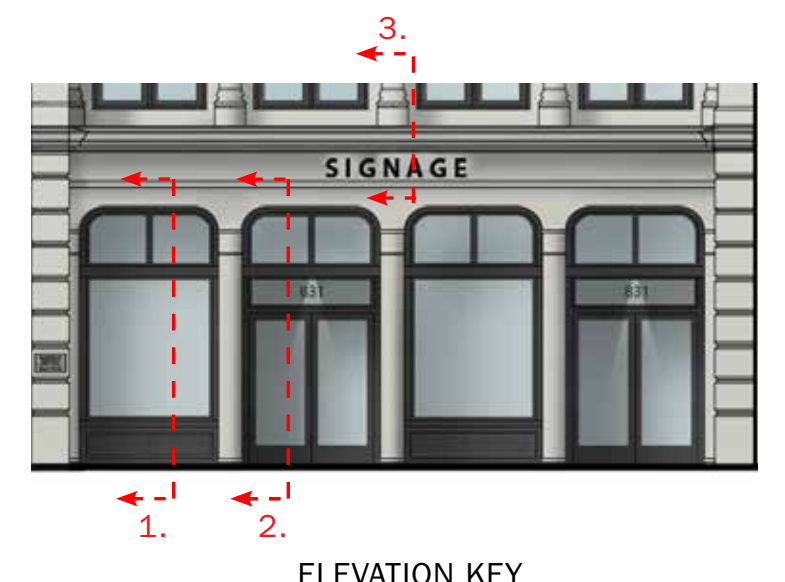
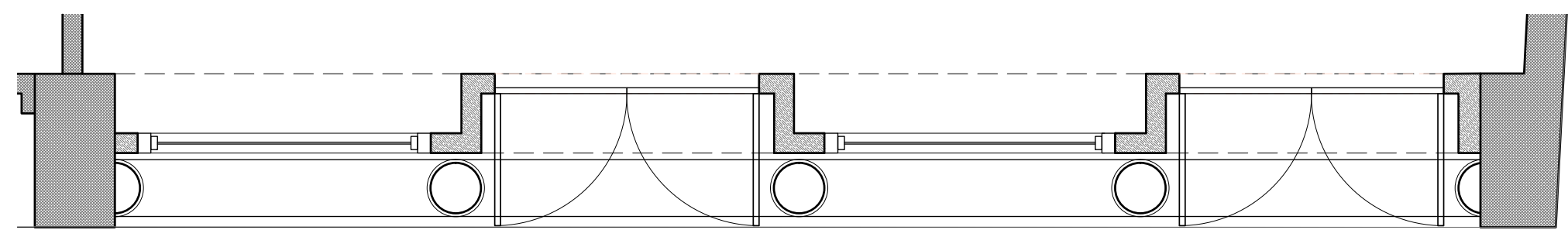
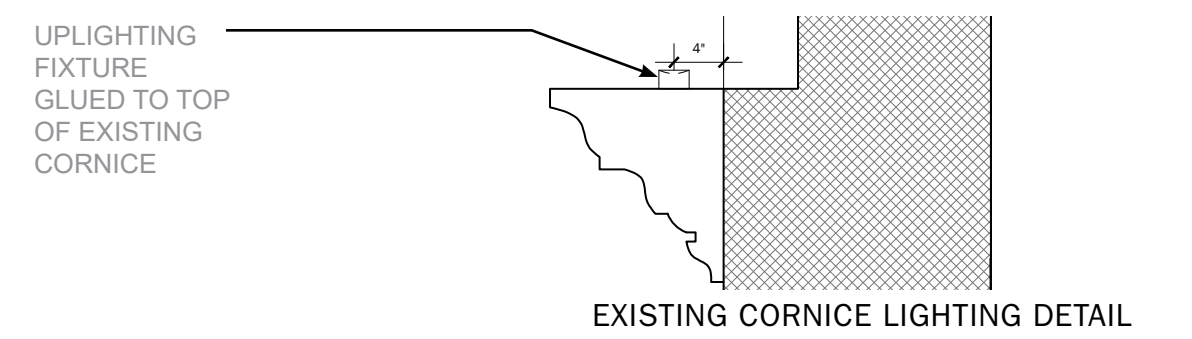
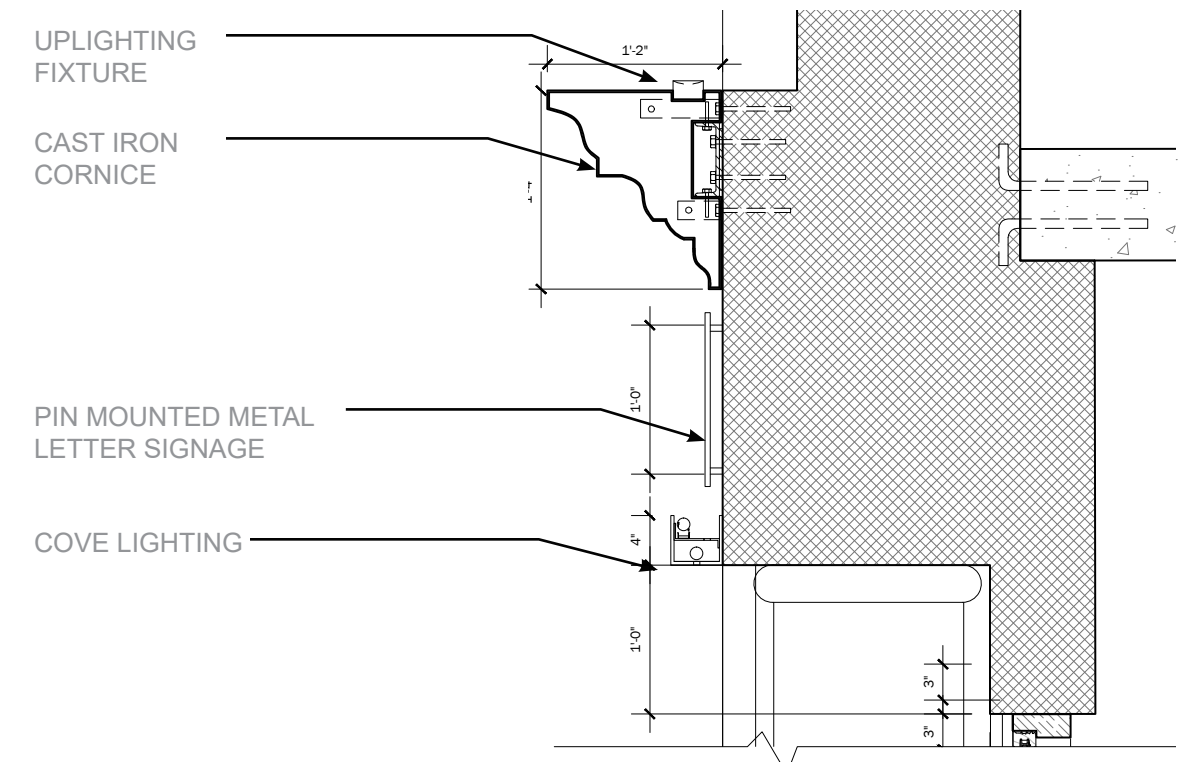
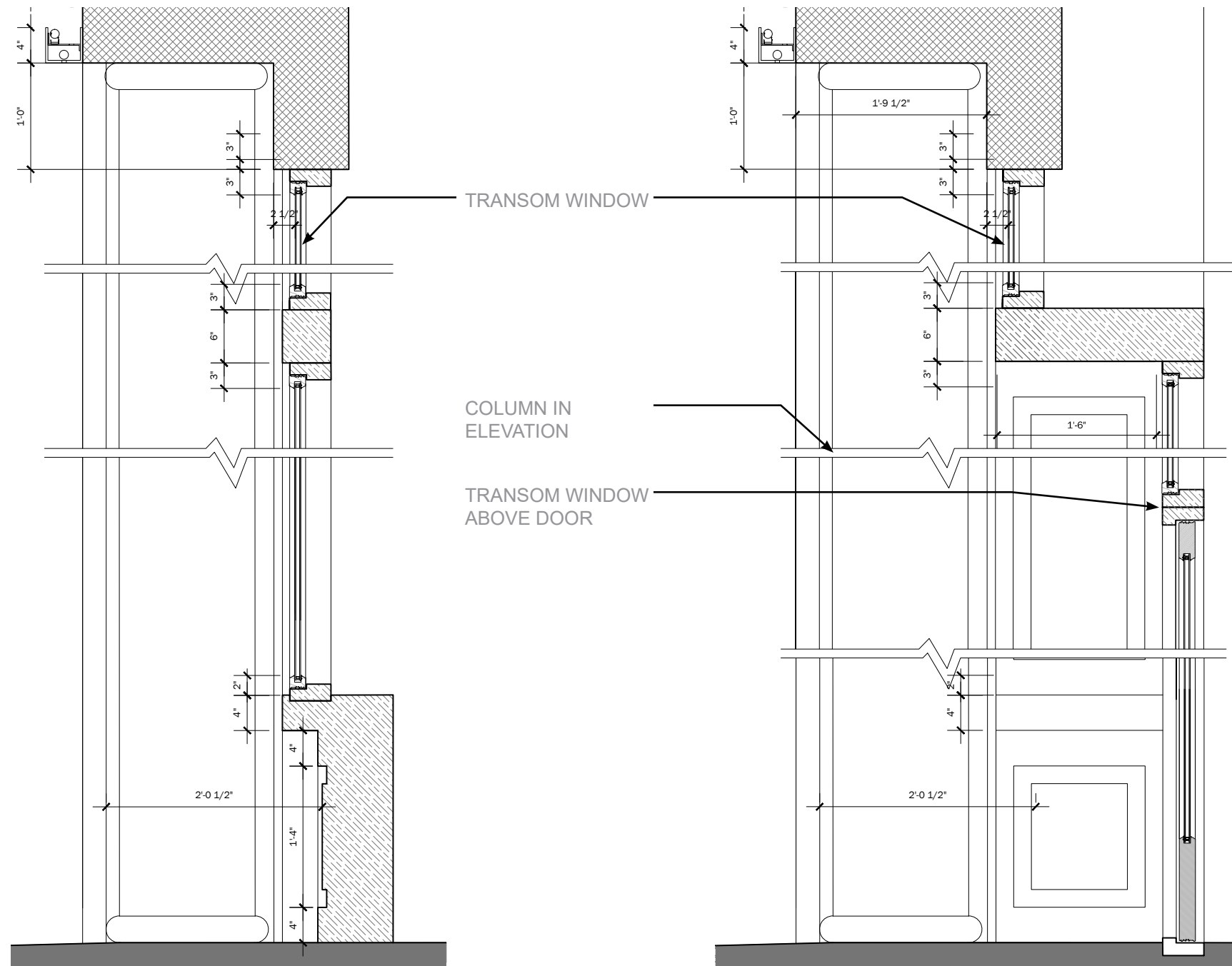

BROADWAY - 831 PROPOSED STOREFRONT SECTION DETAILS
 827-831 BROADWAY · STOREFRONT DETAILS - APPROVED DESIGN_05.15.18

APPENDIX

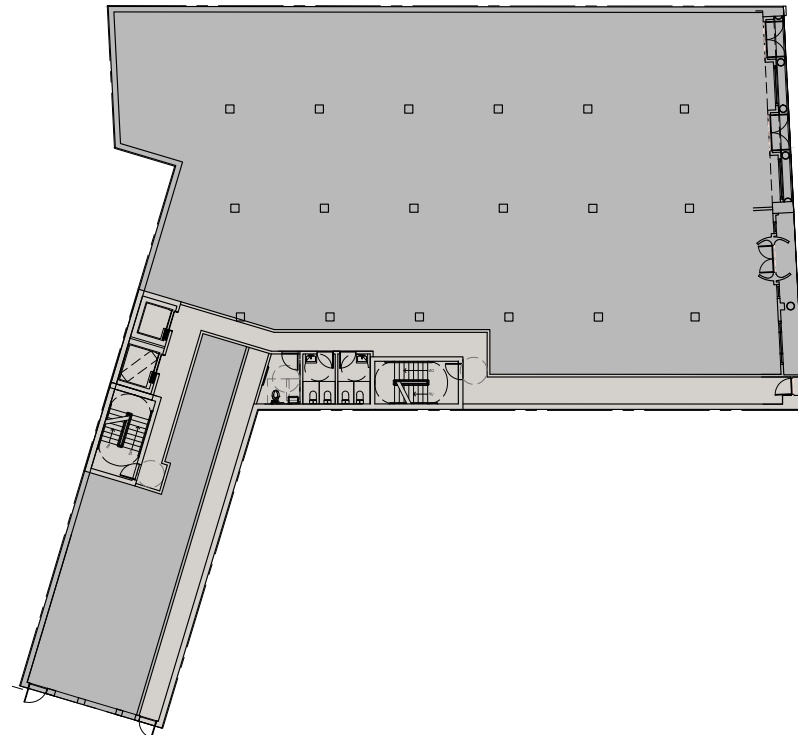

GROUND FLOOR PLAN

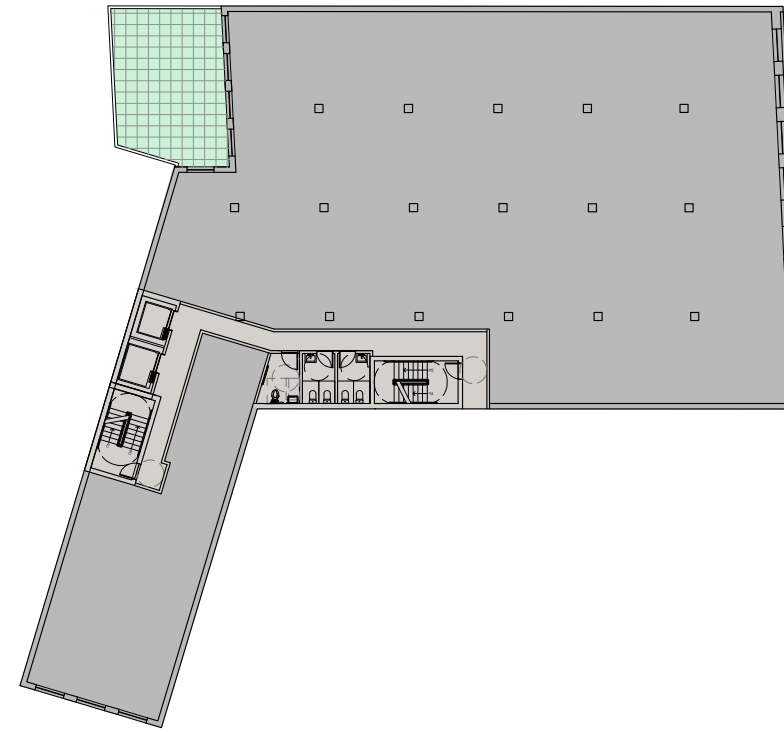

2ND - 4TH FLOOR PLANS

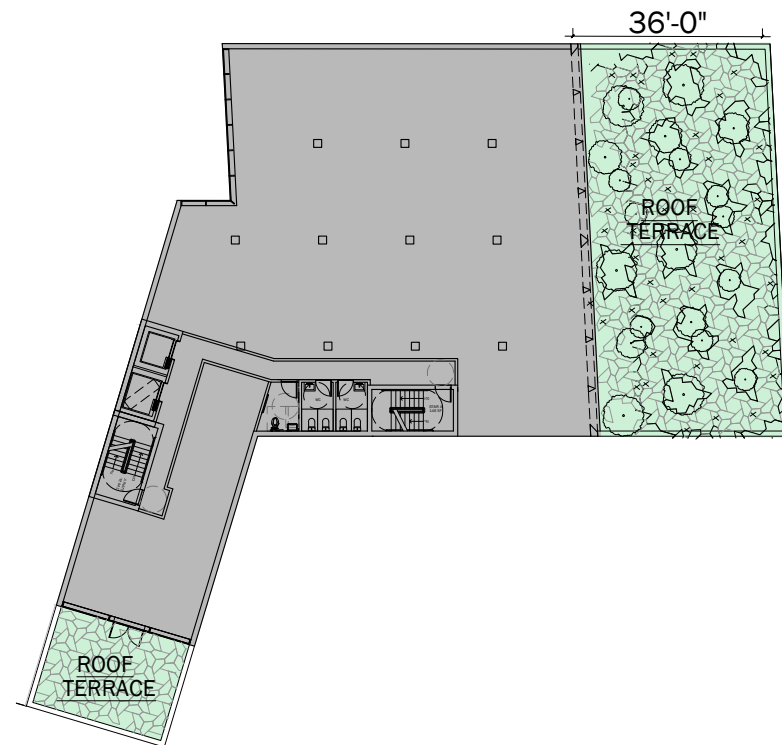

5TH - 7TH FLOOR PLANS

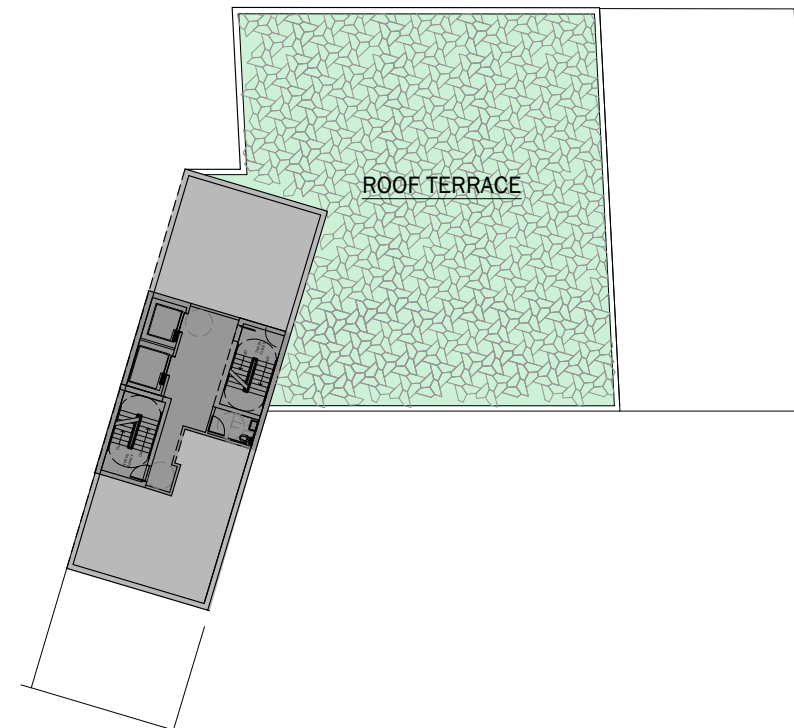

8TH - 11TH FLOOR PLANS



DXA studio

dxastudio.com

894 6th Avenue
5th Floor
NYC 10001
T 212 874 0567

827-831 BROADWAY - APPROVED DESIGN_05.15.18

SCALE	As Noted
CLIENT	
PROJECT NUMBER	17.32
DATE	November 12 2020

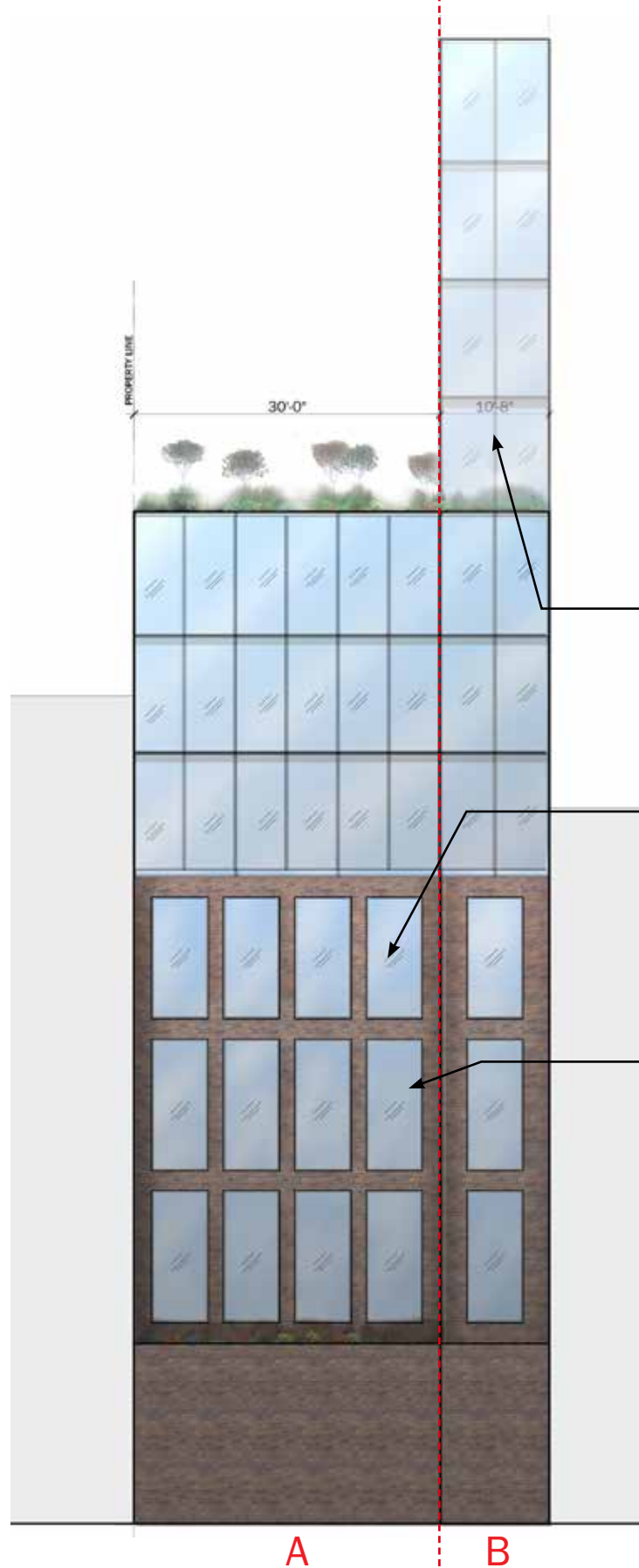

ELEVATOR AND STAIRS BULKHEAD

7 STORY ADDITION ON 12TH STREET

TERRACED ROOF GARDEN

FLAT METAL RAINSCREEN ON SOUTH, EAST AND NORTH FACADES

FLAT GLASS CURTAIN WALL ON UPPER FLOORS

TERRACED GARDENS ON FIFTH FLOOR SETBACKS

A B

1. REAR ELEVATIONS - UNFOLDED

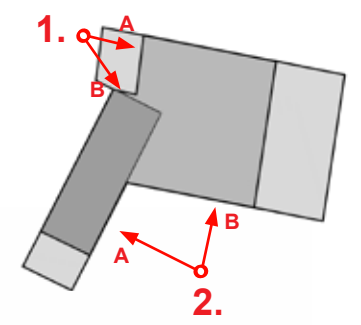

KEY PLAN

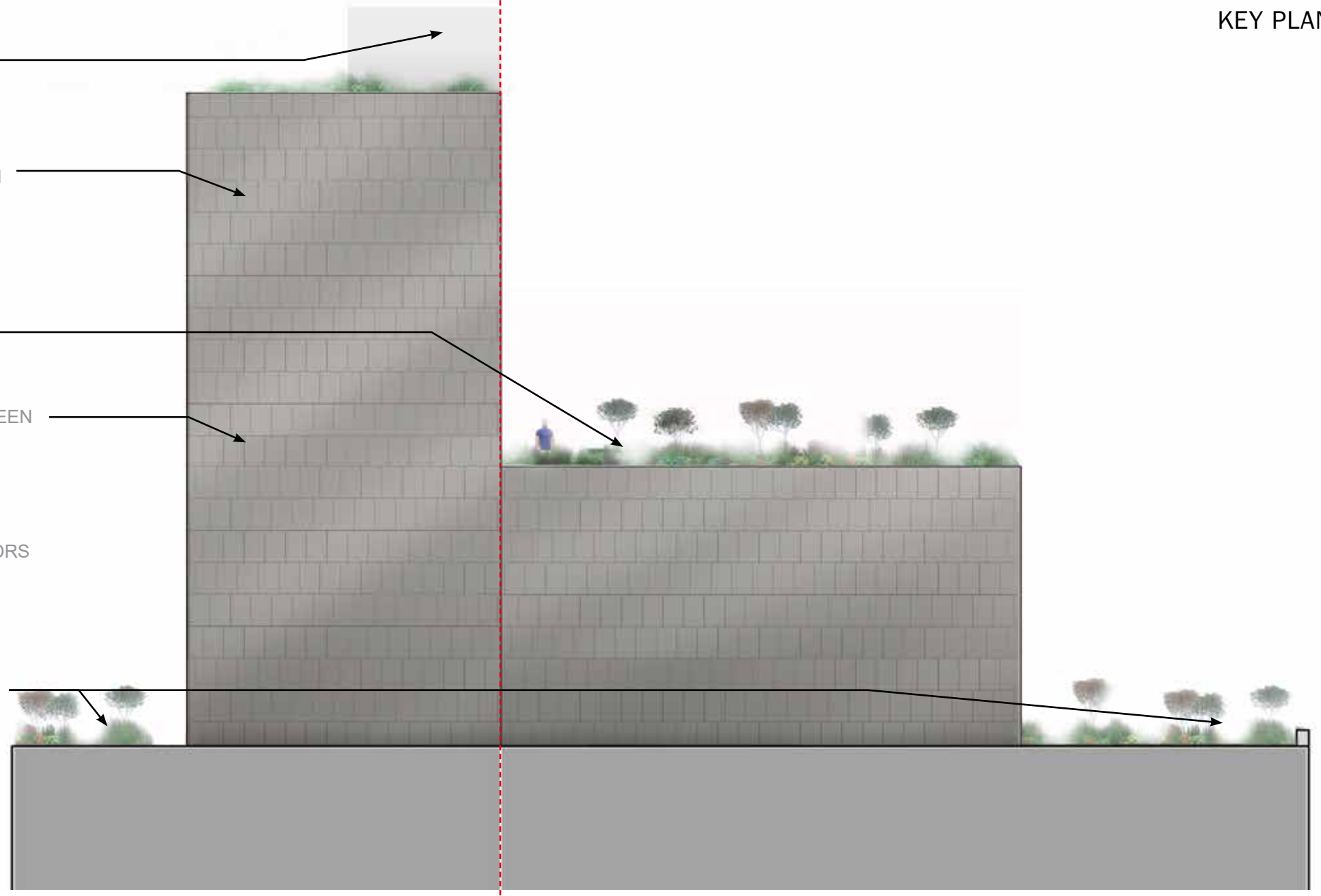

A

B

2. SOUTH SIDE ELEVATIONS - UNFOLDED

827-831 BROADWAY · PROPOSED ELEVATIONS - APPROVED DESIGN_05.15.18



DXA studio
894 6th Avenue
5th Floor
NYC 10001
T 212 874 0567
dxastudio.com

SCALE As Noted
CLIENT
PROJECT NUMBER 17.32
DATE November 12 2020

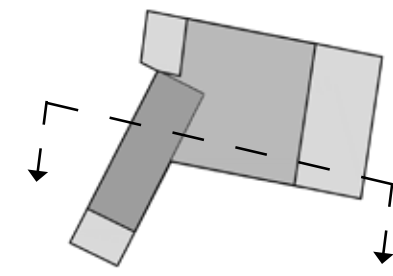
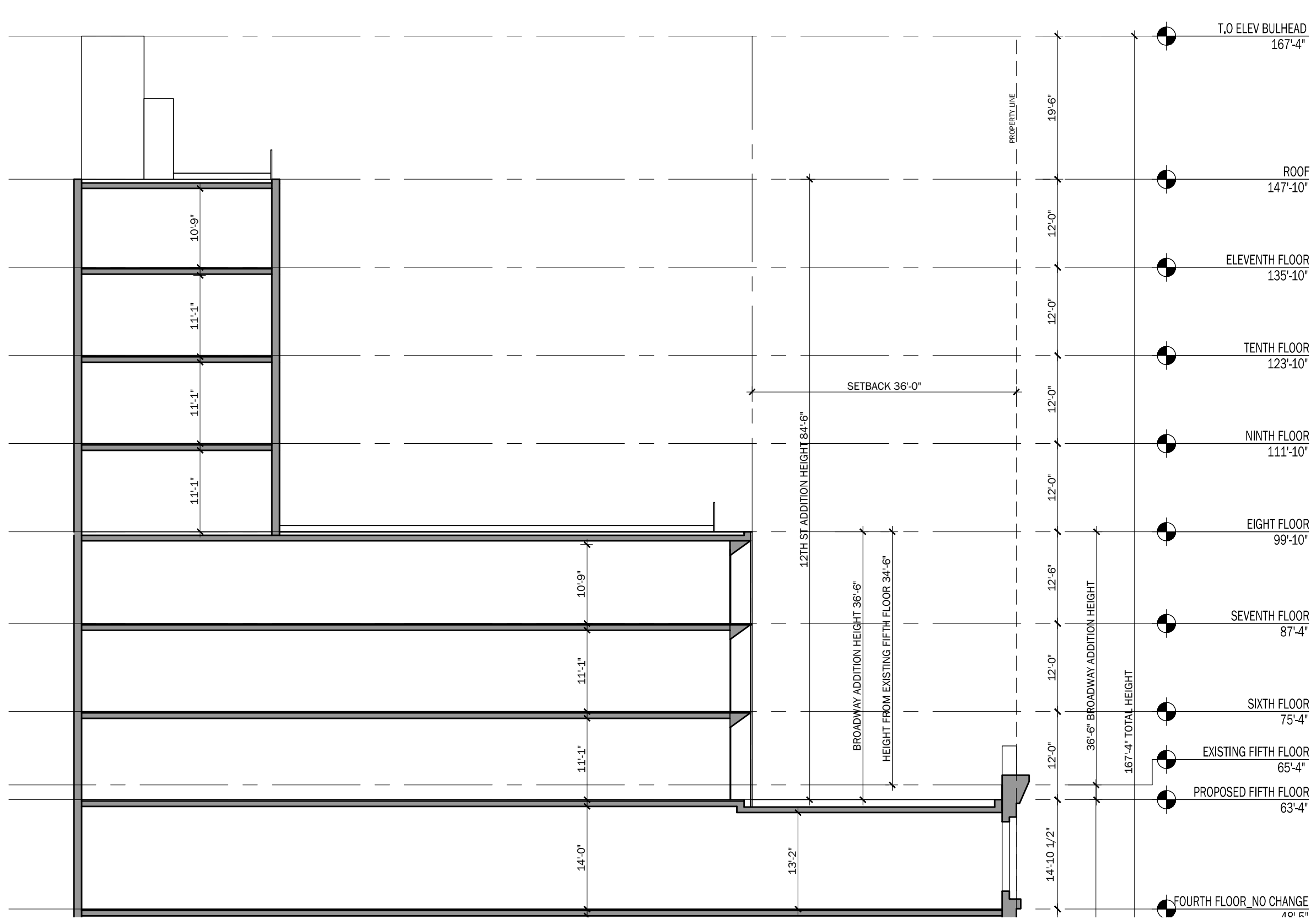

827-831 BROADWAY · MASSING SECTION THROUGH ADDITION - APPROVED DESIGN_05.15.18



DXA studio
 894 6th Avenue
 5th Floor
 NYC 10001
 T 212 874 0567
 dxastudio.com

SCALE As Noted
CLIENT
PROJECT NUMBER 17.32
DATE November 12 2020

40

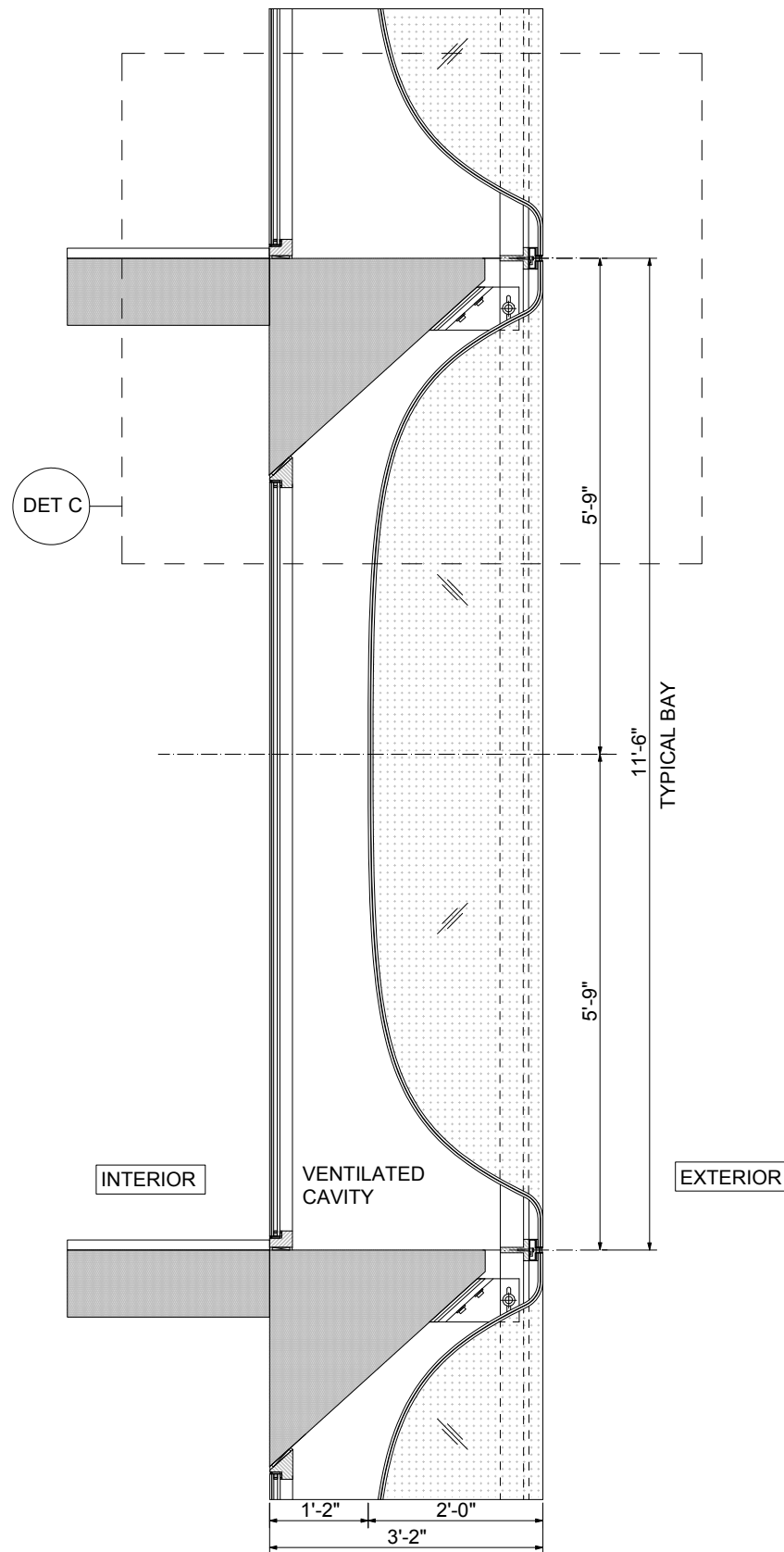

SECTION - TYPICAL BAY - DOUBLE SKIN FACADE

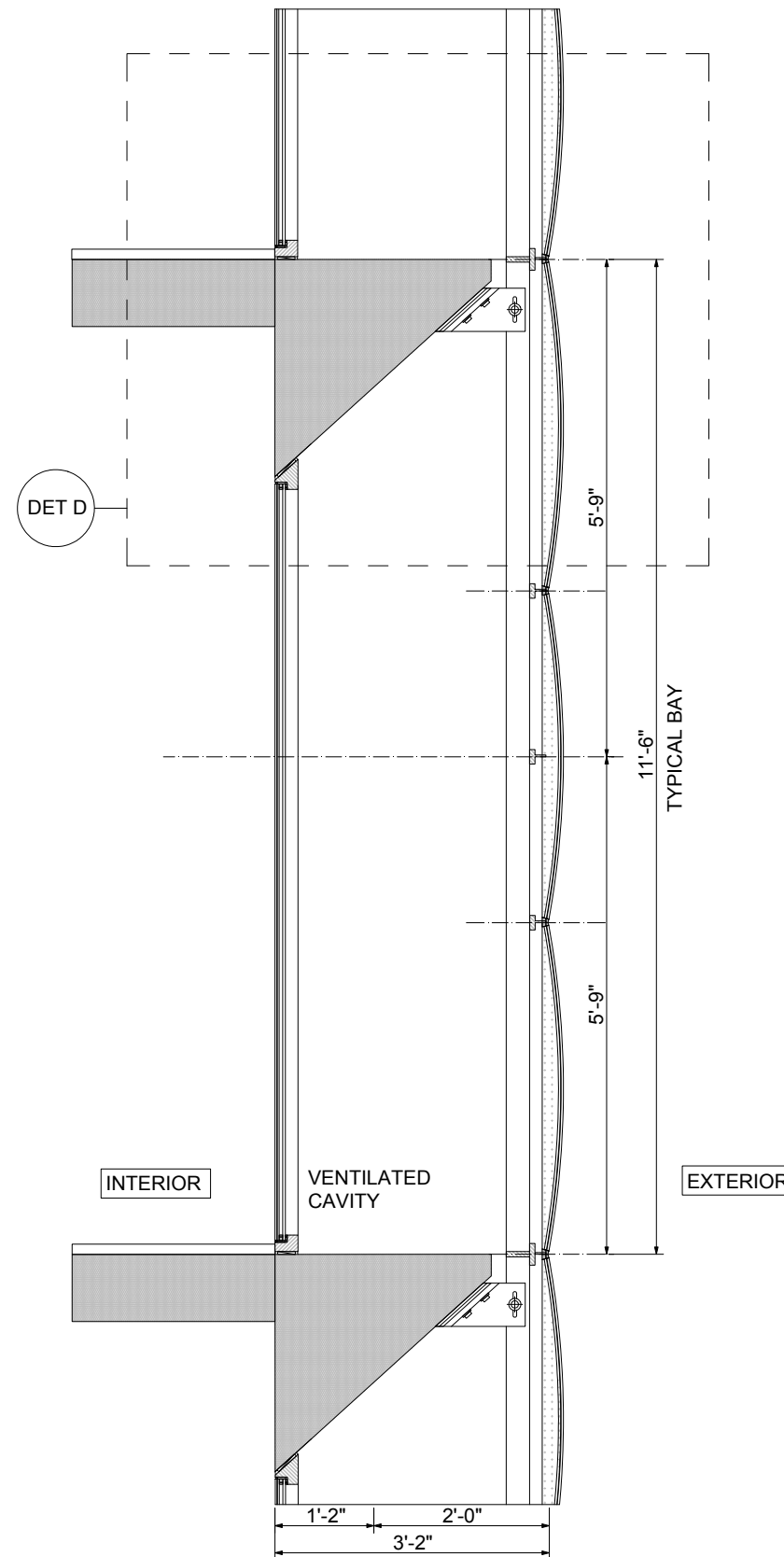

SECTION - QUOIN - DOUBLE SKIN FACADE

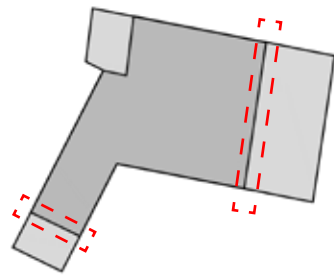
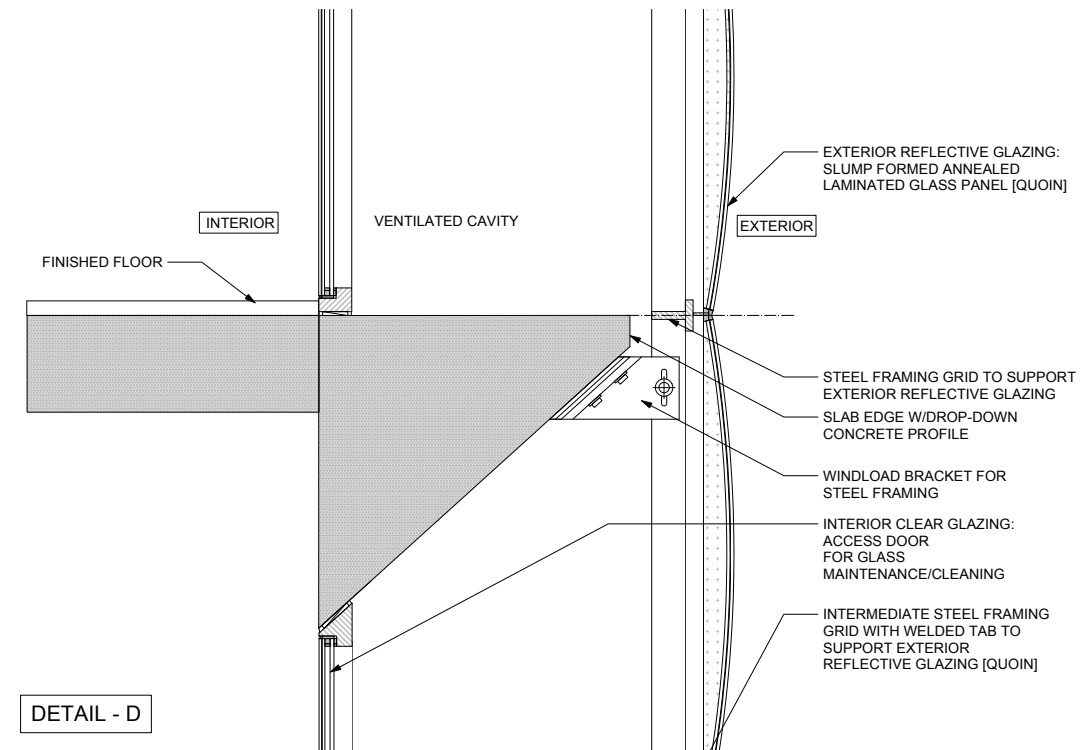
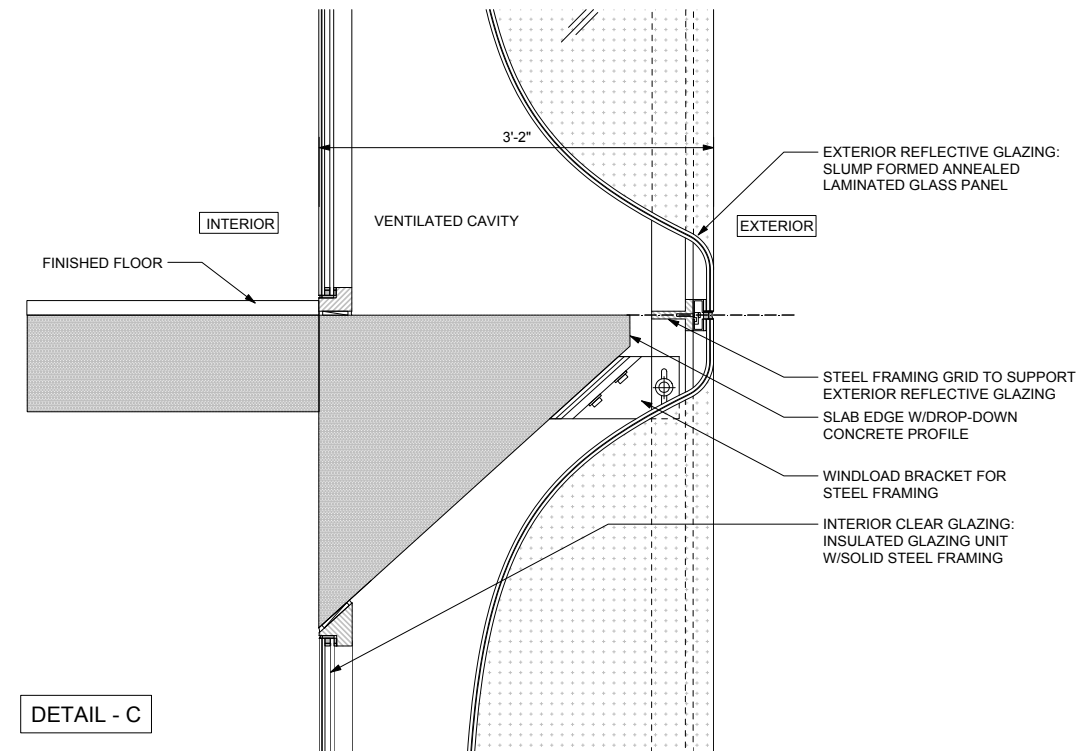

KEY PLAN



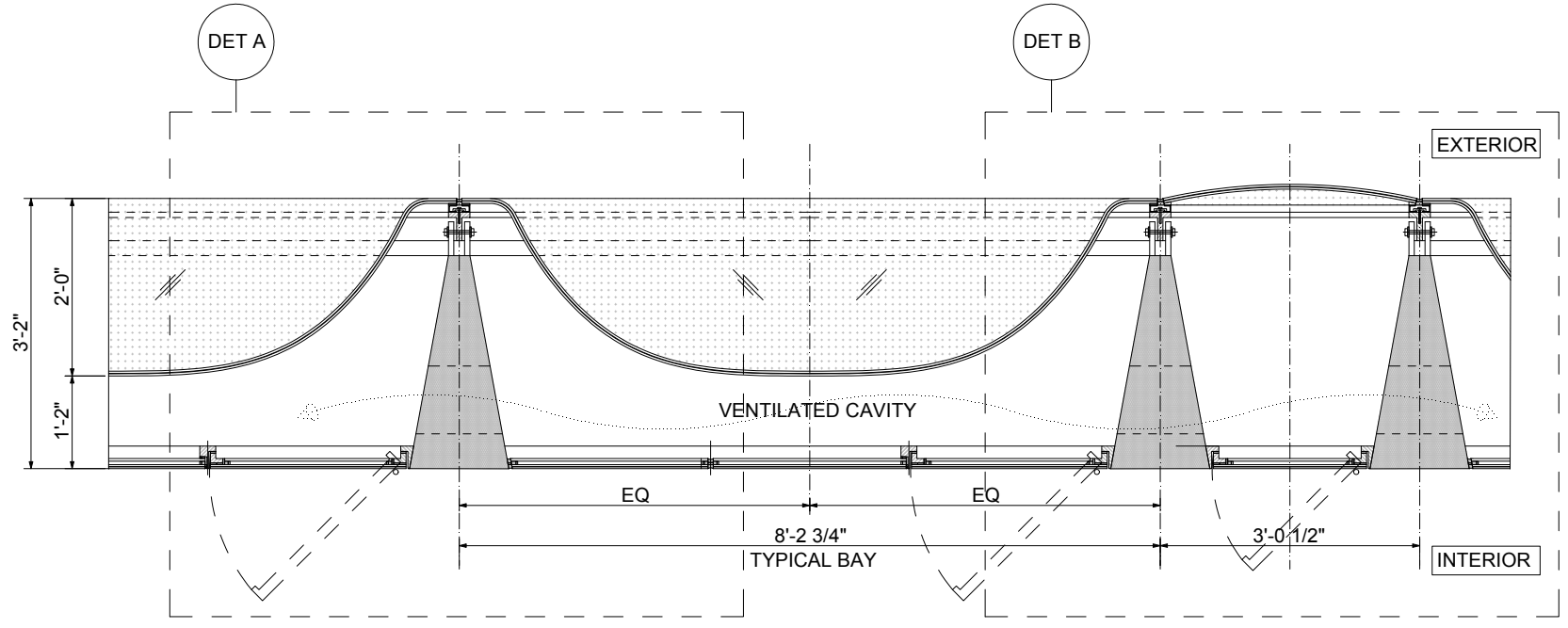

PLAN - TYPICAL BAY - DOUBLE SKIN FACADE

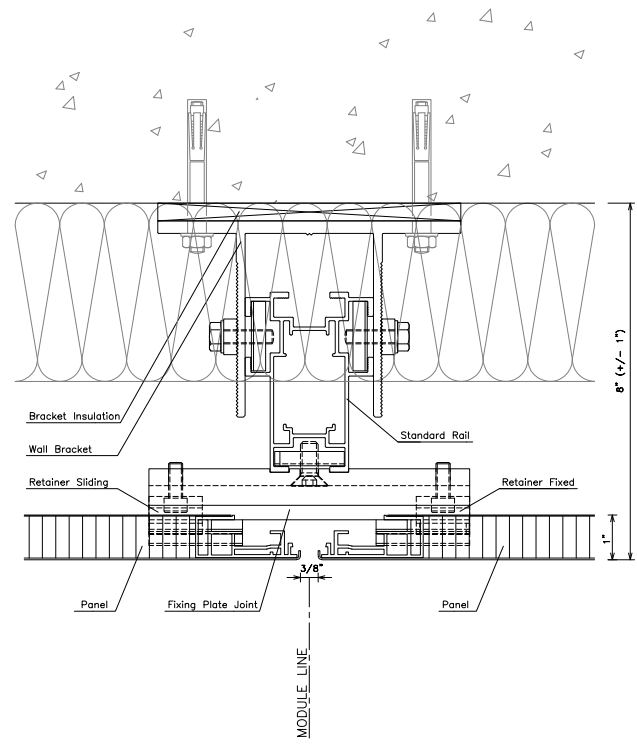

PLAN - METAL RAINSCREEN PANEL - TYPICAL VERT. JT.

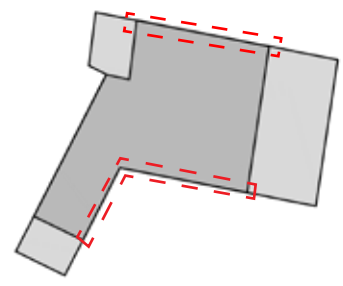

KEY PLAN

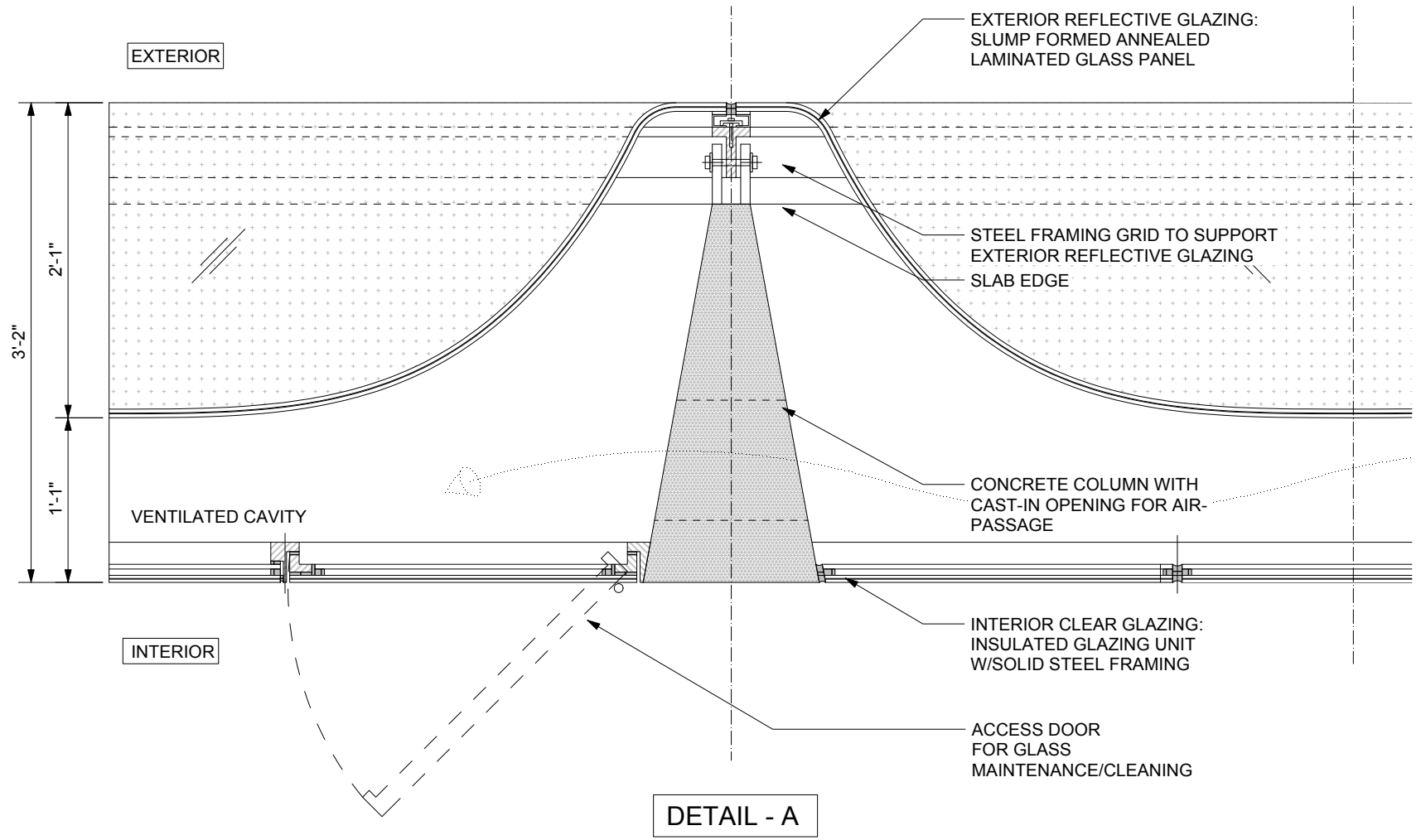

DETAIL - A

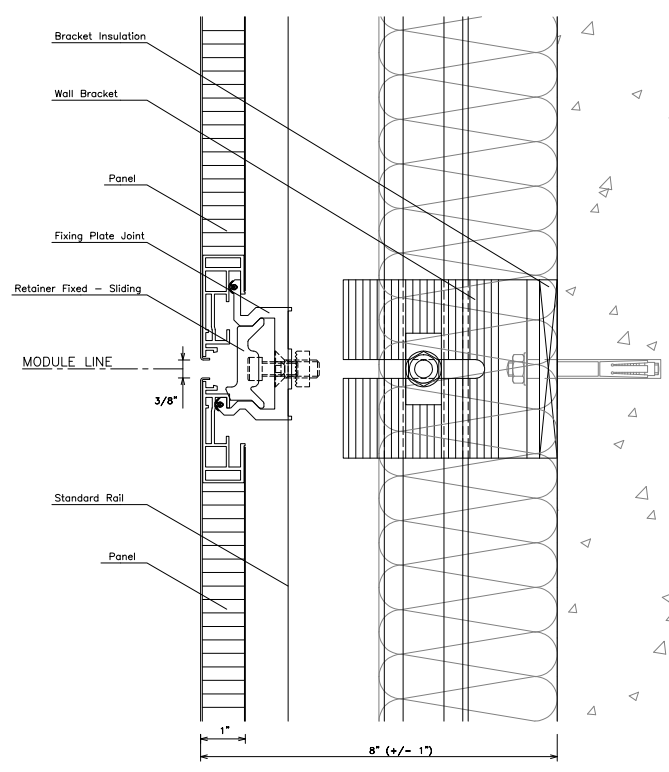

SECTION - METAL RAINSCREEN PANEL - TYPICAL HOR. JT.

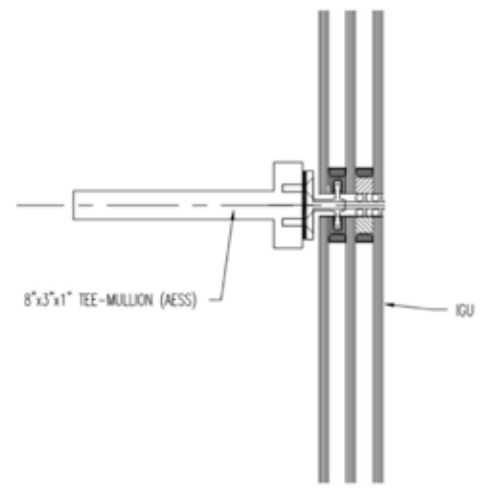

T MULLION DETAIL FOR CURTAIN WALL SYSTEM